

# EVS

**EVS**

## WŁAŚCIWOŚCI / FEATURES

Seria wielostopniowych pomp odśrodkowych o wydajności do 80 m<sup>3</sup>/h i wysokości podnoszenia do 230 m, połączone z silnikiem elektrycznym za pomocą sztywnego złącza, nadające się do czystej wody. Wszystkie elementy hydrauliczne stykające się z pompowaną cieczą są wykonane ze stali nierdzewnej AISI 304. Pompy są stosowane w zestawach podnoszenia ciśnienia, jako pompy nawadniające oraz w myjniach wysokociśnieniowych.

*It's a series of centrifugal multistage pumps delivery up to 80 m<sup>3</sup>/h and head up to 230 m, coupled to the electric motor by rigid joint, suitable for clean water. All the hydraulics components in contact with the pumped liquid are made of stainless steel AISI 304. Used in civil application to boost pressure, irrigation and high pressure washing plants.*

## MATERIAŁY / MATERIALS

- Korpus ssący i obudowa tłoczna: stal nierdzewna AISI 304
- Wirnik wykonany ze stali nierdzewnej AISI 304
- Płaszcz zewnętrzny wykonany ze stali nierdzewnej AISI 304
- Pokrywa górna i pokrywa dolna: stal nierdzewna AISI 304
- Wał pompy wykonany ze stali nierdzewnej AISI 304
- Uszczelnienie mechaniczne: grafit / silikon
  
- *Suction casing and Delivery casing: Stainless steel AISI 304*
- *Impeller: Stainless Steel AISI 304*
- *External Jackets: Stainless Steel AISI 304*
- *Upper cover and Lower cover: Stainless Steel AISI 304*
- *Pump shaft: Stainless Steel AISI 304*
- *Mechanical seal: Graphite / Silicon*

## SILNIK / MOTOR

- 2-biegunowy indukcyjny silnik elektryczny
- Stopień ochrony: IP55
- Izolacja klasy F
- Zasilanie jednofazowe: 230V-50Hz; Zasilanie trójfazowe: 230 / 400V-50Hz
  
- *Two poles induction motor*
- *Protection: IP55*
- *Insulation class F*
- *Single phase: 230V-50 Hz; Three-phase: 230/400V-50 Hz*

## WARUNKI DZIAŁANIA / OPERATING CONDITIONS

- Temperatura pompowanej cieczy: od 0° do 110 °C (temperatura maksymalna do użytku domowego EN60335-2-41 to 35°C)
- Maksymalna temperatura pracy w otoczeniu do 40°C
- Maksymalne ciśnienie robocze: 25 bar
  
- *Temperature of liquid from 0° to 110°C (35°C max for domestic use-EN60335-2-41)*
- *Ambient temperature max to 40°C*
- *Maximum working pressure: 25 bar*

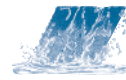

PIONOWE, WIELOSTOPNIOWE POMPY ELEKTRYCZNE ZE STALI NIERDZEWNEJ  
**VERTICAL MULTISTAGE STAINLESS STEEL ELECTRIC PUMPS**

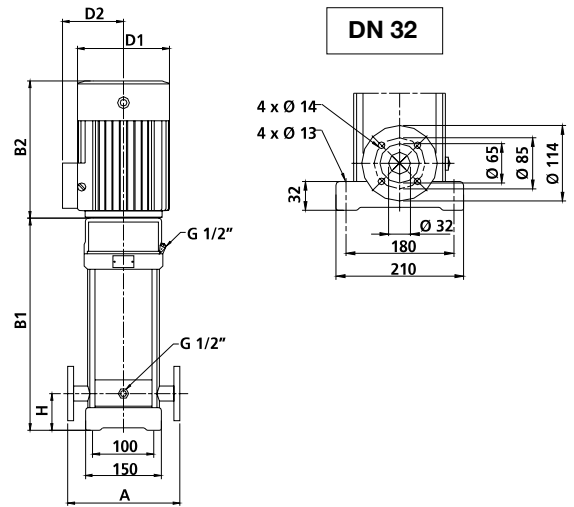
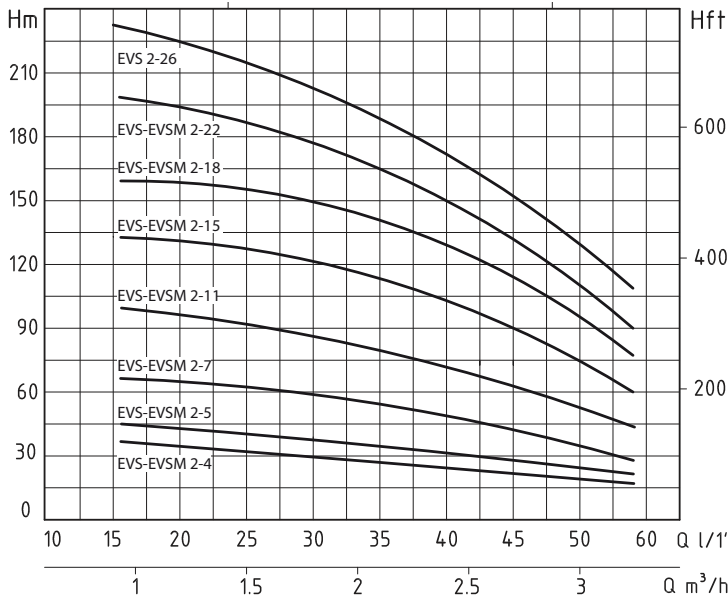

**DANE TECHNICZNE PRZY 2900 OBR./MIN. / TECHNICAL PERFORMANCE AT 2900 RPM**

Model <i>Model</i>		P2		A		Q (m <sup>3</sup> /h - l/min)							
1~	3~	HP	KW	1x230V	3x400V	1	1,2	1,6	2	2,4	2,8	3,2	3,5
						16	20	26	33	40	46	53	58
Całkowita wysokość podnoszenia w m słupa wody <i>Total head in meters w.c.</i>													
EVSM 2-4	EVS 2-4	0,75	0,55	4	4	36	35	33	30	26	24	20	16
EVSM 2-5	EVS 2-5	0,75	0,55	4	4	45	43	40	37	33	30	24	20
EVSM 2-7	EVS 2-7	1	0,75	5	1,7	63	61	57	52	47	41	35	28
EVSM 2-11	EVS 2-11	1,5	1,1	6,9	2,7	98	95	89	82	73	64	54	44
EVSM 2-15	EVS 2-15	2	1,5	7	3,5	134	130	123	112	100	90	73	60
EVSM 2-18	EVS 2-18	3	2,2	13,5	4,7	161	157	148	136	121	108	91	76
EVSM 2-22	EVS 2-22	3	2,2	13,5	4,7	197	192	180	165	148	130	110	90
	EVS 2-26	4	3		6,1	232	228	214	198	179	158	130	110

MODEL POMPY <i>PUMP'S MODEL</i>		WYMIARY POMP mm <i>PUMP'S DIMENSIONS mm</i>							WYMIARY OPAKOWANIA mm <i>PACKING DIMENSIONS mm</i>			WAGA <i>WEIGHT</i>		
Jednofazowa <i>Single-phase</i>	Trójfazowa <i>Three-phase</i>	A	H	B1	B2	B1 + B2	D1	D2	Kołnierz <i>Flanges</i>	P	L	H	kg	
EVSM 2-4	EVS 2-4	250	75	294	210	504	148	117		DN 32	320	765	395	34
EVSM 2-5	EVS 2-5	250	75	312	210	522	148	117			320	765	395	34,1
EVSM 2-7	EVS 2-7	250	75	358	245	603	170	142			320	765	395	38,1
EVSM 2-11	EVS 2-11	250	75	430	245	675	170	142			320	765	395	42,1
EVSM 2-15	EVS 2-15	250	75	512	290	802	190	155			372	965	445	50,9
EVSM 2-18	EVS 2-18	250	75	566	290	856	190	155			372	965	445	55
EVSM 2-22	EVS 2-22	250	75	638	290	928	190	155			365	1115	440	59,4
	EVS 2-26	250	75	720	315	1035	197	165			365	1115	440	66,1

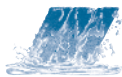

# EVS

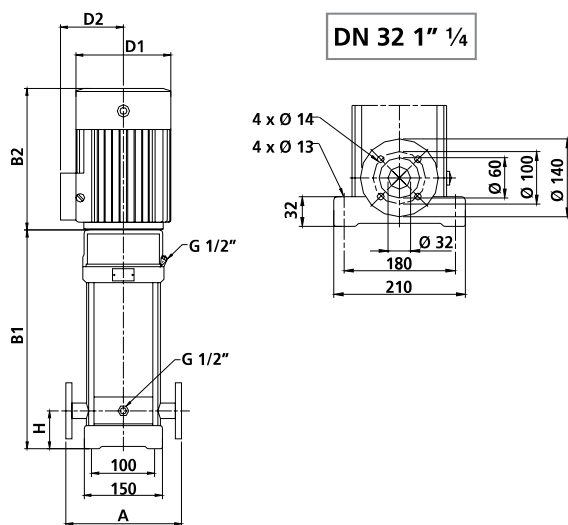
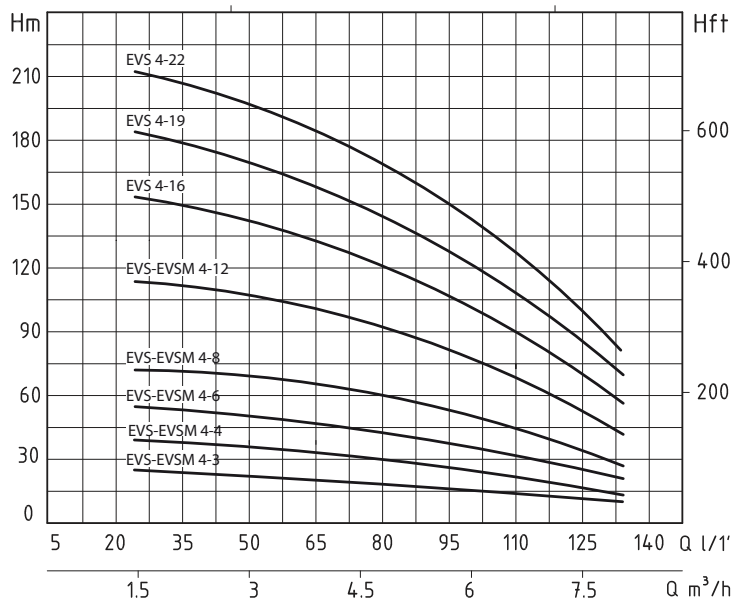

**DANE TECHNICZNE PRZY 2900 OBR./MIN. / TECHNICAL PERFORMANCE AT 2900 RPM**

Model <i>Model</i>		P2		A		Q (m³/h - l/min)							
1~	3~	HP	kW	1x230V	3x400V	1,5	2	3	4	5	6	7	8
						25	33	50	66	83	100	116	133
Całkowita wysokość podnoszenia w m słupa wody <i>Total head in meters w.c.</i>													
EVS 4-3	EVS 4-3	0,75	0,55	4	1,4	28	27	26	24	20	18	13	10
EVS 4-4	EVS 4-4	1	0,75	5	1,7	38	36	34	32	27	24	19	13
EVS 4-6	EVS 4-6	1,5	1,1	6,9	2,5	56	54	52	48	41	37	28	20
EVS 4-8	EVS 4-8	2	1,5	9,7	3,5	74	72	70	64	55	50	38	27
EVS 4-12	EVS 4-12	3	2,2	13,5	4,7	114	108	104	95	85	75	58	41
	EVS 4-16	4	3		6,1	152	144	140	129	115	101	78	55
	EVS 4-19	5,5	4		8	183	171	168	153	137	122	93	67
	EVS 4-22	5,5	4		8	211	200	192	178	160	138	108	79

MODEL POMPY <i>PUMP'S MODEL</i>		WYMIARY POMP mm <i>PUMP'S DIMENSIONS mm</i>								WYMIARY OPAKOWANIA mm <i>PACKING DIMENSIONS mm</i>			WAGA <i>WEIGHT</i>
Jednofazowa <i>Single-phase</i>	Trójfazowa <i>Three-phase</i>	A	H	B1	B2	B1 + B2	D1	D2	Kołnierz <i>Flanges</i>	P	L	H	kg
EVS 4-3	EVS 4-3	250	75	303	210	513	148	148	DN 32 1" 1/4	320	765	395	37,1
EVS 4-4	EVS 4-4	250	75	340	245	585	170	142	DN 32 1" 1/4	320	765	395	39
EVS 4-6	EVS 4-6	250	75	394	245	639	170	142	DN 32 1" 1/4	320	765	395	44,1
EVS 4-8	EVS 4-8	250	75	458	290	748	190	155	DN 32 1" 1/4	372	965	445	52,1
EVS 4-12	EVS 4-12	250	75	566	290	856	190	155	DN 32 1" 1/4	372	965	445	57,1
	EVS 4-16	250	75	684	315	999	197	165	DN 32 1" 1/4	365	1115	440	64,1
	EVS 4-19	250	75	765	335	1100	230	188	DN 32 1" 1/4	417	1215	445	78,5
	EVS 4-22	250	75	846	335	1181	230	188	DN 32 1" 1/4	417	1215	445	81,8

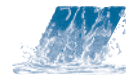

PIONOWE, WIELOSTOPNIOWE POMPY ELEKTRYCZNE ZE STALI NIERDZEWNEJ  
**VERTICAL MULTISTAGE STAINLESS STEEL ELECTRIC PUMPS**

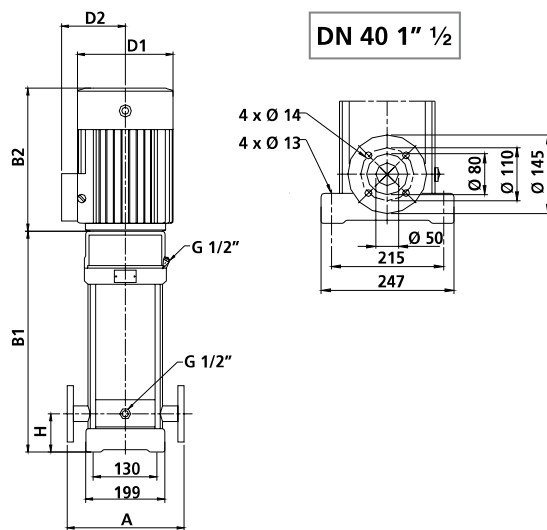
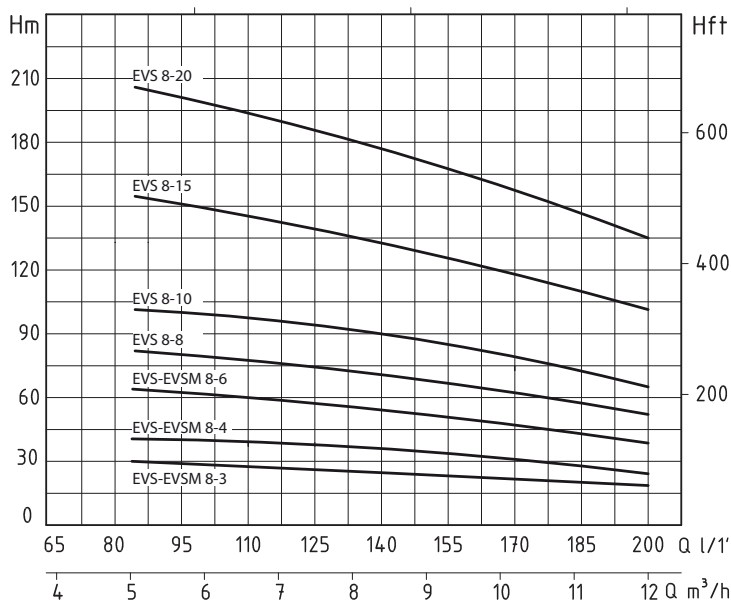

**DANE TECHNICZNE PRZY 2900 OBR./MIN. / TECHNICAL PERFORMANCE AT 2900 RPM**

Model <i>Model</i>		P2		A		Q (m³/h - l/min)							
1~	3~	HP	kW	1x230V	3x400V	5	6	7	8	9	10	11	12
						83	100	116	133	150	166	183	200
Całkowita wysokość podnoszenia w m słupa wody <i>Total head in meters w.c.</i>													
EVS 8-3	EVS 8-3	1,5	1,1	6,9	2,5	30	29,5	28,5	27	25	24	21	19
EVS 8-4	EVS 8-4	2	1,5	9,7	3,5	41	39,5	38	36	34	32	28	26
EVS 8-6	EVS 8-6	3	2,2	13,5	4,7	62	60	57	54	51	48	43	39
	EVS 8-8	4	3		6,1	83	80	77	73	69	65	58	52
	EVS 8-10	5,5	4		8	104	100	97	92	87	81	73	65
	EVS 8-15	7,5	5,5		10	155	151	146	139	130	121	110	99
	EVS 8-20	10	7,5		14,5	208	200	190	180	170	163	150	135

MODEL POMPY <i>PUMP'S MODEL</i>		WYMIARY POMPY mm <i>PUMP'S DIMENSIONS mm</i>								WYMIARY OPAKOWANIA mm <i>PACKING DIMENSIONS mm</i>			WAGA <i>WEIGHT</i>
Jednofazowa <i>Single-phase</i>	Trójfazowa <i>Three-phase</i>	A	H	B1	B2	B1 + B2	D1	D2	Kołnierz <i>Flanges</i>	P	L	H	kg
EVS 8-3	EVS 8-3	280	80	377	245	622	170	142	DN 40 1" 1/2	320	765	395	51,8
EVS 8-4	EVS 8-4	280	80	417	290	707	190	155	DN 40 1" 1/2	372	965	445	62
EVS 8-6	EVS 8-6	280	80	477	290	767	190	155	DN 40 1" 1/2	372	965	445	63
	EVS 8-8	280	80	547	315	862	197	165	DN 40 1" 1/2	372	965	445	67,6
	EVS 8-10	280	80	607	335	942	230	188	DN 40 1" 1/2	365	1115	440	82,8
	EVS 8-15	280	80	807	430	1237	260	208	DN 40 1" 1/2	417	1215	445	104,7
	EVS 8-20	280	80	927	430	1357	260	208	DN 40 1" 1/2	515	1515	493	125,1

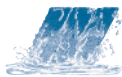

# EVS

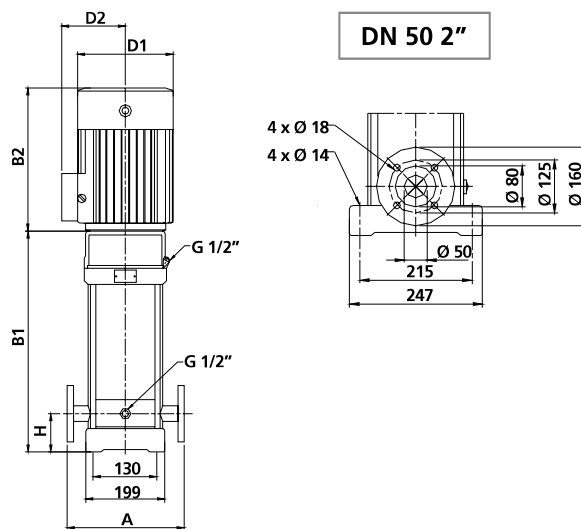
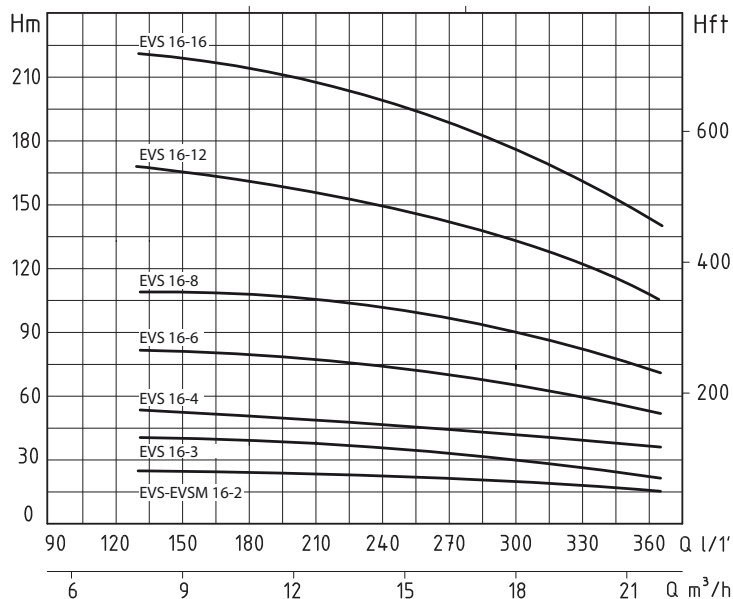

**DANE TECHNICZNE PRZY 2900 OBR./MIN. / TECHNICAL PERFORMANCE AT 2900 RPM**

Model <i>Model</i>		P2		A		Q (m <sup>3</sup> /h - l/min)							
1~	3~	HP	kW	1x230V	3x400V	8	10	12	14	16	18	20	22
						133	166	200	233	266	300	333	366
Całkowita wysokość podnoszenia w m stupa wody <i>Total head in meters w.c.</i>													
EVSM 16-2	EVS 16-2	3	2,2	13,5	4,7	27	26	25	24	22	21	19	16
	EVS 16-3	4	3		6,1	41	40	38	37	34	32	26	25
	EVS 16-4	5,5	4		8	54	53	52	49	46	43	38	34
	EVS 16-6	7,5	5,5		10,7	82	80	78	74	70	64	58	52
	EVS 16-8	10	7,5		14,5	110	108	104	99	94	86	77	70
	EVS 16-12	15	11		19,4	166	162	157	150	141	130	116	105
	EVS 16-16	20	15		26	222	217	210	200	189	174	156	140

MODEL POMPY <i>PUMP'S MODEL</i>		WYMIARY POMP mm <i>PUMP'S DIMENSIONS mm</i>								WYMIARY OPAKOWANIA mm <i>PACKING DIMENSIONS mm</i>			WAGA <i>WEIGHT</i>
Jednofazowa <i>Single-phase</i>	Trójfazowa <i>Three-phase</i>	A	H	B1	B2	B1 + B2	D1	D2	Kołnierz <i>Flanges</i>	P	L	H	kg
EVSM 16-2	EVS 16-2	300	90	397	290	687	190	155	DN 50 2"	365	1115	440	63,5
	EVS 16-3	300	90	452	315	767	197	165	DN 50 2"	372	965	445	69,5
	EVS 16-4	300	90	497	335	832	230	188	DN 50 2"	372	965	445	78,2
	EVS 16-6	300	90	607	430	1037	260	208	DN 50 2"	365	1115	440	99,1
	EVS 16-8	300	90	697	430	1127	260	208	DN 50 2"	417	1215	445	109,6
	EVS 16-12	300	90	965	490	1455	330	255	DN 50 2"	515	1515	493	196,5
	EVS 16-16	300	90	1145	490	1635	330	255	DN 50 2"	515	1715	490	214,5

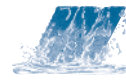

PIONOWE, WIELOSTOPNIOWE POMPY ELEKTRYCZNE ZE STALI NIERDZEWNEJ  
**VERTICAL MULTISTAGE STAINLESS STEEL ELECTRIC PUMPS**

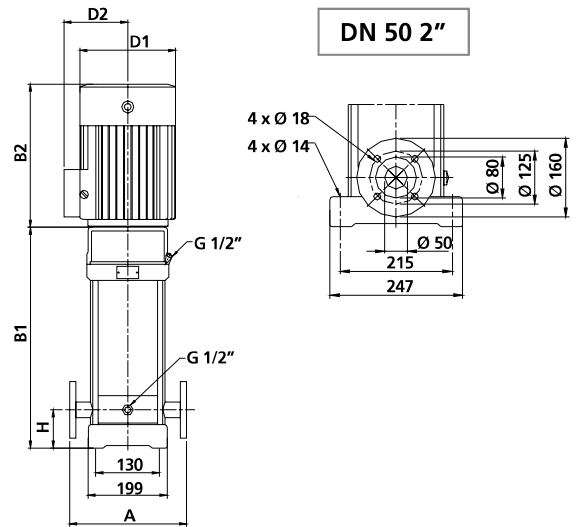
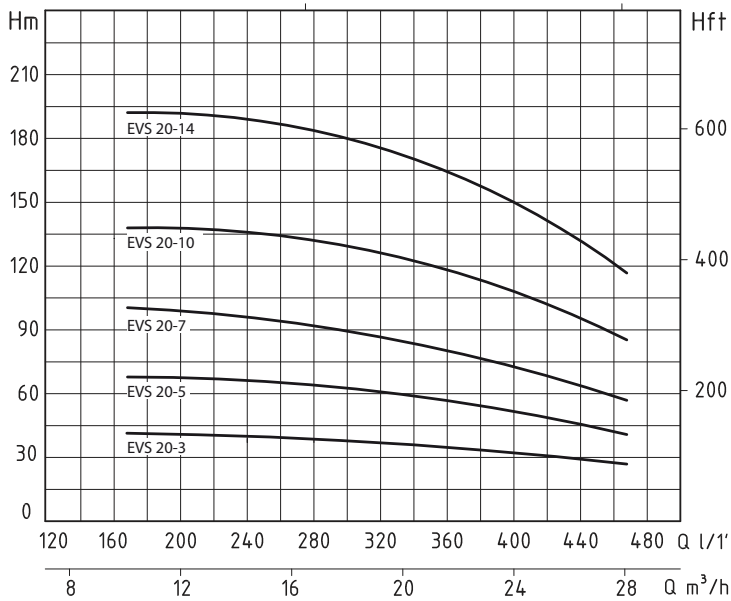

**DANE TECHNICZNE PRZY 2900 OBR./MIN. / TECHNICAL PERFORMANCE AT 2900 RPM**

Model <i>Model</i>	P2		A	Q (m <sup>3</sup> /h - l/min)								
				10	12	14	16	20	22	24	26	28
3~	HP	kW	3x400V	166	200	233	266	333	366	400	433	466
				Całkowita wysokość podnoszenia w m słupa wody <i>Total head in meters w.c.</i>								
EVS 20-3	5,5	4	8	41	40	39	38	35	33	30	27	24
EVS 20-5	7,5	5,5	10,7	67	66	64	62	58	55	50	45	40
EVS 20-7	10	7,5	14,5	95	93	91	89	82	77	71	65	58
EVS 20-10	15	11	19,4	136	134	131	128	118	111	103	95	85
EVS 20-14	20	15	29	192	189	185	180	166	156	145	133	119

MODEL POMPY <i>PUMP'S MODEL</i>	WYMIARY POMPY mm <i>PUMP'S DIMENSIONS mm</i>								WYMIARY OPAKOWANIA mm <i>PACKING DIMENSIONS mm</i>			WAGA <i>WEIGHT</i>
Trójfazowa <i>Three-phase</i>	A	H	B1	B2	B1 + B2	D1	D2	Kołnierz <i>Flanges</i>	P	L	H	kg
EVS 20-3	300	90	452	335	787	230	188	DN 50 2"	372	965	445	71,1
EVS 20-5	300	90	562	430	992	260	208	DN 50 2"	365	1115	440	100,4
EVS 20-7	300	90	652	430	1082	260	208	DN 50 2"	417	1215	445	108,9
EVS 20-10	300	90	875	490	1365	330	255	DN 50 2"	515	1515	493	157
EVS 20-14	300	90	1055	490	1545	330	255	DN 50 2"	515	1715	490	208,5

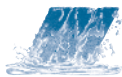

# EVS

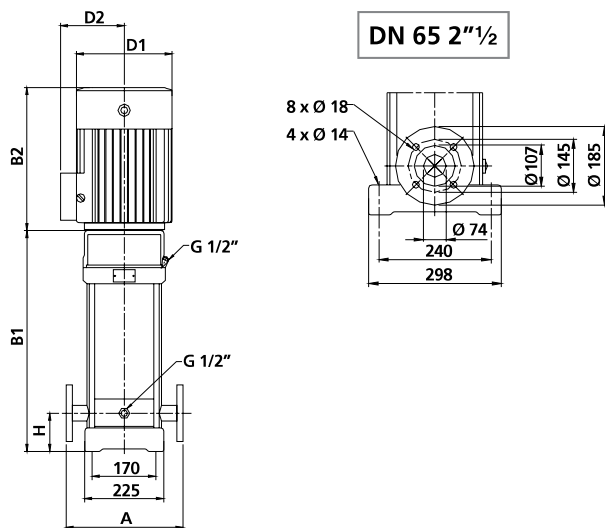
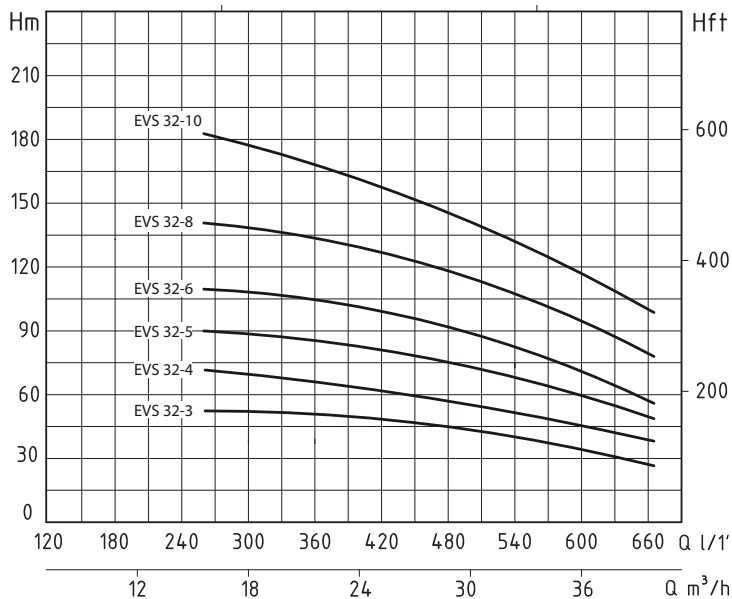

**DANE TECHNICZNE PRZY 2900 OBR./MIN. / TECHNICAL PERFORMANCE AT 2900 RPM**

Model <i>Model</i>	P2		A	Q (m³/h - l/min)							
				16	18	20	24	28	32	36	40
3~	HP	kW	3x400V	266	300	333	400	466	573	600	666
				Całkowita wysokość podnoszenia w m słupa wody <i>Total head in meters w.c.</i>							
EVS 32-3	7,5	5,5	10,7	54	52	51	48	44	40	35	27
EVS 32-4	10	7,5	14,5	72	70	69	65	59	53	47	37
EVS 32-5	15	11	16	90	88	86	81	74	67	59	47
EVS 32-6	15	11	19,4	108	104	102	97	90	81	72	57
EVS 32-8	20	15	24,5	144	140	138	130	120	109	97	77
EVS 32-10	25	18,5	32	182	176	173	164	152	138	122	98

MODEL POMPY <i>PUMP'S MODEL</i>	WYMIARY POMPY mm <i>PUMP'S DIMENSIONS mm</i>								WYMIARY OPAKOWANIA mm <i>PACKING DIMENSIONS mm</i>			WAGA <i>WEIGHT</i>
Trójfazowa <i>Three-phase</i>	A	H	B1	B2	B1 + B2	D1	D2	Kołnierz <i>Flanges</i>	P	L	H	kg
EVS 32-3	320	105	645	430	1075	260	208	DN 65 2" 1/2	417	1215	444	120,2
EVS 32-4	320	105	715	430	1145	260	208	DN 65 2" 1/2	417	1215	444	130,8
EVS 32-5	320	105	890	490	1380	330	255	DN 65 2" 1/2	515	1515	493	218,1
EVS 32-6	320	105	960	490	1450	330	255	DN 65 2" 1/2	515	1515	493	222,1
EVS 32-8	320	105	1100	490	1590	330	255	DN 65 2" 1/2	515	1715	490	241,5
EVS 32-10	320	105	1240	550	1790	330	255	DN 65 2" 1/2	515	1915	495	264

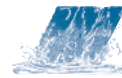

PIONOWE, WIELOSTOPNIOWE POMPY ELEKTRYCZNE ZE STALI NIERDZEWNEJ  
**VERTICAL MULTISTAGE STAINLESS STEEL ELECTRIC PUMPS**

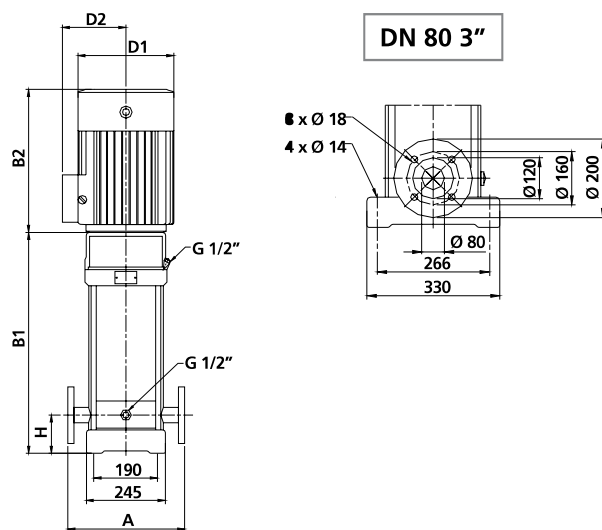
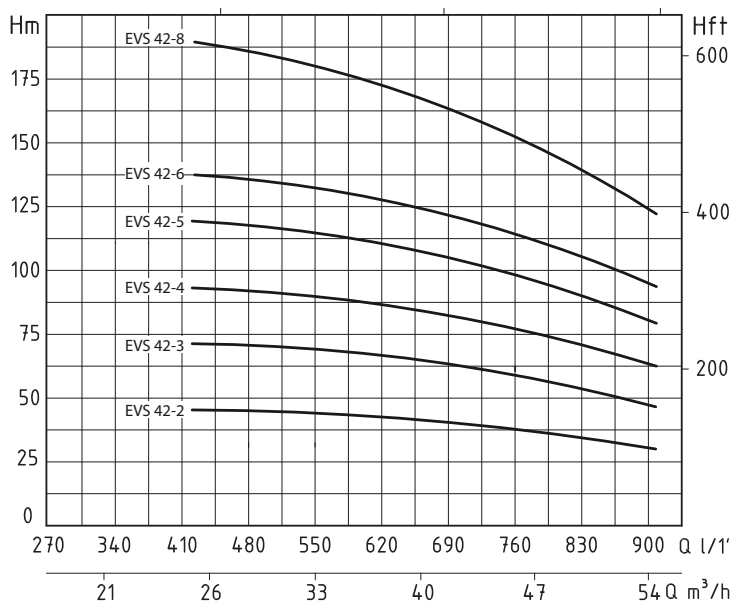

**DANE TECHNICZNE PRZY 2900 OBR./MIN. / TECHNICAL PERFORMANCE AT 2900 RPM**

Model <i>Model</i>	P2		A	Q (m <sup>3</sup> /h - l/min)							
				25	30	35	40	42	45	50	55
3~	HP	kW	3x400V	416	500	583	666	700	750	832	916
				Całkowita wysokość podnoszenia w m słupa wody <i>Total head in meters w.c.</i>							
EVS 42-2	10	7,5	14,5	48	46	44	42	41	39	35	31
EVS 42-3	15	11	19,4	71	69	66	63	61	58	53	47
EVS 42-4	20	15	27	95	92	88	84	81	78	71	62
EVS 42-5	25	18,5	33	119	115	110	105	101	97	88	78
EVS 42-6	30	22	39,5	143	138	132	125	122	116	106	93
EVS 42-8	40	30	55,5	190	184	176	167	162	154	141	124

MODEL POMPY <i>PUMP'S MODEL</i>	WYMIARY POMP mm <i>PUMP'S DIMENSIONS mm</i>							WYMIARY OPAKOWANIA mm <i>PACKING DIMENSIONS mm</i>			WAGA <i>WEIGHT</i>	
Trójfazowa <i>Three-phase</i>	A	H	B1	B2	B1 + B2	D1	D2	Kołnierz <i>Flanges</i>	P	L	H	kg
EVS 42-2	365	140	641	430	1071	260	208	DN 80 3"	417	1215	445	138,1
EVS 42-3	365	140	826	490	1316	330	255	DN 80 3"	515	1515	493	225
EVS 42-4	365	140	906	490	1396	330	255	DN 80 3"	515	1515	493	239
EVS 42-5	365	140	986	550	1536	330	255	DN 80 3"	515	1715	490	261,5
EVS 42-6	365	140	1066	590	1656	360	285	DN 80 3"	615	1965	545	301
EVS 42-8	365	140	1226	660	1886	400	310	DN 80 3"	615	1965	545	391



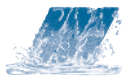

# EVS

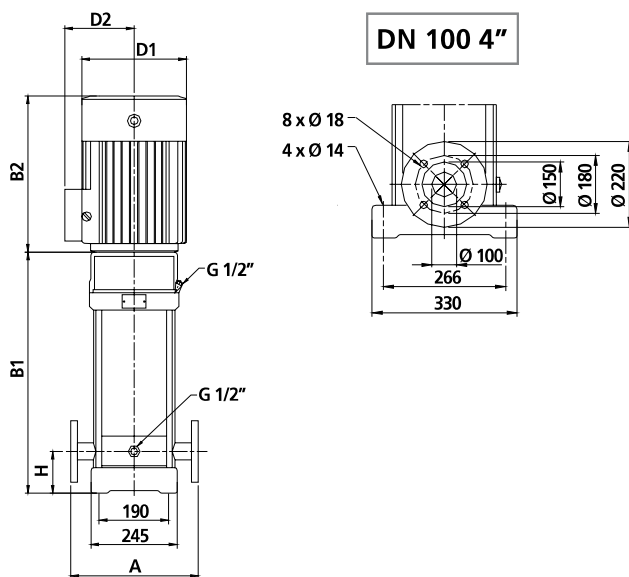
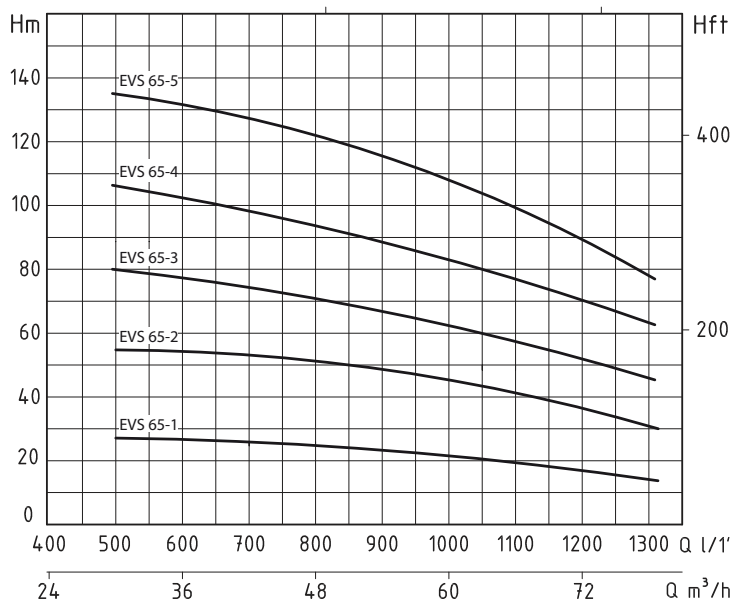

**DANE TECHNICZNE PRZY 2900 OBR./MIN. / TECHNICAL PERFORMANCE AT 2900 RPM**

Model <i>Model</i>	P2		A	Q (m <sup>3</sup> /h - l/min)							
				30	40	50	60	65	70	80	
3~	HP	kW	3x400V	500	666	832	1000	1083	1166	1333	
				Całkowita wysokość podnoszenia w m słupa wody <i>Total head in meters w.c.</i>							
EVS 65-1	7,5	5,5	10,7	27	25	23	21	20	18	15	
EVS 65-2	15	11	19,4	53	51	47	43	40	37	30	
EVS 65-3	25	18,5	27,5	80	76	70	64	60	55	46	
EVS 65-4	30	22	37	107	101	94	85	80	74	61	
EVS 65-5	40	30	48,5	136	129	119	109	102	94	78	

MODEL POMPY <i>PUMP'S MODEL</i>	WYMIARY POMPY mm <i>PUMP'S DIMENSIONS mm</i>								WYMIARY OPAKOWANIA mm <i>PACKING DIMENSIONS mm</i>			WAGA <i>WEIGHT</i>
Trójfazowa <i>Three-phase</i>	A	H	B1	B2	B1 + B2	D1	D2	Kołnierz <i>Flanges</i>	P	L	H	kg
EVS 65-1	365	140	561	430	991	260	208	DN 100 4"	417	1215	445	128,7
EVS 65-2	365	140	754	490	1244	330	255	DN 100 4"	515	1515	493	182
EVS 65-3	365	140	836	550	1386	330	255	DN 100 4"	515	1515	493	248
EVS 65-4	365	140	919	590	1509	360	285	DN 100 4"	515	1515	493	285
EVS 65-5	365	140	1001	660	1661	400	310	DN 100 4"	515	1715	490	345