

ARVEN®

W A T E R   P U M P S

ARVEN Official Catalogue 2019

About

ARVEN SRL nasce nel 1994 sfruttando la precedente esperienza pluriennale nel settore della famiglia Grazioli.

ARVEN SRL was set up in 1994 thanks to the previous experience of Grazioli family.





Lavorazioni-Machining

|1

**Deformazione
a freddo dell'acciaio**
*Deep cold forming of
stainless steel*



|2

Avvolgimenti elettrici
Electric motor windings



|3

**Alberi con saldatura
in acciaio AISI316**
*Shafts with welding
in stainless steel*



|4

**Assemblaggio e finitura e
test di collaudo**
*Assembling, finishing
and testing*



|5

**Componenti fonderia
di fusione in ghisa e acciaio**
*Foundry components iron
casting and stainless steel casting*





ARVEN Official Catalogue 2019

Quality



L'Azienda ARVEN Srl primeggia in particolare nel mercato delle pompe sommergibili in acciaio inox, grazie all'esperienza e al know-how sviluppati direttamente nel mercato con l'ausilio di una moderna sala prove interna, diventando quindi un punto di riferimento nel suo settore. La progettazione accurata e la realizzazione mediante le più moderne tecnologie, assicurano ai nostri prodotti uno standard di qualità elevato e costante. I nostri articoli vengono distribuiti con successo sul mercato coperti dalla garanzia, attestante che ogni pezzo prodotto dalla ARVEN è stato sottoposto ed ha superato tutta una serie di controlli richiesti dalle normative e dai capitoli qualitativi internazionali vigenti. L'azienda dispone inoltre di un magazzino rifornito di tutti i ricambi della produzione e quindi è in grado di garantire una solerte e veloce evasione di ogni ordinazione per soddisfare le richieste dei clienti.



The ARVEN SRL company takes the lead in particular in the market of stainless steel submersible pumps thanks to the experience and know-how developed directly on the market with the help of a modern internal test room, becoming a point of reference in this sector. Accurate design and implementation using the most modern technologies assure to the our products a high and constant standard. The products are distributed on the market covered by the "Quality Control" guarantee certifying that each item produced by ARVEN has gone through a series of controls required by the regulations and by international quality specifications. The company has a warehouse provided with all the components of the production and therefore it is able to guarantee a diligent and quick execution of each order to meet customer requirements.



14

SERIE MIZAR 30 - 60 - 75 - 60 vox - 75 vox SERIES

ELETTROPOMPE SOMMERSIBILI PER ACQUE CHIARE E SPORCHE
 SUBMERSIBLE ELECTRIC PUMPS FOR WHITE AND DIRTY WATER DRAINAGE



17

SERIE VERTICAL 30 - 60 - 75 - 60 vox - 75 vox SERIES

ELETTROPOMPE SOMMERSIBILI PER ACQUE CHIARE E SPORCHE CON GALLEGGIANTE
 VERTICALE
 SUBMERSIBLE ELECTRIC PUMPS FOR WHITE AND DIRTY WATER DRAINAGE WITH
 VERTICAL FLOATER

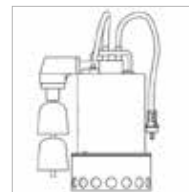

18

SERIE LOWER 30 - 60 SERIES

ELETTROPOMPE SOMMERSIBILI PER ACQUE CHIARE CON ASPIRAZIONE
 RIBASSATA 2 MM
 SUBMERSIBLE ELECTRIC PUMPS FOR WHITE AND DIRTY WATER DRAINAGE WITH
 2 MM LOWERED ASPIRATION

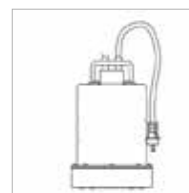

20

SERIE MIZAR 30/S - 60/S - 60/S vox AISI 316 SERIES

ELETTROPOMPE SOMMERSIBILI DRENAGGIO PER ACQUE CHIARE, SPORCHE E LIQUIDI
 AGGRESSIVI
 SUBMERSIBLE ELECTRIC PUMPS FOR WHITE, DIRTY WATERS AND AGGRESSIVE
 LIQUIDS DRAINAGE



24

SERIE REGAL "PROFESSIONAL"**80-100-150 - 100 vox - 150 vox - 200 vox SERIES**

ELETTROPOMPE SOMMERSIBILI DRENAGGIO PER ACQUE SPORCHE E
 LEGGERMENTE SABBIOSE
 SUBMERSIBLE ELECTRIC PUMPS FOR DIRTY AND LIGHTLY SANDY WATERS DRAINAGE

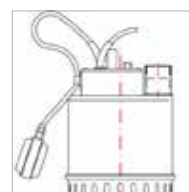

28

SERIE KONTRACT 180 - 250 SERIES

ELETTROPOMPE SOMMERSIBILI DRENAGGIO PER CANTIERISTICA
 SUBMERSIBLE ELECTRIC PUMPS FOR CONSTRUCTION WORK SITE DRAINAGE

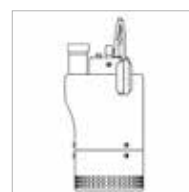

32

SERIE KONTRACT 300 - 400 - 600 SERIES

ELETTROPOMPE SOMMERSIBILI DRENAGGIO PER CANTIERISTICA
 SUBMERSIBLE ELECTRIC PUMPS FOR CONSTRUCTION WORK SITE DRAINAGE



36

SERIE KONTRACT 550 - 750 - 1250 - 1500 SERIES

ELETTROPOMPE SOMMERSIBILI DRENAGGIO PER CANTIERISTICA
 SUBMERSIBLE ELECTRIC PUMPS FOR CONSTRUCTION WORK SITE DRAINAGE



- 40 **SERIE SPRING 30 - 60 - 80 - 100 - 150 SERIES**
ELETTROPOMPE SOMMERGIBILI PER FONTANE E SVUOTAMENTO PISCINE
SUBMERSIBLE ELECTRIC PUMPS FOR FOUNTAINS AND SWIMMING POOL EMPTYING OPERATIONS
- 44 **SERIE DUMPER 70 - 80 - 100 - 140 SERIES**
ELETTROPOMPE SOMMERGIBILI DRENAGGIO PER ACQUE SPORCHE
SUBMERSIBLE ELECTRIC PUMPS FOR FOUL WASTEWATER DRAINAGE
- 48 **SERIE DUMPER 150 - 200 - 300 SERIES**
ELETTROPOMPE SOMMERGIBILI DRENAGGIO PER ACQUE SPORCHE
SUBMERSIBLE ELECTRIC PUMPS FOR FOUL WASTEWATER DRAINAGE
- 52 **SERIE TIGER 70 - 80 - 100 - 150 - 200 SERIES**
ELETTROPOMPE SOMMERGIBILI VORTEX E BICANALI PER ACQUE CARICHE
SUBMERSIBLE VORTEX AND TWIN-CHANNEL IMPELLERS ELECTRIC PUMPS FOR WASTE WATER
- 58 **SERIE TIGER 80F - 100F - 140F - 150F - 190F - 200F - 300F - 400F SERIES**
ELETTROPOMPE SOMMERGIBILI VORTEX PER ACQUE CARICHE, DOTATE DI CONTROFLANGIA
SUBMERSIBLE VORTEX ELECTRIC PUMPS FOR WASTE WATER, FEATURING A COUNTER FLANGE
- 62 **SERIE SKIPPER 80F - 100F - 140F - 150F - 190F - 200F - 300F - 400F SERIES**
ELETTROPOMPE SOMMERGIBILI VORTEX PER ACQUE CARICHE, DOTATE DI CONTROFLANGIA
SUBMERSIBLE VORTEX ELECTRIC PUMPS FOR WASTE WATER, FEATURING A COUNTER FLANGE
- 66 **SERIE SKIPPER 80 - 100 - 150 - 200 SERIES**
ELETTROPOMPE SOMMERGIBILI VORTEX PER ACQUE CARICHE
SUBMERSIBLE VORTEX ELECTRIC PUMPS FOR WASTEWATER
- 70 **SERIE ARVEX 80/S - 100/S - 150/S - 200/S BC Aisi 316 SERIES**
ELETTROPOMPE SOMMERGIBILI VORTEX E BICANALI PER ACQUE CARICHE E LIQUIDI AGGRESSIVI
SUBMERSIBLE VORTEX AND TWIN-CHANNEL IMPELLERS ELECTRIC PUMPS FOR WASTEWATER AND AGGRESSIVE LIQUIDS

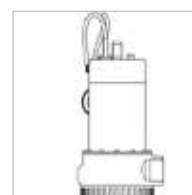

76

SERIE ARVEX 80 - 100 - 150 - 200 Aisi 304 SERIES

ELETTROPOMPE SOMMERSIBILI VORTEX E BICANALI PER ACQUE CARICHE
SUBMERSIBLE VORTEX AND TWIN-CHANNEL IMPELLERS ELECTRIC PUMPS FOR WASTEWATER



82

SERIE RIVER 150F - 200F - 300F - 400F - 600F SERIES

ELETTROPOMPE SOMMERSIBILI MONOCANALI PER ACQUE CARICHE, DOTATE DI CONTROFLANGIA

SUBMERSIBLE SINGLE CHANNEL ELECTRIC PUMPS FOR VERY FOUL WASTE WATER, FEATURING A COUNTER FLANGE

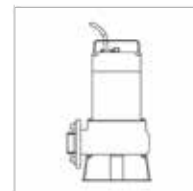

86

SERIE TENAX 150F - 200F - 300F - 400F - 600F SERIES

ELETTROPOMPE SOMMERSIBILI MONOCANALI PER ACQUE CARICHE DOTATE DI CONTROFLANGIA

SUBMERSIBLE SINGLE CHANNEL ELECTRIC PUMPS FOR VERY FOUL WASTE WATER, FEATURING A COUNTER FLANGE



90

SERIE CUTTER 140 - 150 - 200 - 300 SERIES

ELETTROPOMPE SOMMERSIBILI TRITURATRICI PER ACQUE SPORCHE E CARICHE
GRINDER SUBMERSIBLE ELECTRIC PUMPS FOR FOUL AND HEAVY WASTE WATER

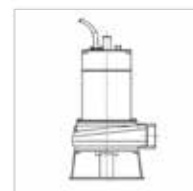

94

SERIE ROXY 75 - 85 SERIES

ELETTROPOMPE SOMMERSIBILI MULTISTADIO
VERTICAL SUBMERSIBLE SINGLE-BLOCK MULTISTAGE

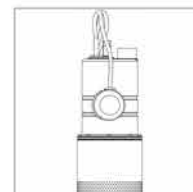

98

SERIE ROXY 80 - 100- 120 - 160 SERIES 

ELETTROPOMPE SOMMERSE MONOBLOCCO MULTISTADIO VERTICALI PER POZZI DA 5 POLLICI

VERTICAL SUBMERSIBLE SINGLE BLOCK MULTISTAGE ELECTRIC PUMPS FOR 5 INCH WELLS

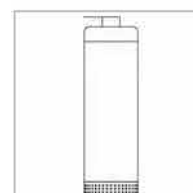

102

SERIE GPV.RX 100 - 150 - 200 SERIES

ELETTROPOMPE SOMMERSE MONOBLOCCO MULTISTADIO VERTICALI PER POZZI DA 6 POLLICI

VERTICAL SUBMERSIBLE SINGLE BLOCK MULTISTAGE ELECTRIC PUMPS FOR 6 INCH WELLS



106

SERIE WORKER 250 - 350 SERIES

ELETTROPOMPE SOMMERSE MONOBLOCCO MULTISTADIO VERTICALI PER POZZI DA 8 E 10 POLLICI

VERTICAL SUBMERSIBLE SINGLE BLOCK MULTISTAGE ELECTRIC PUMPS FOR 8 AND 10 INCH WELLS

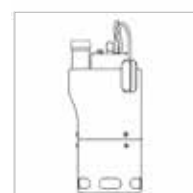

POMPE SOMMERGIBILI INOX - *SUBMERSIBLE INOX PUMPS*

- 110 **SERIE WORKER 300 - 400 - 500 - 750 - 1000 SERIES**
ELETTROPOMPE SOMMERSE MONOBLOCCO MULTISTADIO VERTICALI PER POZZI DA 8
E 10 POLLICI
*VERTICAL SUBMERSIBLE SINGLE BLOCK MULTISTAGE ELECTRIC PUMPS FOR 8 AND
10 INCH WELLS*

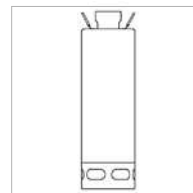

- 114 **SISTEMI DI DISCESA (DN 50 - DN 80) PER IMPIANTI FISSI**
GUIDE RAIL SYSTEMS (DN50 - DN80) FOR FIXED PLANTS

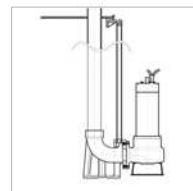

- 116 **SERIE BOX - 1 / SERIE BOX - 2**
STAZIONI AUTOMATICHE PER LA RACCOLTA E IL SOLLEVAMENTO DI ACQUE CARICHE
AUTOMATIC STATIONS FOR COLLECTING AND LIFTING WASTE WATER

POMPE SOMMERGIBILI IN GHISA - *SUBMERSIBLE PUMPS IN CAST IRON*

- 118 **SERIE TURBO 200 - 250 SERIES**
ELETTROPOMPE SOMMERGIBILI MONOBLOCCO MULTISTADIO VERTICALI
VERTICAL SUBMERSIBLE MULTI-STAGE ELECTRIC PUMPS

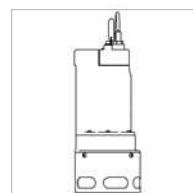

- 122 **SERIE TURBO 300 - 400 - 500 SERIES**
ELETTROPOMPE SOMMERGIBILI MONOBLOCCO MULTISTADIO VERTICALI
VERTICAL SUBMERSIBLE MULTI-STAGE ELECTRIC PUMPS



- 126 **SERIE TURBO 750 - 1000 SERIES**
ELETTROPOMPE SOMMERGIBILI MONOBLOCCO MULTISTADIO VERTICALI
VERTICAL SUBMERSIBLE MULTI-STAGE ELECTRIC PUMPS

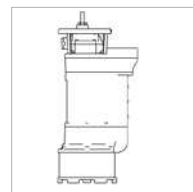

- 130 **SERIE TURBO-L 200 SERIES**
ELETTROPOMPE SOMMERGIBILI DRENAGGIO PER ACQUE SPORCHE E LEGGERMENTE
SABBIOSE
SUBMERSIBLE ELECTRIC PUMPS FOR LIGHTLY SANDY FOUL WASTEWATER DRAINAGE

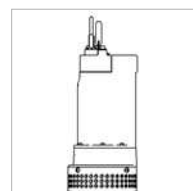

- 134 **SERIE TURBO-LG 250 - 350 SERIES**
ELETTROPOMPE SOMMERGIBILI DRENAGGIO PER CANTIERISTICA
SUBMERSIBLE ELECTRIC PUMPS FOR COSTRUCTION WORK SITE DRAINAGE

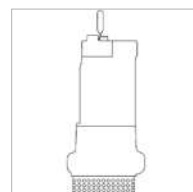

POMPE SOMMERGIBILI IN GHISA SUBMERSIBLE PUMPS IN CAST IRON

138

SERIE TURBO-LG 500 ÷ 1500

ELETTROPOMPE SOMMERGIBILI DRENAGGIO PER CANTIERISTICA
SUBMERSIBLE ELECTRIC PUMPS FOR CONSTRUCTION WORK SITE DRAINAGE

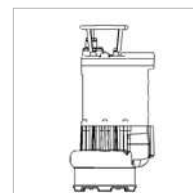

144

SERIE TURBO-TC 200 - 300 - 400 SERIES

ELETTROPOMPE SOMMERGIBILI PER ACQUE CARICHE
SUBMERSIBLE TWIN CHANNEL ELECTRIC PUMPS FOR WASTEWATER

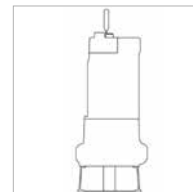

POMPE SOMMERSE - SUBMERSIBLE PUMPS

148

SERIE RED TURBO-J 100-150 BS - 150 BP SERIES

ELETTROPOMPE PERIFERICHE SOMMERSE PER POZZI DA 4"
PERIPHERAL SUBMERSED ELECTRIC PUMPS, FOR 4" WELLS

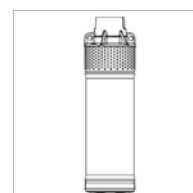

152

SERIE AP SERIES

ELETTROPOMPE SOMMERSE PER POZZI DA 4" INTERAMENTE IN ACCIAIO INOX
SUBMERSIBLE ELECTRIC PUMPS, FOR 4 INCH WELLS FULLY IN STAINLESS STEEL

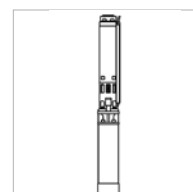

156

SERIE ST

ELETTROPOMPE SOMMERSE PER POZZI DA 4"
SUBMERSIBLE ELECTRIC PUMPS, FOR 4 INCH WELLS

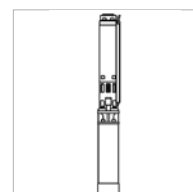

MOTORI SOMMERSI - SUBMERSIBLE MOTORS

164

SERIE OPM SERIES

MOTORE ELETTRICO 4"
SUBMERSIBLE MOTOR 4"

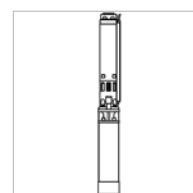

POMPE SOMMERGIBILI IN PLASTICA - PLASTIC SUBMERSIBLE PUMPS

165

SERIE NCC 24 SERIES

POMPE SOMMERGIBILI IN PLASTICA 24 VOLT (DRENAGGIO)
PLASTIC SUBMERSIBLE PUMPS 24 VOLT (DRAINAGE)

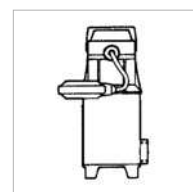

166

SERIE NCC 24T SERIES

POMPE SOMMERGIBILI IN PLASTICA 24 VOLT (VORTEX)
PLASTIC SUBMERSIBLE PUMPS 24 VOLT (VORTEX)



168

SERIE SPA E SPM SERIES

POMPE SOMMERGIBILI PER ACQUE CHIARE E SPORCHE
 SUBMERSIBLE PUMPS FOR WHITE AND DURTY WATER

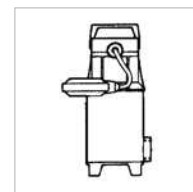

169

SERIE MAXIMA SERIES

POMPE SOMMERGIBILI PER ACQUE SPORCHE (VORTEX)
 SUBMERSIBLE PUMPS FOR DURTY WATER (VORTEX)

**POMPE DI SUPERFICIE - SURFACE PUMPS**

170

SERIE PMF 50 - 100 - 150 - 200 SERIES

ELETTROPOMPE PERIFERICHE
 PERIPHERICAL ELECTRIC PUMPS

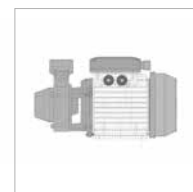

174

SERIE JET 90 - 100 - 150 - 200 SERIES

ELETTROPOMPE AUTOADESCANTI IN GHISA
 SELF PRIMING ELECTRIC PUMPS IN CAST IRON

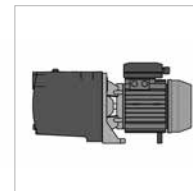

178

SERIE JETX 90 - 100 SERIES

ELETTROPOMPE AUTOADESCANTI (INOX AISI 304)
 SELF PRIMING ELECTRIC PUMPS (INOX AISI 304)

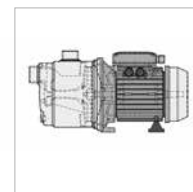

182

SERIE R 50 - 75 - 100 - 150 - 200 - 300 SERIES

ELETTROPOMPE CENTRIFUGHE, MONOGIRANTI
 CENTRIFUGAL ELECTRIC PUMPS, SINGLE-IMPELLERS

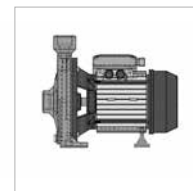

186

SERIE RB 100 - 150 - 200 - 300 - 400 - 550 - 750 SERIES

ELETTROPOMPE CENTRIFUGHE, BIGIRANTI
 CENTRIFUGAL ELECTRIC PUMPS, DOUBLE IMPELLERS

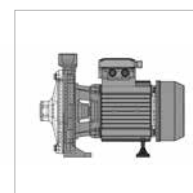

190

SERIE RPG 75 - 100 SERIES

ELETTROPOMPE CENTRIFUGHE MULTICELLULARI IN GHISA
 CENTRIFUGAL MULTISTAGE ELECTRIC PUMPS CAST IRON PUMPS

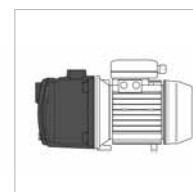

194

SERIE RPX 90 - 130 SERIES

ELETTROPOMPE CENTRIFUGHE MULTICELLULARI (INOX AISI 304)
 MULTISTAGE CENTRIFUGAL ELECTRIC PUMPS (INOX AISI 304)

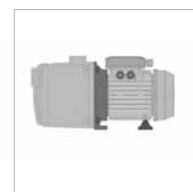

POMPE DI SUPERFICIE - SURFACE PUMPS

198

SERIE RM 80 - 100 - 150 SERIES

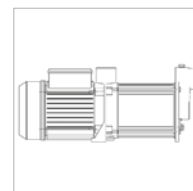
ELETTROPOMPE CENTRIFUGHE MULTICELLULARI (INOX AISI 304)
MULTISTAGE CENTRIFUGAL ELECTRIC PUMPS (INOX AISI 304)

202

SERIE RMX SERIES

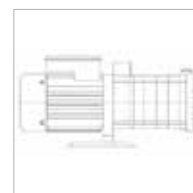
ELETTROPOMPE CENTRIFUGHE MULTICELLULARI INTEGRALMENTE ACCIAIO INOX AISI 304
MULTISTAGE CENTRIFUGAL ELECTRIC STAINLESS STEEL PUMPS (INOX AISI 304)

206

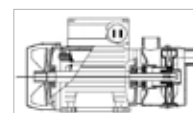
SERIE PEM **NEW**ELETTROPOMPE AUTODESCANTI A CANALE LATERALE IN OTTONE
SELF-PRIMING SIDE CHANNEL PUMPS IN BRASS

208

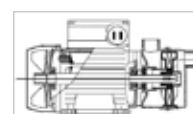
SERIE PXM **NEW**ELETTROPOMPE AUTODESCANTI A CANALE LATERALE IN ACCIAI INOX AISI316
SELF-PRIMING SIDE CHANNEL PUMPS IN AISI316 STAINLESS STEEL

210

SERIE CR 80 - 100 - 150 - 200 - 250 SERIES

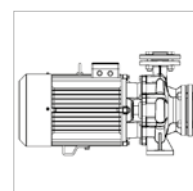
ELETTROPOMPE CENTRIFUGHE MONOBLOCCO
MONOBLOCK CENTRIFUGAL PUMPS

GRUPPI DI PRESSURIZZAZIONE - PRESSURE SYSTEM

218

SERIE PS 2-RB - PI 2-RB - PS 2-RM SERIES

GRUPPI DI PRESSURIZZAZIONE
PRESSURE SYSTEM

MOTOPOMPE - GASOLINE WATER PUMPS

220

SERIE GMA 0225-0425-0430-0440 SERIES

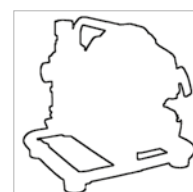
MOTOPOMPE AUTODESCANTI PORTATILI
SELFPRIMING HAND-CARRY MOTOR PUMPS

POMPE A MANO - HANDS PUMPS

224

SERIE K 300 - 400 - 500 - 600 SERIES

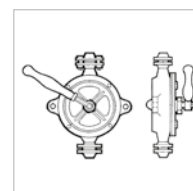
POMPE A MANO SEMI ROTATIVE
SEMI ROTATING HAND PUMPS

226

SERIE NP 600 - 650 SERIES

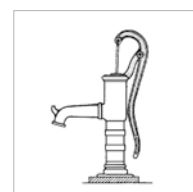
POMPE A MANO ASPIRANTI VERTICALI
HAND OPERATED VERTICAL SUCTION PUMPS

228

ACCESSORI E TABELLE RESISTENZE CHIMICHE
ACCESSORIES AND RESISTANCE CHEMICAL TABLES

MIZAR



ELETTROPOMPE SOMMERGIBILI DRENAGGIO PER ACQUE CHIARE E SPORCHE SUBMERSIBLE ELECTRIC PUMPS FOR WHITE AND DIRTY WATER DRAINAGE

PREVALENZA : 8,0 mt. ÷ 11,5 mt.
PORTATA : 9,0 m³/h ÷ 12 m³/h
POTENZA NOMINALE : 0,25 kW (0,33 HP) ÷ 0,55 kW (0,75 HP)
PASSAGGIO SOLIDI FINO A 10 mm (SERIE VOX 20 mm)

PUMP HEAD : 8,0 mt ÷ 11,5mt
DELIVERY : 9,0 m³/h ÷ 12 m³/h
RATED HORSEPOWER : 0,25 kW (0,33 HP) ÷ 0,55 kW (0,75 HP)
SOLID MATTER BYPASS up to 10 mm (SERIE VOX 20 mm)

APPLICAZIONI

- SVUOTAMENTO DA ACQUE PIOVANE, D'INFILTRAZIONE, DI POZZETTI O VASCHE DI RACCOLTA.
- PRELIEVO DA VASCHE DI RACCOLTA DI ACQUE PIOVANE PER PICCOLE IRRIGAZIONI A SCORRIMENTO DI ORTI E DI GIARDINI.
- TRAVASO DI ACQUA CHIARA DA SERBATOI E VASCHE.
- POMPAGGIO DI ACQUE SPORCHE CON CORPI SOLIDI IN SOSPENSIONE (SOLO SERIE VOX).

APPLICATIONS

- RAIN, SEEPAGE, SUMP PIT AND CATCH TANK WATER PUMP OUT.
- GARDEN AND VEGETABLE-GARDEN MINI FLOOD IRRIGATION SYSTEM RAINWATER CATCH TANK PUMP DOWN.
- WHITE WATER PUMP OVER FROM RESERVOIRS AND VATS.
- PUMPING DIRTY WATER WITH POSSIBLE FLOATING SOLID CONTENTS (ONLY VOX SERIES).
- PUMPING AGGRESSIVE LIQUID.

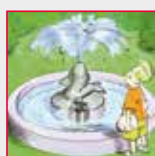

CARATTERISTICHE DI COSTRUZIONE:

- MOTORE A SECCO RAFFREDDATO DAL LIQUIDO POMPATO
- DOPPIA TENUTA MECCANICA: DOPPIO ANELLO DI TENUTA LATO MOTORE, TENUTA MECCANICA A BAGNO D'OLIO LATO POMPA
- IMMERSIONE MASSIMA: mt. 5.
- GRADO DI PROTEZIONE IP 68.
- CLASSE DI ISOLAMENTO: F
- TEMPERATURA MAX.LIQUIDO POMPATO: 35°C
- PASSAGGIO LIBERO: 10 mm MIZAR 30 - 60 - 75
20mm MIZAR 60 VOX - 75 vox
- VERSIONI: Monofase: 220-277V/50Hz o 220-277V/60Hz con protettore termico incorporato e condensatore permanentemente inserito.
- CAVO STANDARD:
Monofase: 10 metri H07RN-F per versione normale (aut.-man).
5 metri H07RN-F solo per versione automatica.

SPECIALI VOLTAGGI E FREQUENZE A RICHIESTA.

DESIGN ENGINEERING:

- SEMI WET MOTOR WATERCOOLED
- DOUBLE MECHANICAL SEAL: DOUBLE SEAL RING -ENGINE FACE
OIL BATH MECHANICAL SEALS PUMP FACE
- PERMISSIBLE DRAUGHT OF WATER: 5 m
- IP 68 PROTECTION CLASS.
- CLASS "F" INSULATION.
- MAX. PUMPED LIQUID TEMPERATURE: 35°C
- BY PASS SECTION: 10 mm MIZAR 30 - 60 - 75
20mm MIZAR 60 VOX - 75 vox
- VERSIONS: Single Phase: 220-277V/50Hz or 220-277V/60Hz with built in thermal protection and permanent capacitor.
- STANDARD CABLE FEATURES:
Single phase: 10 metres H07RN-F for the standard version (automatic-manual).
5 metres H07RN-F only for the automatic version.

CUSTOMISED VOLTAGE AND FREQUENCY RATING AVAILABLE ON DEMAND.

TABELLA MATERIALI - MATERIALS TABLE:

Pos.	Componente - Component	Materiale - Materials
A	Carcassa esterna / External motor housing	ACCIAIO INOX AISI 304 - DIN 1.4301 / STAINLESS STEEL
B	Girante / Impeller	MIZAR 30 - 60 TECNOPOLIMERO TECNOPOLYMER
		MIZAR 60 VOX ACCIAIO INOX (AISI 304 - DIN 1.4305) / STAINLESS STEEL
C	Albero (lato pompa) / Shaft (pump side)	ACCIAIO INOX AISI 303 - DIN 1.4005 / STAINLESS STEEL
D	Tenuta meccanica / Mechanical seal	Lato pompa / Pump face GRAFITE-CERAMICA GRAPHITE - CERAMIC
		Lato motore / Motor face DOPPIO ANELLO DI TENUTA NBR NBR DOUBLE SEALING RING
E	O-ring	NBR
F	Porta tenuta / Seal holder	ACCIAIO INOX AISI 304 - DIN 1.4301 / STAINLESS STEEL
G	Porta motore / Motor holder	TECNOPOLIMERO TECNOPOLYMER
H	Cassa motore / Motor housing	ACCIAIO INOX AISI 304 - DIN 1.4301 / STAINLESS STEEL
I	Coperchio / Cover	TECNOPOLIMERO TECNOPOLYMER
L	Diffusore / Diffuser	ACCIAIO INOX AISI 304 - DIN 1.4301 STAINLESS STEEL
N	Base d'aspirazione / Suction base	

MIZAR 30 - 60 - 75

MIZAR 60 VOX - 75 VOX

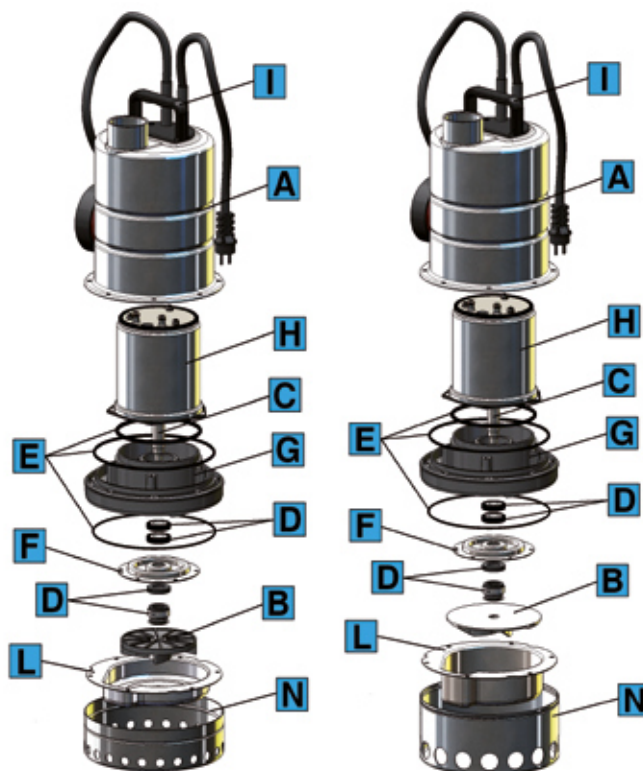

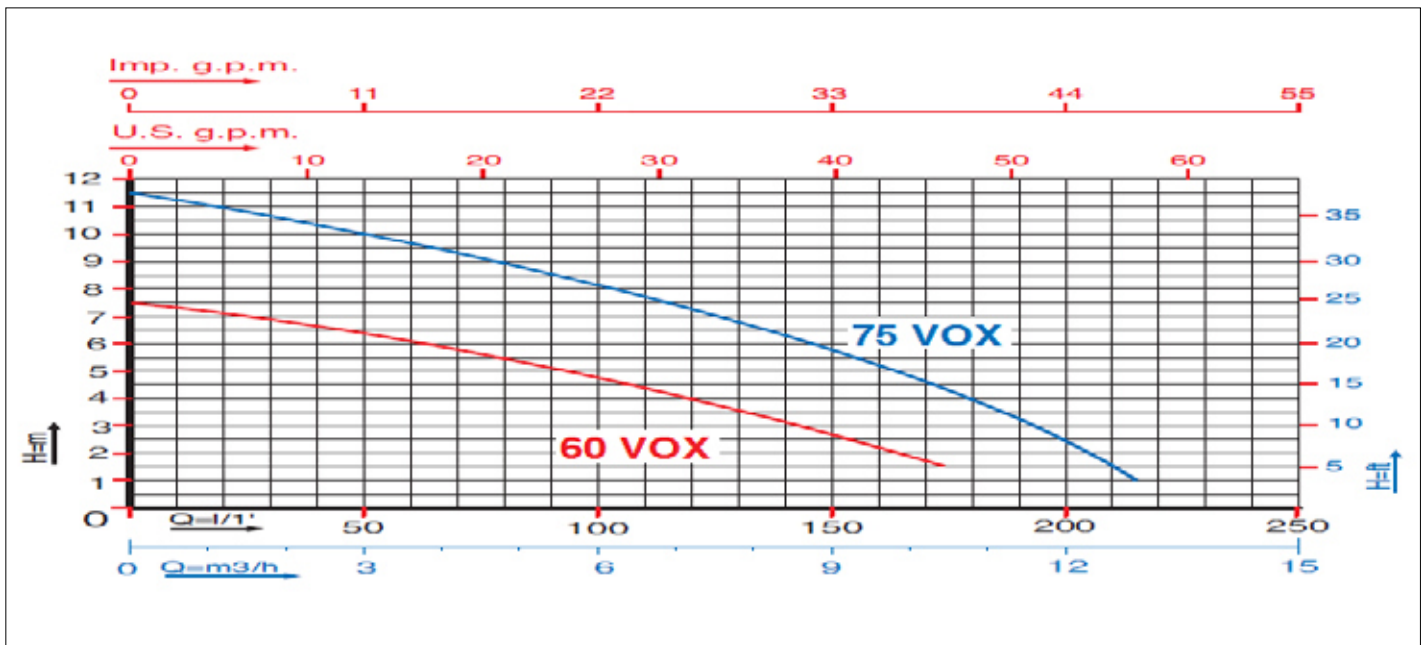
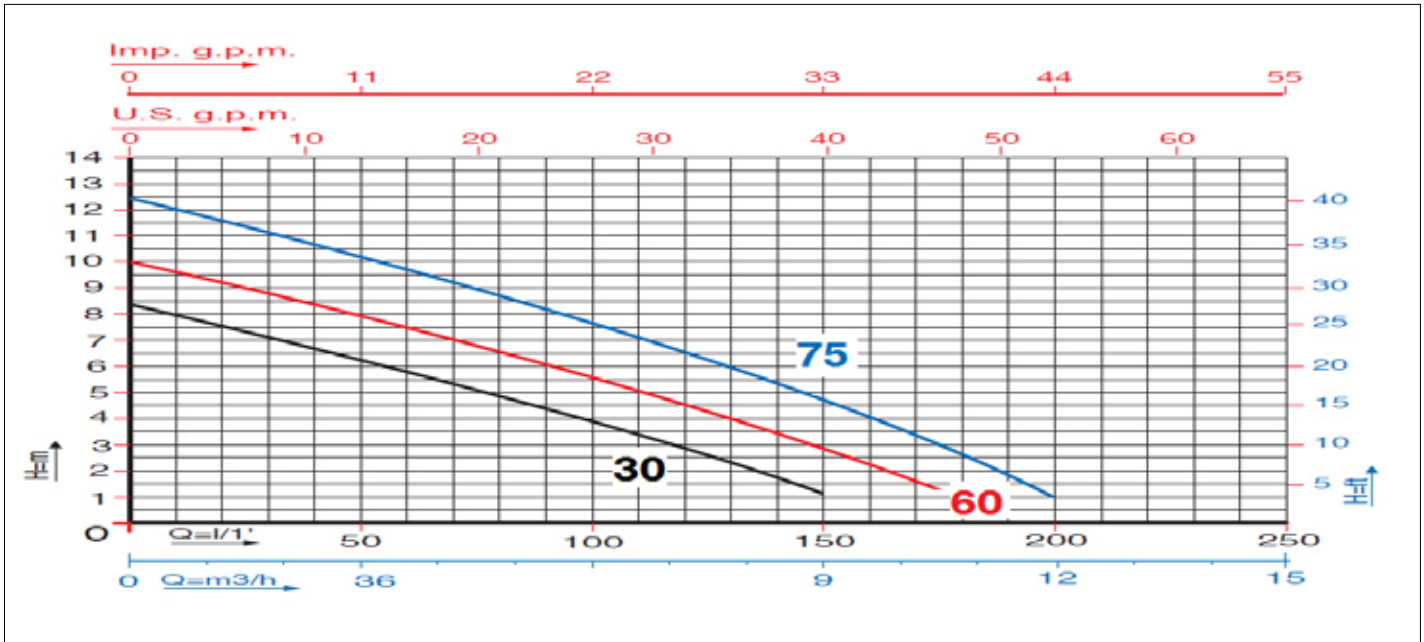

Caratteristiche di funzionamento a 2800 rpm 50Hz e 3450 rpm 60Hz - Performances at 2800 rpm 50 Hz and 3450 rpm 60 Hz
 Le prestazioni valgono per liquidi con densità $\rho = 1,0 \text{ kg/dm}^3$ ed una viscosità $\nu = 1 \text{ mm}^2/\text{s}$ / The performance data holds true for liquids with a $\rho = 1,0 \text{ kg/dm}^3$ density and a $\nu = 1 \text{ mm}^2/\text{s}$ viscosity.

MODELLO MODEL	VOLTAGGIO VOLTAGE 50 Hz	DATI ELETTRICI / ELECTRICAL DATA						DATI IDRAULICI / HYDRAULIC DATA																			
		P1 max kW	P2 nom. kW	I max HP	I max Ampere	Condensatore Capacitor μF VC		m³/h		0	1,5	3	4,5	6	7,5	9	10,5	12	H (m)								
MIZAR 30 M	1 x 220-230V	0,5	0,25	0,33	2,2	8,0	450	H (m)	0	25	50	75	100	125	150	175	200	8,0	7,2	6,2	5,2	4,0	2,6	1,0	---	---	
MIZAR 60 M	1 x 220-230V	0,7	0,45	0,6	3,0	10,0	450		10,0	8,8	8,0	6,8	5,6	4,5	3,0	1,2	---	---	10,0	8,8	8,0	6,8	5,6	4,5	3,0	1,2	---
MIZAR 60 T	3 x 380-440V	0,7	0,45	0,6	1,4	---	---		10,0	8,8	8,0	6,8	5,6	4,5	3,0	1,2	---	---	12,5	11,4	10,2	8,9	7,6	6,3	4,7	2,9	1
MIZAR 75 M	1 x 220-230V	1,0	0,55	0,75	4,8	16,0	450		7,5	7,0	6,4	5,5	4,6	3,4	2,6	1,5	---	---	7,5	7,0	6,4	5,5	4,6	3,4	2,6	1,5	---
MIZAR 60 VOX M	1 x 220-230V	0,6	0,45	0,6	2,8	10,0	450		7,5	7,0	6,4	5,5	4,6	3,4	2,6	1,5	---	---	11,5	10,8	10,0	9,0	8,0	7,0	5,8	4,5	2,5
MIZAR 60 VOX T	3 x 380-440V	0,6	0,45	0,6	1,3	---	---		7,5	7,0	6,4	5,5	4,6	3,4	2,6	1,5	---	---	7,5	7,0	6,4	5,5	4,6	3,4	2,6	1,5	---
MIZAR 75 VOX M	1 x 220-230V	1,0	0,55	0,75	4,7	16,0	450	11,5	10,8	10,0	9,0	8,0	7,0	5,8	4,5	2,5	---	---	11,5	10,8	10,0	9,0	8,0	7,0	5,8	4,5	2,5

PRESSIONE TOTALE IN METRI COLONNA ACQUA
TOTAL PUMP HEAD AND WATER COLUMN HEIGHT IN m.

CARATTERISTICHE DI COSTRUZIONE:

- MOTORE A SECCO RAFFREDDATO DAL LIQUIDO POMPATO
- DOPPIA TENUTA MECCANICA: DOPPIO ANELLO DI TENUTA LATO MOTORE, TENUTA MECCANICA A BAGNO D'OLIO LATO POMPA
- IMMERSIONE MASSIMA: mt. 5.
- GRADO DI PROTEZIONE IP 68.
- CLASSE DI ISOLAMENTO: F
- TEMPERATURA MAX.LIQUIDO POMPATO: 35°C
- PASSAGGIO LIBERO: 10 mm MIZAR 30 - 60 - 75
20 mm MIZAR 60 VOX - 75 VOX
- VERSIONI: Monofase: 220-277V/50Hz o 220-277V/60Hz con protettore termico incorporato e condensatore permanentemente inserito.
- CAVO STANDARD: 10 metri H07RN-F.
- MATERIALI:
Consultare pagina 9

SPECIALI VOLTAGGI E FREQUENZE A RICHIESTA.

DESIGN ENGINEERING:

- SEMI WET MOTOR WATERCOOLED
- DOUBLE MECHANICAL SEAL: DOUBLE SEAL RING -ENGINE FACE
OIL BATH MECHANICAL SEALS PUMP FACE
- PERMISSIBLE DRAUGHT OF WATER: 5 m
- IP 68 PROTECTION CLASS.
- CLASS "F" INSULATION.
- MAX. PUMPED LIQUID TEMPERATURE: 35°C
- BY PASS SECTION: 10 mm MIZAR 30 - 60 - 75
20 mm MIZAR 60 VOX - 75 VOX
- VERSIONS: Single Phase: 220-277V/50Hz or 220-277V/60Hz with built in thermal protection and permanent capacitor.
- STANDARD CABLE FEATURES: 10 metres H07RN-F.
- MATERIALS:
Suitable at page 9

CUSTOMISED VOLTAGE AND FREQUENCY RATING AVAILABLE ON DEMAND.

GALLEGGIANTE VERTICALE

VERTICAL FLOATER



VERTICAL 30 - 60 - 60 VOX - 75 VOX

MODELLO MODEL	VOLTAGGIO VOLTAGE 50 HZ	DATI ELETTRICI / ELECTRICAL DATA						
		P1 max		P2 nom.		I max	Condensatore Capacitor	
		kW	kW	HP	Ampere	µF	VC	
VERTICAL 30 M	1 X 220-230 V	0,5	0,25	0,33	2,2	8	450	
VERTICAL 60 M	1 X 220-230 V	0,7	0,45	0,6	3,0	10	450	
VERTICAL 75 M	1 X 220-230 V	1,0	0,55	0,75	4,8	16	450	
VERTICAL 60 VOX M	1 X 220-230 V	0,6	0,45	0,6	2,8	10	450	
VERTICAL 75 VOX M	1 X 220-230 V	1,0	0,55	0,75	4,7	16	450	

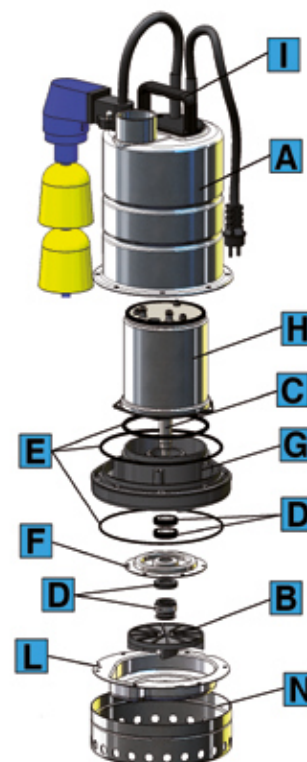

CARATTERISTICHE DI COSTRUZIONE:

- MOTORE A SECCO RAFFREDDATO DAL LIQUIDO POMPATO
- DOPPIA TENUTA MECCANICA: DOPPIO ANELLO DI TENUTA LATO MOTORE, TENUTA MECCANICA A BAGNO D'OLIO LATO POMPA
- IMMERSIONE MASSIMA: mt. 5.
- GRADO DI PROTEZIONE IP 68.
- CLASSE DI ISOLAMENTO: F
- TEMPERATURA MAX.LIQUIDO POMPATO: 35°C
- PASSAGGIO LIBERO: 2 mm.
- VERSIONI: Monofase: 220-277V/50Hz o 220-277V/60Hz con protettore termico incorporato e condensatore permanentemente inserito.
- CAVO STANDARD: 10 metri H07RN-F solo versione manuale.
- MATERIALI:
Consultare a pagina 9

SPECIALI VOLTAGGI E FREQUENZE A RICHIESTA.

ASPIRAZIONE RIBASSATA 2 MM

**VERSIONE ELETTRONICA E
ELECTRONIC VERSION E**



DESIGN ENGINEERING:

- SEMI WET MOTOR WATERCOOLED
- DOUBLE MECHANICAL SEAL: DOUBLE SEAL RING -ENGINE FACE OIL BATH MECHANICAL SEALS PUMP FACE
- PERMISSIBLE DRAUGHT OF WATER: 5 m
- IP 68 PROTECTION CLASS.
- CLASS "F" INSULATION.
- MAX. PUMPED LIQUID TEMPERATURE: 35°C
- BY PASS SECTION: 2 mm.
- VERSIONS: Single Phase: 220-277V/50Hz or 220-277V/60Hz with built in thermal protection and permanent capacitor.
- STANDARD CABLE FEATURES: 10 metres H07RN-F only the manual version
- MATERIALS:
Cuitable at page 9

CUSTOMISED VOLTAGE AND FREQUENCY RATING AVAILABLE ON DEMAND.

LOWERED ASPIRATION 2MM

**VERSIONE MANUALE
MANUAL VERSION**



MODELLO MODEL	VOLTAGGIO VOLTAGE	DATI ELETTRICI / ELECTRICAL DATA					
		P1 max	P2 nom.	I max	Condensatore Capacitor		
					kW	kW	HP
LOWER 30 M	1 x 220-230V	0,5	0,25	0,33	2,2	8,0	450
LOWER 30 M E	1 x 220-230V	0,5	0,25	0,33	2,2	8,0	450
LOWER 60 M	1 x 220-230V	0,7	0,45	0,6	3,0	10,0	450
LOWER 60 M E	1 x 220-230V	0,7	0,45	0,6	3,0	10,0	450

LOWER 30 - 60

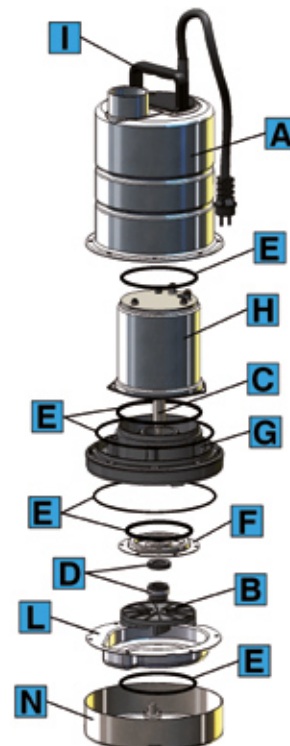

DIMENSIONI E PESI / SIZE AND WEIGHT DATA :

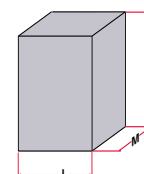
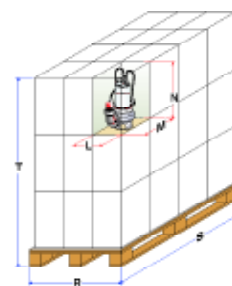
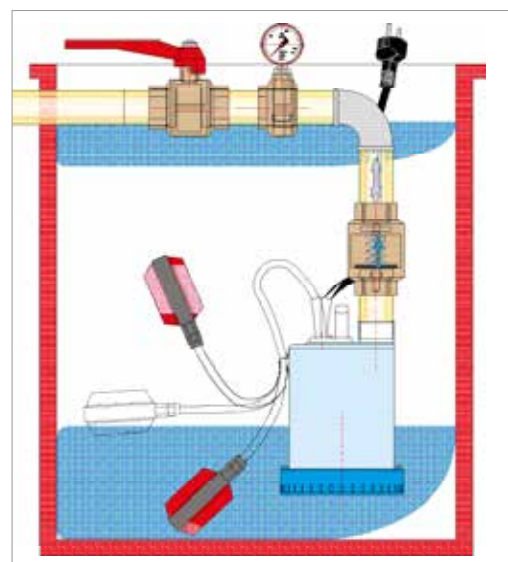
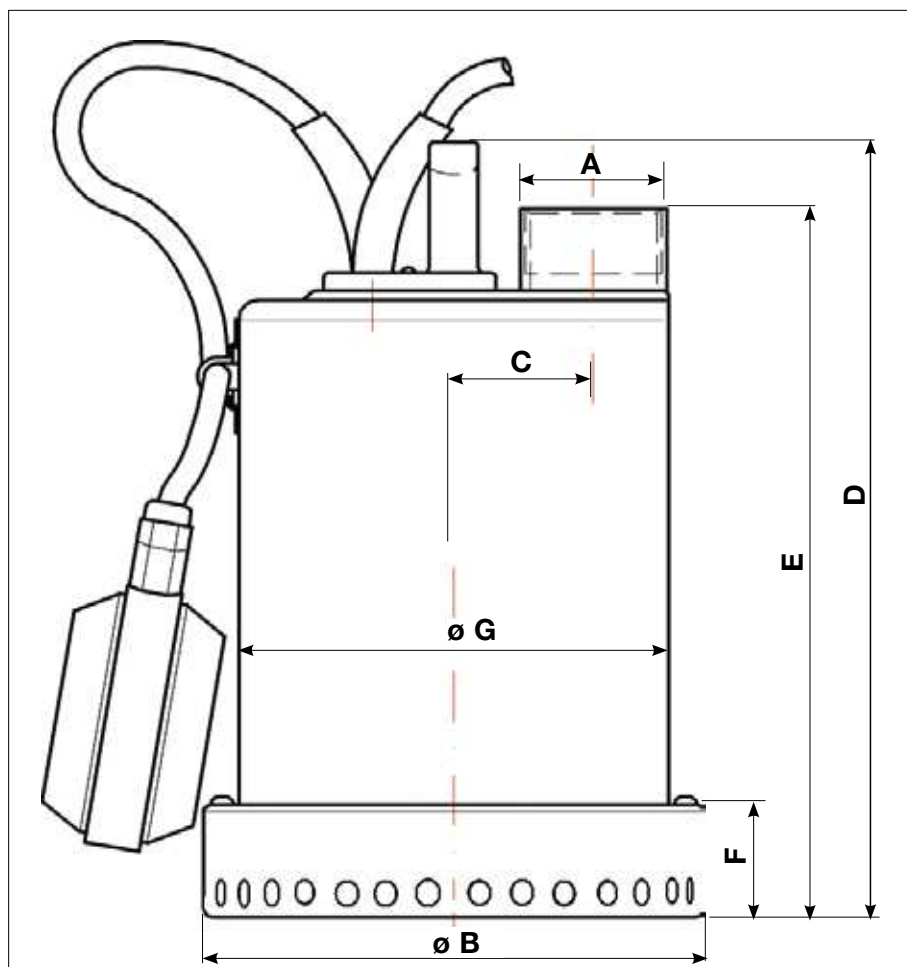

MODELLO MODEL	DIMENSIONI POMPA in mm. / PUMP DIMENSIONS in mm.						
	A	B	C	D	E	F	G
MIZAR 30	1" 1/4	154	41	249	228	50	132
MIZAR 60	1" 1/4	154	41	249	228	50	132
MIZAR 75	1" 1/4	192	41	286	266	50	132
MIZAR 60 VOX	1" 1/4	154	41	282	261	74	132
VERTICAL 30	1" 1/4	154	41	249	228	50	132
VERTICAL 60	1" 1/4	154	41	249	228	50	132
VERTICAL 60 VOX	1" 1/4	154	41	282	261	74	132
LOWER 30	1" 1/4	154	41	241	228	40	132
LOWER 60	1" 1/4	154	41	241	228	40	132

MODELLO MODEL	DIMENSIONI SCATOLA / PACKING DIMENSIONS				DIMENSIONI PALLET / PALLET DIMENSIONS				
	L mm	M mm	N mm	Peso / Weight Kg	R mm	S mm	T mm	nr. scatole/cartons	Peso / Weight Kg
MIZAR 30	220	190	330	5,5	800	1200	1465	80	450
MIZAR 60	220	190	330	6,2	800	1200	1465	80	506
MIZAR 75	220	190	330	6,7	800	1200	1465	80	536
MIZAR 60 VOX	220	190	330	6,5	800	1200	1465	80	530
MIZAR 75 VOX	220	190	330	6,7	800	1200	1465	80	536
VERTICAL 30	220	190	330	5,5	800	1200	1465	80	450
VERTICAL 60	220	190	330	6,2	800	1200	1465	80	506
VERTICAL 60 VOX	220	190	330	6,5	800	1200	1465	80	530
LOWER 30	220	190	330	5,5	800	1200	1465	80	450
LOWER 60	220	190	330	6,2	800	1200	1465	80	506

MIZAR/S aisi 316



ELETTROPOMPE SOMMERSIBILI DRENAGGIO PER ACQUE CHIARE, SPORCHE E LIQUIDI AGGRESSIVI SUBMERSIBLE ELECTRIC PUMPS FOR WHITE, DIRTY WATER AND AGGRESSIVE LIQUIDS DRAINAGE

PREVALENZA : 8,0 mt. - 10,0 mt.
PORTATA : 9,0 m³/h - 10,5 m³/h
POTENZA NOMINALE : 0,25 kW (0,33 HP) ÷ 0,45 kW (0,6 HP)
PASSAGGIO SOLIDI FINO A 10 mm (SERIE VOX 20 mm)

PUMP HEAD : 8,0 mt ÷ 10,0 mt
DELIVERY : 9,0 m³/h ÷ 10,5 m³/h
RATED HORSEPOWER : 0,25 kW (0,33 HP) ÷ 0,45 kW (0,6 HP)
SOLID MATTER BYPASS up to 10 mm (SERIE VOX 20 mm)

APPLICAZIONI

- SVUOTAMENTO DA ACQUE PIOVANE, D'INFILTRAZIONE, DI POZZETTI O VASCHE DI RACCOLTA.
- PRELIEVO DA VASCHE DI RACCOLTA DI ACQUE PIOVANE PER PICCOLE IRRIGAZIONI A SCORRIMENTO DI ORTI E DI GIARDINI.
- TRAVASO DI ACQUA CHIARA DA SERBATOI E VASCHE.
- POMPAGGIO DI ACQUE SPORCHE CON CORPI SOLIDI IN SOSPENSIONE (SOLO SERIE VOX).
- POMPAGGIO DI LIQUIDI AGGRESSIVI.

APPLICATIONS

- RAIN, SEEPAGE, SUMP PIT AND CATCH TANK WATER PUMP OUT.
- GARDEN AND VEGETABLE-GARDEN MINI FLOOD IRRIGATION SYSTEM RAINWATER CATCH TANK PUMP DOWN.
- WHITE WATER PUMP OVER FROM RESERVOIRS AND VATS.
- PUMPING DIRTY WATER WITH POSSIBLE FLOATING SOLID CONTENTS (ONLY VOX SERIES).
- PUMPING AGGRESSIVE LIQUID.



CARATTERISTICHE DI COSTRUZIONE:

- MOTORE A SECCO RAFFREDDATO DAL LIQUIDO POMPATO
- DOPPIA TENUTA MECCANICA: DOPPIO ANELLO DI TENUTA LATO MOTORE, TENUTA MECCANICA A BAGNO D'OLIO LATO POMPA
- IMMERSIONE MASSIMA: mt. 5.
- GRADO DI PROTEZIONE IP 68.
- CLASSE DI ISOLAMENTO: F
- TEMPERATURA MAX.LIQUIDO POMPATO: 35°C
- PASSAGGIO LIBERO: 10 mm MIZAR 30/S - 60/S
20 mm MIZAR 60/S VOX
- VERSIONI: Monofase:220-277V/50Hz o 220-277V/60Hz con protettore termico incorporato e condensatore permanentemente inserito.
- CAVO STANDARD:
Monofase: 10 metri H05VV-F per versione normale (aut.-man).

SPECIALI VOLTAGGI E FREQUENZE A RICHIESTA.

DESIGN ENGINEERING:

- SEMI WET MOTOR WATERCOOLED
- DOUBLE MECHANICAL SEAL: DOUBLE SEALING RING-ENGINE FACE, OIL BATH MECHANICAL SEALS PUMP FACE
- PERMISSIBLE DRAUGHT OF WATER: 5 m
- IP 68 PROTECTION CLASS.
- CLASS "F" INSULATION.
- MAX. PUMPED LIQUID TEMPERATURE: 35°C
- BY PASS SECTION: 10 mm MIZAR 30/S - 60/S
20 mm MIZAR 60/S VOX.
- VERSIONS: Single Phase: 220-277V/50 Hz or 220-277V/60Hz with built in thermal protection and permanent capacitor.
- STANDARD CABLE FEATURES:
Single phase :10 metres H05VV-F for the standard version (automatic-manual)

CUSTOMISED VOLTAGE AND FREQUENCY RATING AVAILABLE ON DEMAND.

TABELLA MATERIALI - MATERIALS TABLE:

Pos.	Componente - Component	Materiale - Materials
A	Carcassa esterna / External motor housing	ACCIAIO INOX AISI 316 - DIN 1.4401 / STAINLESS STEEL
B	Girante / Impeller	MIZAR 30/S - 60/S TECNOPOLIMERO TECNOPOLYMER
		MIZAR 60/S VOX ACCIAIO INOX AISI 316 - DIN 1.4401 / STAINLESS STEEL
C	Albero (lato pompa) / Shaft (pump side)	ACCIAIO INOX AISI 316 - DIN 1.4401 / STAINLESS STEEL
D	Tenuta meccanica / Mechanical seal	Lato pompa / Pump face CARBURO DI SILICIO - VITON SILICON CARBIDE - VITON
		Lato motore / Motor face DOPPIO ANELLO DI TENUTA DOUBLE SEALING RING
E	O-ring	VITON
F	Porta tenuta / Seal holder	ACCIAIO INOX AISI 316 - DIN 1.4401 / STAINLESS STEEL
G	Porta motore / Motor holder	TECNOPOLIMERO TECNOPOLYMER
H	Cassa motore / Motor housing	ACCIAIO INOX AISI 316 - DIN 1.4401 / STAINLESS STEEL
I	Coperchio / Cover	TECNOPOLIMERO TECNOPOLYMER
L	Diffusore / Diffuser	ACCIAIO INOX AIS 316 - DIN 1.4401 STAINLESS STEEL
N	Base d'aspirazione / Suction base	

MIZAR 30/S - 60/S

MIZAR 60/S VOX

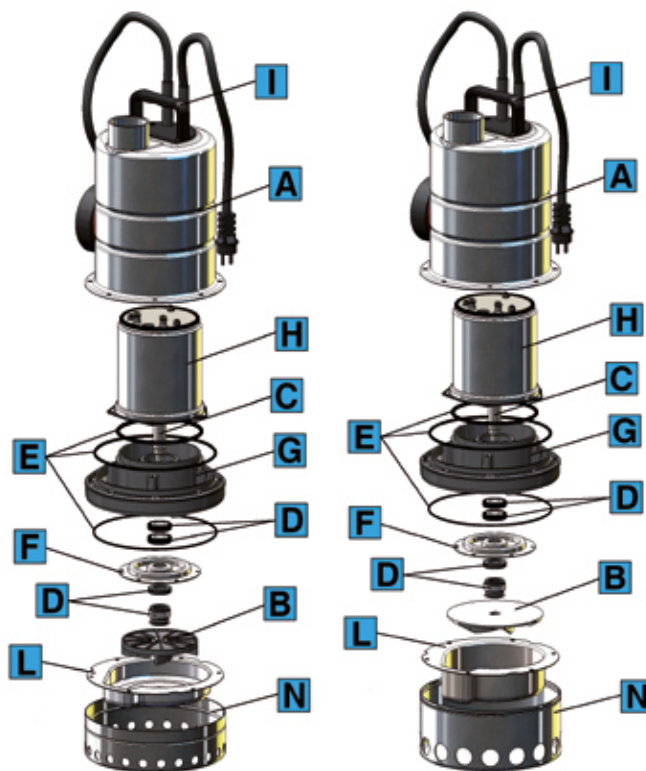

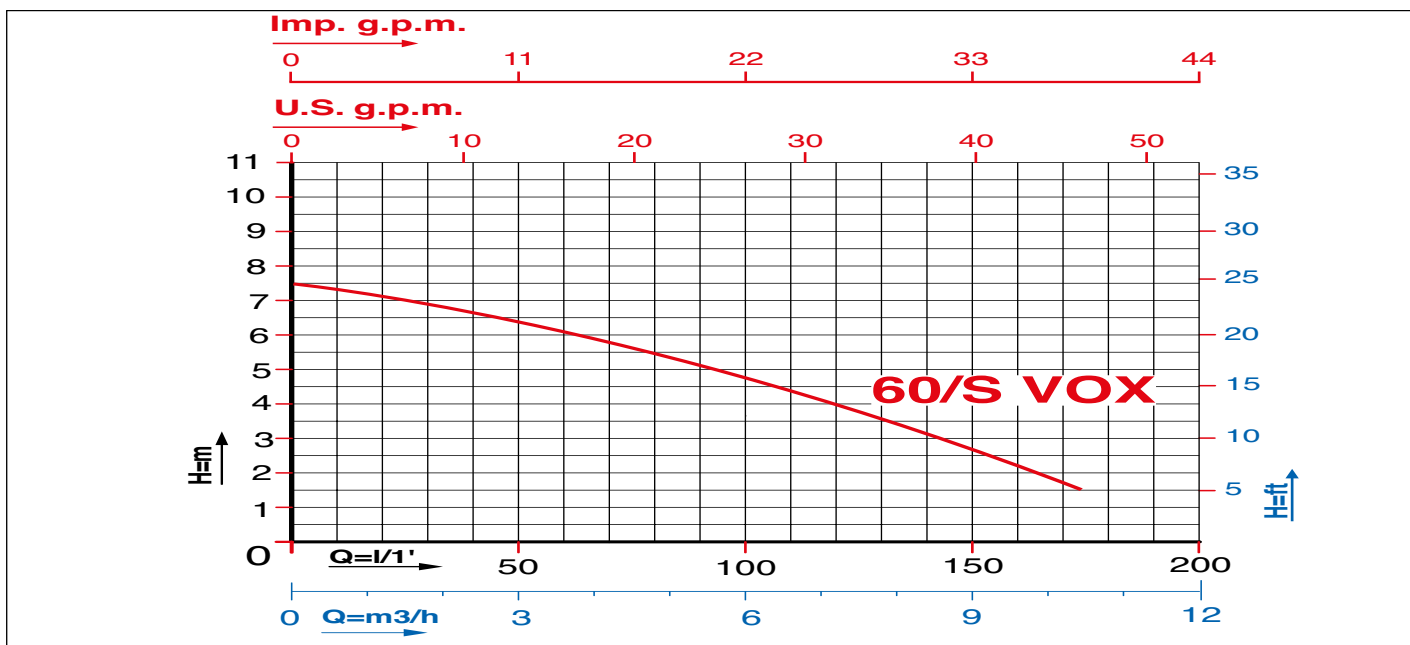
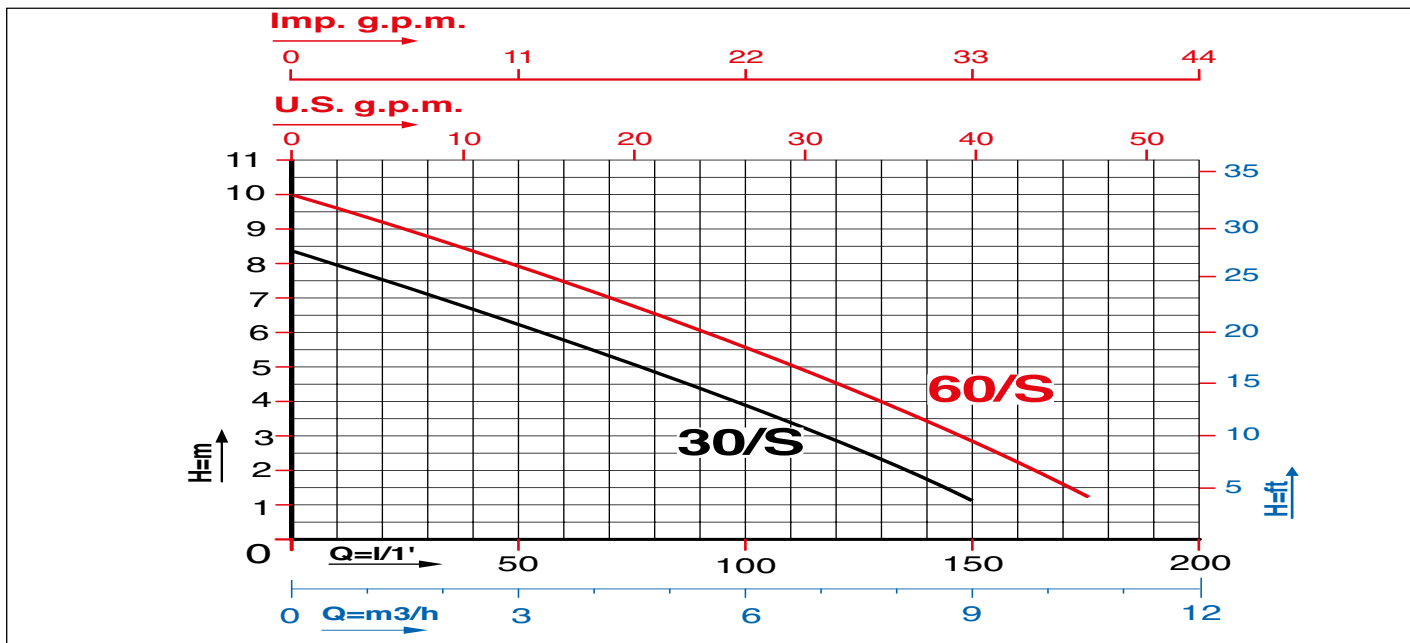

Caratteristiche di funzionamento a 2800 rpm 50Hz e 3450 rpm 60Hz - Performances at 2800 rpm 50 Hz and 3450 rpm 60 Hz
 Le prestazioni valgono per liquidi con densità $\rho = 1,0 \text{ kg/dm}^3$ ed una viscosità $\nu = 1 \text{ mm}^2/\text{s}$ / The performance data holds true for liquids with a $\rho = 1,0 \text{ kg/dm}^3$ density and a $\nu = 1 \text{ mm}^2/\text{s}$ viscosity.

MODELLO MODEL	VOLTAGGIO VOLTAGE	DATI ELETTRICI / ELECTRICAL DATA						DATI IDRAULICI / HYDRAULIC DATA								
		P1max	P2 nom.		I max	Condensatore Capacitor		m³/h	0	1,5	3	4,5	6	7,5	9	10,5
50 Hz		kW	kW	HP	Ampere	µF	VC	l/min.	0	25	50	75	100	125	150	175
MIZAR 30/S M	1 x 220-230V	0,5	0,25	0,33	2,2	8,0	450	H (m)	8,0	7,2	6,2	5,2	4,0	2,6	1,0	---
MIZAR 60/S M	1 x 220-230V	0,7	0,45	0,6	3,0	10,0	450		10,0	8,8	8,0	6,8	5,6	4,5	3,0	1,2
MIZAR 60/S T	3 x 380-440V	0,7	0,45	0,6	1,4	---	---		10,0	8,8	8,0	6,8	5,6	4,5	3,0	1,2
MIZAR 60/S VOX M	1 x 220-230V	0,6	0,45	0,6	2,8	10,0	450		7,5	7,0	6,4	5,5	4,6	3,4	2,6	1,5
MIZAR 60/S VOX T	3 x 380-440V	0,6	0,45	0,6	1,3	---	---		7,5	7,0	6,4	5,5	4,6	3,4	2,6	1,5

PREVALENZA TOTALE IN METRI COLONNIA ACQUA
TOTAL PUMP HEAD AND WATER COLUMN HEIGHT IN m.

DIMENSIONI E PESI / SIZE AND WEIGHT DATA :

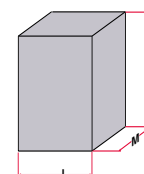
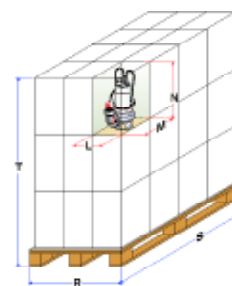
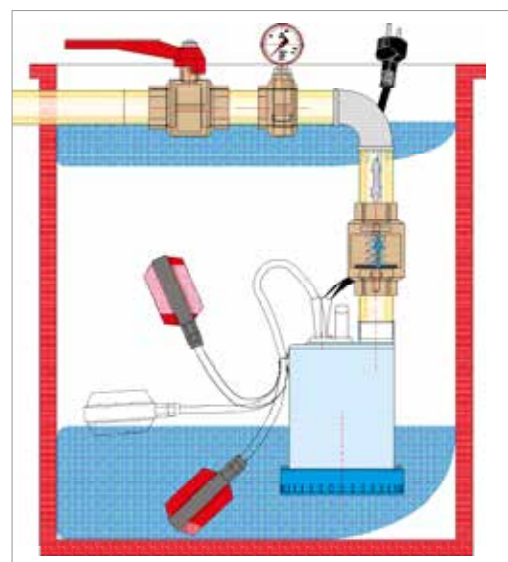
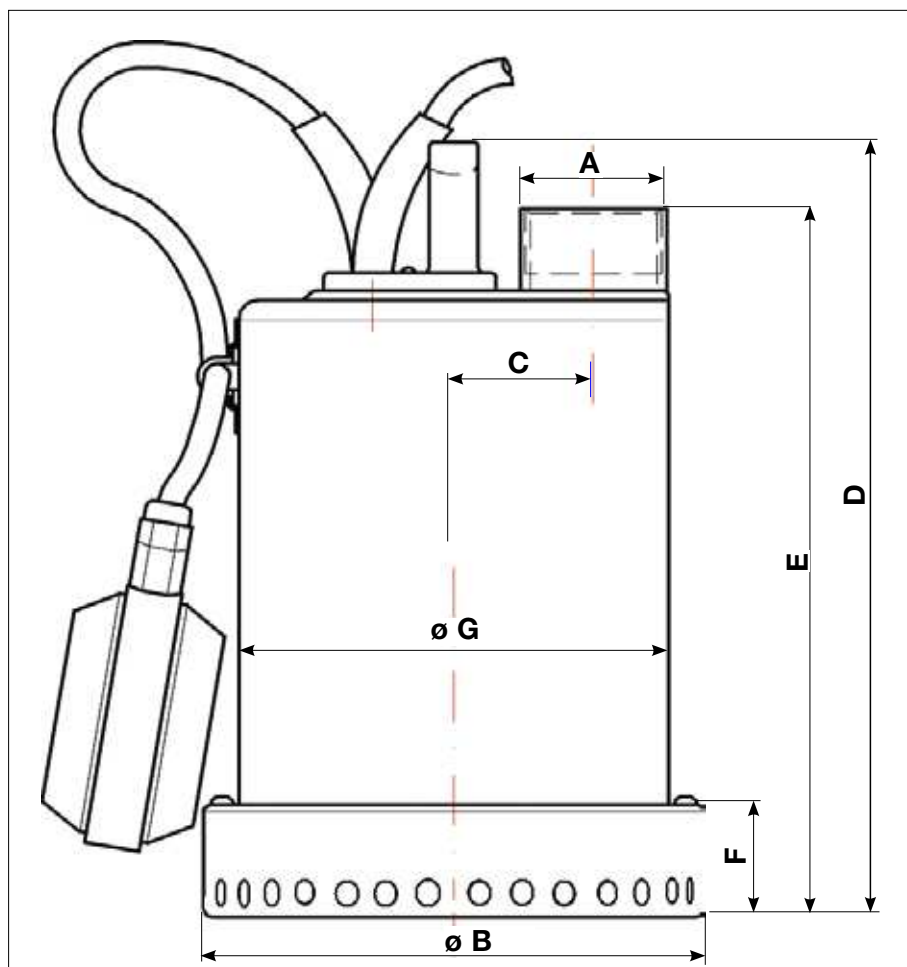

MODELLO MODEL	DIMENSIONI POMPA in mm. / PUMP DIMENSIONS in mm.						
	A	B	C	D	E	F	G
MIZAR/S 30	1" 1/4	154	41	249	228	50	132
MIZAR/S 60	1" 1/4	154	41	249	228	50	132
MIZAR/S 60 VOX	1" 1/4	154	41	282	261	74	132

MODELLO MODEL	DIMENSIONI SCATOLA / PACKING DIMENSIONS				DIMENSIONI PALLET / PALLET DIMENSIONS				
	L mm	M mm	N mm	Peso / Weight Kg	R mm	S mm	T mm	nr. scatole/cartons	Peso / Weight Kg
MIZAR 30/S	220	190	330	5,5	800	1200	1465	80	450
MIZAR 60/S	220	190	330	6,2	800	1200	1465	80	506
MIZAR 60/S VOX	220	190	330	6,5	800	1200	1465	80	530

REGAL "PROFESSIONAL"



**ELETTROPOMPE SOMMERGIBILI DRENAGGIO PER ACQUE SPORCHE E LEGGERMENTE SABBIOSE
SUBMERSIBLE ELECTRIC PUMPS FOR LIGHTLY SANDY FOUL WASTEWATER DRAINAGE**

SERVIZIO CONTINUO ALTERNATO - ALTERNATED CONTINUE SERVICE

PREVALENZA : 10,5 mt. ÷ 16,5 mt.
PORTATA : 15,0 m³/h ÷ 27,0 m³/h
POTENZA NOMINALE : 0,6 kW (0,8HP) ÷ 1,5 kW (2,2HP)
PASSAGGIO SOLIDI FINO A 10 mm.
PASSAGGIO SOLIDI FINO A 30 mm. (SERIE VOX)

PUMP HEAD : 10,5 mt ÷ 16,5 mt
DELIVERY : 15,0 m³/h ÷ 27,0 m³/h
RATED HORSEPOWER : 0,6 kW (0,8HP) ÷ 1,5 kW (2,2HP)
SOLID MATTER BYPASS up to 10 mm
SOLID MATTER BYPASS up to 30 mm (VOX SERIES)

APPLICAZIONI

- SVUOTAMENTO DI CANTINE, AUTORIMESSE, SCANTINATI
- PARTICOLARMENTE ADATTE PER CANTIERISTICA.
- SVUOTAMENTO DI PISCINE VASCHE IN GENERE E SERBATOI.
- SVUOTAMENTO DA ACQUE PIOVANE, D'INFILTRAZIONE, DI POZZETTI O VASCHE DI RACCOLTA.
- IRRIGAZIONE ORTI E GIARDINI.

APPLICATIONS

- CELLAR, GARAGE AND BASEMENT PUMP OUT.
- PARTICULARLY SUITED TO CONSTRUCTION WORK SITES
- SWIMMING POOLS, ALL SORTS OF VATS, TANKS AND RESERVOIR PUMP OUT.
- RAIN, SEEPAGE, SUMP PIT &
- GARDEN AND VEGETABLE-G

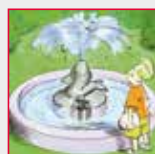

ARVEN[®]
WATER PUMPS

CARATTERISTICHE DI COSTRUZIONE:

- ELETTOPOMPA A DOPPIA CAMERA (MOTORE, TENUTA MECCANICA).
- MOTORE A BAGNO D'OLIO (BIODEGRADABILE E DIELETTRICO) PER RAFFREDDAMENTO E LUBRIFICAZIONE CUSCINETTI.
- ANELLO DI TENUTA LATO MOTORE.
- TENUTA MECCANICA A BAGNO D'OLIO
- IMMERSIONE MASSIMA: mt. 5.
- GRADO DI PROTEZIONE IP 68.
- CLASSE DI ISOLAMENTO: F
- TEMPERATURA MAX.LIQUIDO POMPATO: 35°C
- PASSAGGIO LIBERO: 10 mm. REGAL 80 - 100 - 150
30 mm. REGAL 100 VOX - 150 VOX - 200 VOX
- VERSIONI: Monofase: 220-277V/50Hz o 220-277V/60Hz con protettore termico incorporato e condensatore permanentemente inserito.
Trifase: 220-277V/50Hz o 380-480V/50Hz e 220-277V/60Hz o 380-480V/60Hz con protezione da sovraccarico a cura dell'utente.
- POTENZA MOTORE:
DA 0,6kW (0,8 Hp) a 1,1kW (1,5Hp) versioni monofase e trifase.
DA 1,5kW (2 Hp) versioni trifase.
- VERSIONI MONOFASI AUTOMATICHE CON GALLEGGIANTE O MANUALI SENZA GALLEGGIANTE
- CAVO STANDARD:
Monofase: 10 metri H07RN-F per versione normale (aut.-man).
5 metri H07RN-F solo per versione automatica.(esclusa REGAL150)
Trifase: 10 metri H07RN-F

SPECIALI VOLTAGGI E FREQUENZE A RICHIESTA.

DESIGN ENGINEERING:

- DOUBLE CHAMBER ELECTRIC PUMP (MOTOR, MECHANICAL SEAL).
- OIL BATH MOTOR (BIODEGRADABLE AND DIELECTRIC) FOR COOLING AND BEARING LUBRICATION.
- SEALING RING - ENGINE FACE.
- OIL BATH MECHANICAL SEALS.
- PERMISSIBLE DRAUGHT OF WATER: 5 m
- IP 68 PROTECTION CLASS.
- CLASS "F" INSULATION
- MAX. PUMPED LIQUID TEMPERATURE: 35°C
- BY PASS SECTION: 10 mm. REGAL 80 - 100 - 150
30 mm. REGAL 100 VOX - 150 VOX - 200 VOX
- VERSIONS: Single Phase: 220-277V/50 Hz or 220-277V/60 Hz with built in thermal protection and permanent capacitor.
Three Phase : 220-277V/50Hz or 380-480V/50Hz and 220-277V/60Hz or 380-480V/60Hz with overload protection care of the User
- MOTOR POWER:
From 0,6 kW (0,8 HP) to 1,1kW (1,5 HP) single phase and three phase versions.
From 1,5 kW (2,0 HP) three phase versions.
- AUTOMATIC SINGLE PHASE VERSIONS WITH FLOATER OR MANUAL SINGLE PHASE VERSIONS, WITHOUT FLOATER
- STANDARD CABLE FEATURES:
Single Phase: 10 metres H07RN-F for the standard version (automatic-manual)
5 metres H07RN-F only for the automatic version(excluded REGAL150)
Three Phase: 10 metres H07RN-F

CUSTOMISED VOLTAGE AND FREQUENCY RATING AVAILABLE ON DEMAND.

TABELLA MATERIALI / MATERIALS TABLE:

Pos.	Componente / Component		Materiale / Materials
A	Carcassa esterna / External motor housing		ACCIAIO INOX AISI 304 - DIN 1.4301 STAINLESS STEEL
B	Girante / Impeller		
C	Shaft (pump side)		ACCIAIO INOX AISI 316 - DIN 1.4401 STAINLESS STEEL
D	Tenuta meccanica Mechanical seal	Lato pompa / Pump side	CARBURO DI SILICIO-CERAMICA SILICON CARBIDE-CERAMIC
		Lato motore / Motor face	ANELLO DI TENUTA NBR NBR SEAL RING
E	O-ring		NBR
G	Porta motore / Motor holder		ACCIAIO INOX AISI 304 - DIN 1.4301 STAINLESS STEEL
H	Carcassa motore / Motor housing		
I	Coperchio / Cover		
L	Diffusore / Diffuser		
N	Base / Base		

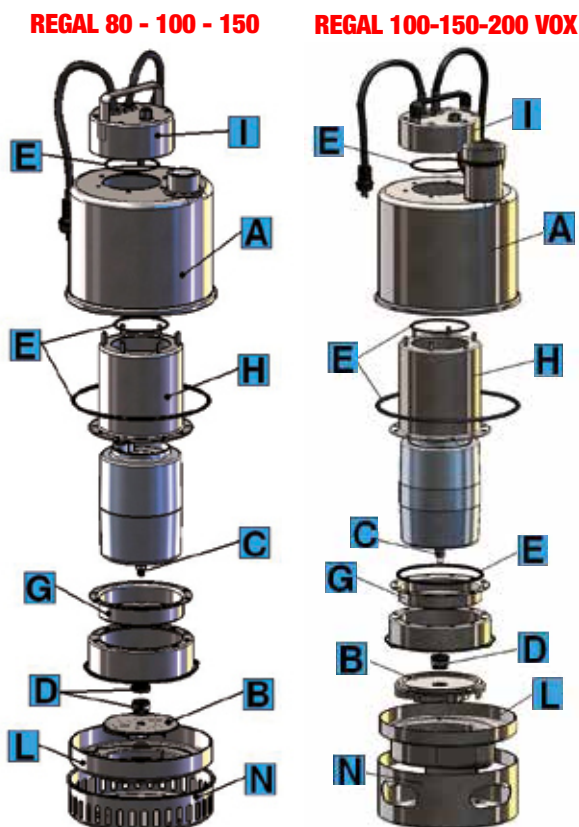

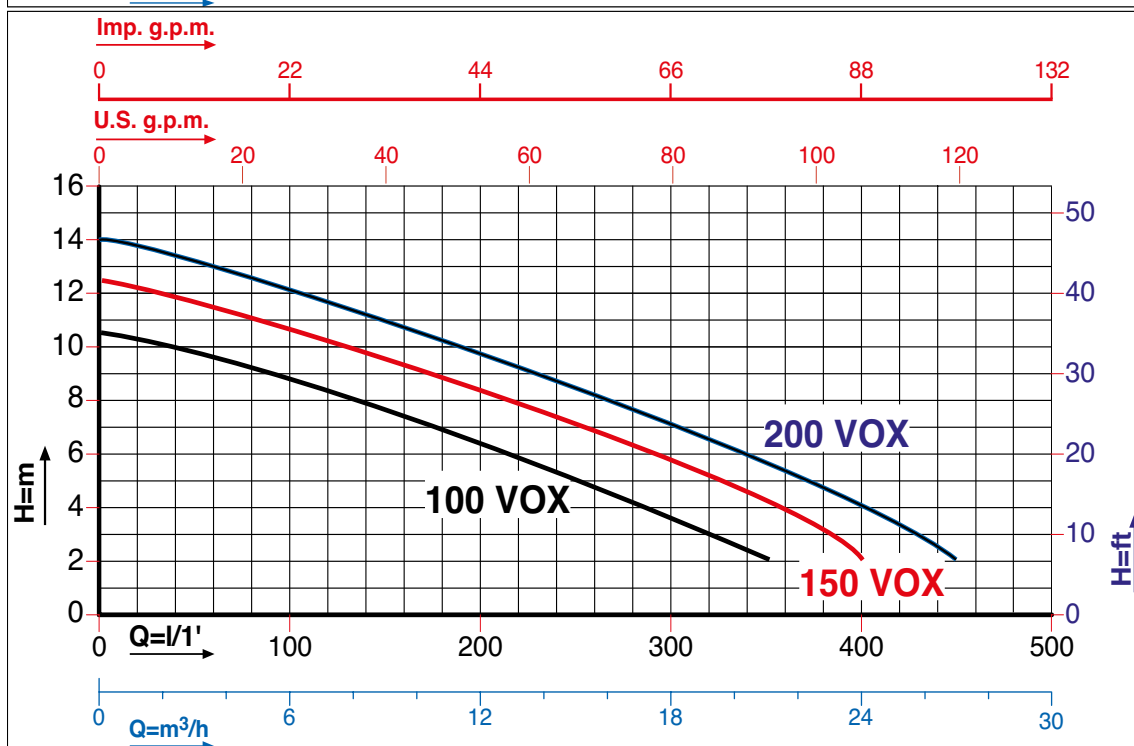
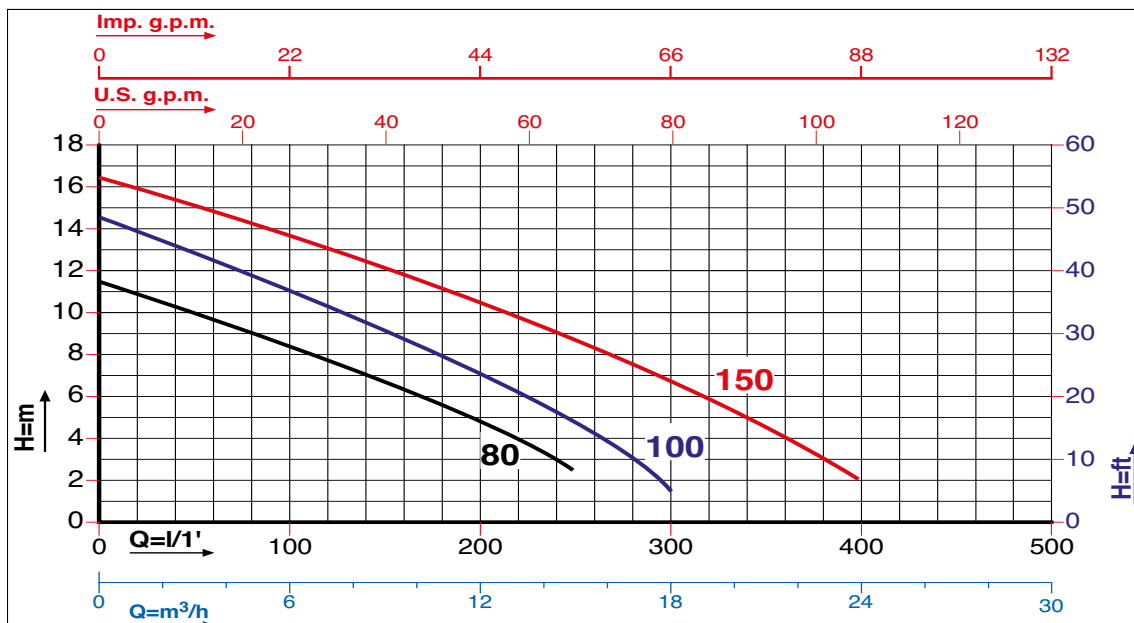

Caratteristiche di funzionamento a 2800 rpm 50Hz e 3450 rpm 60Hz - Performances at 2800 rpm 50 Hz and 3450 rpm 60 Hz
 Le prestazioni valgono per liquidi con densità $p = 1,0 \text{ kg/dm}^3$ ed una viscosità $v = 1 \text{ mm}^2/\text{s}$ / The performance data holds true for liquids with a $p = 1,0 \text{ kg/dm}^3$ density and a $v = 1 \text{ mm}^2/\text{s}$ viscosity.

MODELLO MODEL	VOLTAGGIO VOLTAGE	DATI ELETTRICI / ELECTRICAL DATA						DATI IDRAULICI / HYDRAULIC DATA									
		P1max		P2 nom.		I max	Condensatore	m³/h									
		kW	kW	HP	Ampere	µF	VC	0	3	6	9	12	15	18	21	24	27
REGAL 80 M	1 x 220-230V	1,1	0,6	0,8	4,5	16,0	450	H (m) l/min. 0 50 100 150 200 250 300 350 400 450									
REGAL 80 T	3 x 380-440V	0,9	0,6	0,8	2,1	---	---										
REGAL 100 M	1 x 220-230V	1,5	0,75	1,0	6,5	20,0	450										
REGAL 100 T	3 x 380-440V	1,3	0,75	1,0	2,2	---	---										
REGAL 150 M	1 x 220-230V	2,2	1,1	1,5	10,6	30,0	450										
REGAL 150 T	3 x 380-440V	2,0	1,1	1,5	3,3	---	---										
REGAL 100 VOX M	1 x 220-230V	1,5	0,75	1,0	6,8	20,0	450										
REGAL 100 VOX T	3 x 380-440V	1,5	0,75	1,0	2,4	---	---										
REGAL 150 VOX M	1 x 220-230V	2,2	1,1	1,5	9,0	30,0	450										
REGAL 150 VOX T	3 x 380-440V	2,0	1,1	1,5	3,3	---	---										
REGAL 200 VOX M	1 x 220-230V	2,4	1,5	2,0	10,5	30,0	450										
REGAL 200 VOX T	3 x 380-440V	2,2	1,5	2,0	3,8	---	---										

PREVALENZA TOTALE in METRI COLONNA ACQUA / TOTAL PUMP HEAD AND WATER COLUMN HEIGHT IN m.

DIMENSIONI E PESI / SIZE AND WEIGHT DATA:

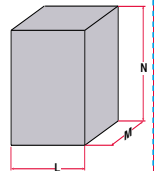
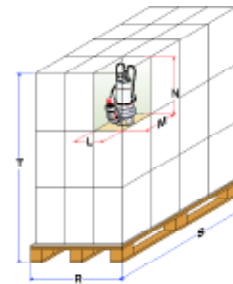
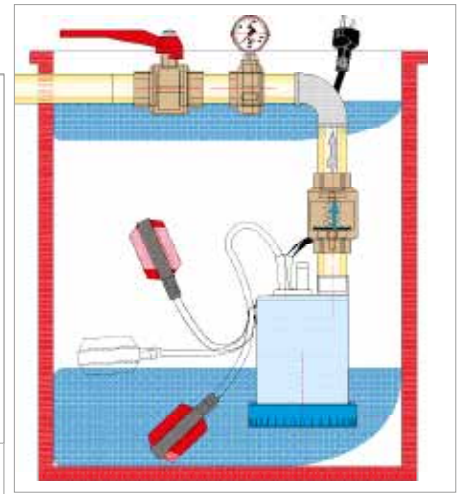
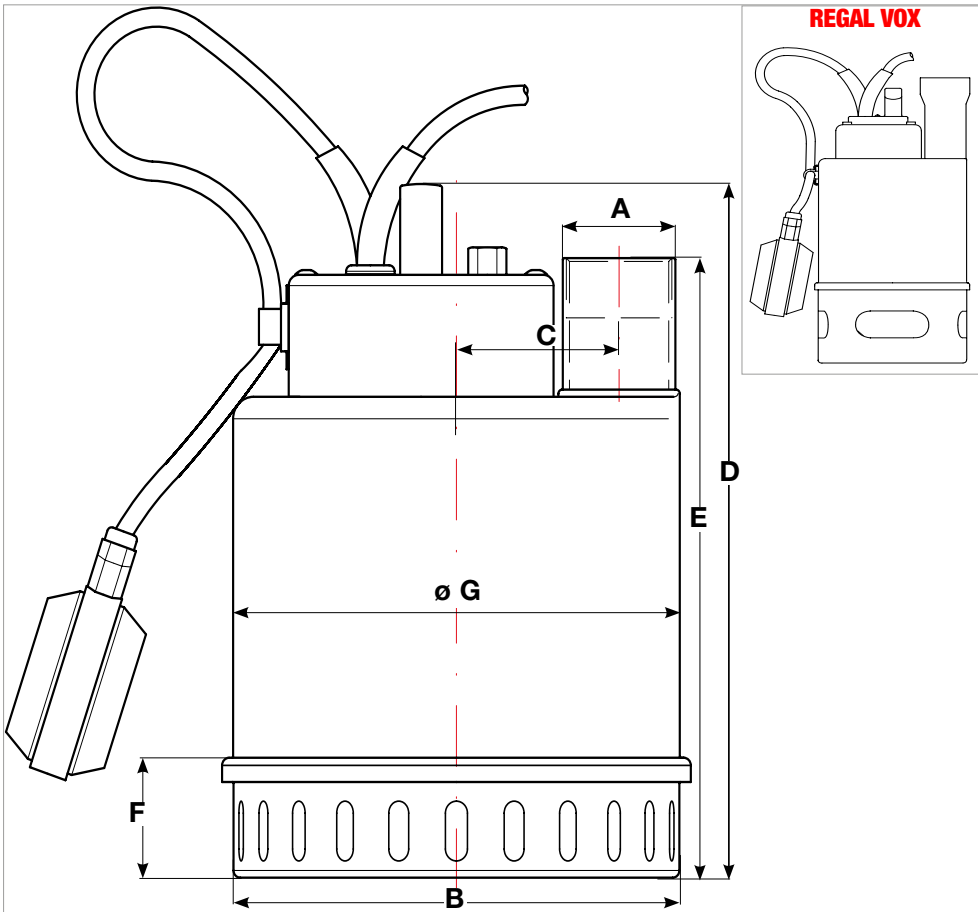

MODELLO / MODEL	DIMENSIONI POMPA in mm. / PUMP DIMENSIONS in mm.						
	A	B	C	D	E	F	G
REGAL 80	1" 1/2	212,4	73	290,2	259,2	50,5	202
REGAL 100	1" 1/2	212,4	73	290,2	259,2	50,5	202
REGAL 150	2"	212,4	73	326,7	294,7	50,5	202
REGAL 100 VOX	1 1/2"	204	73	344,2	325,2	106	202
REGAL 150 VOX	2"	204	73	384,7	393,2	106	203
REGAL 200 VOX	2"	204	73	384,7	393,2	106	203

MODELLO MODEL	DIMENSIONI SCATOLA / PACKING DIMENSIONS				DIMENSIONI PALLET / PALLET DIMENSIONS				
	L mm	M mm	N mm	Peso / Weight Kg	R mm	S mm	T mm	nr. scatole/cartons	Peso / Weight Kg
REGAL 80	220	320	340	9,0	800	1200	1400	48	447
REGAL 100	220	320	340	11,0	800	1200	1400	48	543
REGAL 150	250	290	460	18,0	800	1200	1400	36	663
REGAL 100 VOX	260	320	480	13,0	800	1200	1400	36	483
REGAL 150 VOX	260	320	480	20,0	800	1200	1400	36	735
REGAL 200 VOX	260	320	480	21,0	800	1200	1400	36	771

KONTRACT

180 - 250



ELETTROPOMPE SOMMERGIBILI DRENAGGIO PER CANTIERISTICA SUBMERSIBLE ELECTRIC PUMPS FOR CONSTRUCTION WORK SITE DRAINAGE

PREVALENZA : 17,5 mt. ÷ 18,5 mt.
PORTATA : 30 m³/h ÷ 36 m³/h
POTENZA NOMINALE : 1,1 kW (1,5HP) ÷ 1,8 kW (2,5HP)

PUMP HEAD : 17,5 mt ÷ 18,5 mt
DELIVERY : 30,0 m³/h ÷ 36,0 m³/h
RATED HORSEPOWER : 1,1 kW (1,5HP) ÷ 1,8 kW (2,5HP)

APPLICAZIONI

- DRENAGGIO DI CANTIERI EDILI E DI CUNICOLI.
- IDONEE PER IL PROSCIUGAMENTO DI SCANTINATI E BOX.
- MOVIMENTAZIONE DI ACQUE MODERATAMENTE CARICHE CONTENENTI MATERIALI ANCHE ABRASIVI, IMPIANTI DI IRRIGAZIONE, ACQUE PIOVANE E DI FALDA.

APPLICATIONS

- WORK SITE, TRENCH DUCTS AND UNDERGROUND PASSAGE PUMP OUT
- SUITED TO CELLAR, GARAGE AND BASAMENT PUMP OUT.
- HANDLING OF MODERATELY FOUL WATER WITH MATERIAL AND/OR ABRASIVE MATERIAL CONTENTS.

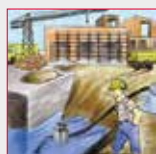

ARVEN[®]
WATER PUMPS

CARATTERISTICHE DI COSTRUZIONE:

- MOTORE A BAGNO D'OLIO (BIODEGRADABILE E DIELETRICO) PER RAFFREDDAMENTO E LUBRIFICAZIONE CUSCINETTI.
- DOPPIA TENUTA MECCANICA: LATO MOTORE A BAGNO D'OLIO. LATO POMPA A BAGNO D'ACQUA.
- IMMERSIONE MASSIMA: mt. 5.
- GRADO DI PROTEZIONE IP 68.
- CLASSE DI ISOLAMENTO: F.
- TEMPERATURA MAX. LIQUIDO POMPATO: 35°C .
- PASSAGGIO LIBERO: 10 mm.
- MONOFASE 220 - 277V/50Hz o 220 – 277V / 60 Hz:
 - con protettore termico incorporato e condensatore permanentemente inserito. (HP 1,5)
 - con protettore termico incorporato e quadro elettrico in materiale plastico completo di condensatore e interruttore. (HP 2,5)
- TRIFASE: 220-277V/50Hz o 380-480V/50Hz e 220-277V/60Hz o 380-480V/60Hz con protezione da sovraccarico a cura dell'utente.
- POTENZA MOTORE: da 1,1 kW (1,5 HP) a 1,8 kW (2,5Hp) versioni monofase e trifase.
- VERSIONI MONOFASI: automatiche con galleggiante. manuali senza galleggiante.
- CAVO STANDARD (CON GALLEGGIANTE MANUALE):
 - Monofase: 10 metri H07RN-F senza spina. (HP 1,5)
 - 10 metri H07RN-F completa di quadro elettrico con spezzone cavo 0,7 metri senza spina. (HP 2,5)
 - Trifase: 10 metri H07RN-F senza spina.

SPECIALI VOLTAGGI E FREQUENZE A RICHIESTA.

ACCESSORI DISPONIBILI A RICHIESTA:

- QUADRO ELETTRICO MONOFASE CON 2 CONDENSATORI (AVVIO/MARCIA).
- QUADRO ELETTRICO TRIFASE DI PROTEZIONE E COMANDO AUTOMATICO A MEZZO DI GALLEGGIANTE ELETTROMECCANICO .
- GALLEGGIANTE 10-20 mt. DI CAVO.
- RACCORDI E PORTA GOMMA RAPIDI DA 2" e 3" IN ALLUMINIO RAPIDO.

DESIGN ENGINEERING:

- OIL BATH MOTOR (BIODEGRADABLE AND DIELECTRIC OIL) FOR COOLING AND BEARING LUBRICATION.
- DOUBLE MECHANICAL SEALS: ENGINE FACE: OIL BATH. PUMP FACE: WATER BATH.
- PERMISSIBLE DRAUGHT OF WATER: 5 m.
- IP 68 PROTECTION CLASS.
- CLASS "F" INSULATION.
- MAX. PUMPED LIQUID TEMPERATURE: 35°C.
- BY PASS SECTION: 10 mm.
- SINGLE PHASE 220 - 277V/50Hz or 220 – 277V / 60 Hz:
 - with built in thermal protection and permanent capacitor. (HP 1,5)
 - with built in thermal protection and plastic casing power supply box comprising capacitor and switch. (HP 2,5)
- THREE PHASES: 220-277V/50 Hz or 380-480V/50Hz and 220-277V/60Hz or 380-480V/60Hz with overload protection care of the User.
- MOTOR POWER: From 1,1 kW(1,5 HP) to 1,5 kW (2,5HP)single phase and three phase versions.
- SINGLE PHASE VERSIONS: automatic version with floater. manual version without floater.
- STANDARD CABLE FEATURES (WUTH MANUAL FLOATER):
 - Single Phase: 10 metres H07RN-F without plug. (HP 1,5)
 - 10 metres H07RN-F complete with power supply box 0.7 m cable section, without connection plug. (HP 2,5)
 - Three phase: 10 metres H07RN-F without plug.

CUSTOMISED VOLTAGE AND FREQUENCY RATING AVAILABLE ON DEMAND.

ACCESSORIES AVAILABLE ON DEMAND:

- SINGLE PHASE ELECTRICAL BOX WITH 2 CAPACITORS (STARTER/RUN).
- THREE PHASES ELECTRICAL SAFETY POWER SUPPLY BOX WITH AUTOMATIC ELECTROMECHANICAL FLOATER CONTROLS.
- FLOATER CABLE: 10-20 metres.
- 2" AND 3" QUICK-UNION ALUMINIUM CONNECTORS AND RUBBER PIECE HOLDERS.

TABELLA MATERIALI / MATERIALS TABLE:

Pos.	Componente / Component	Materiale / Materials	
A	Carcassa esterna / External motor housing	ACCIAIO INOX AISI 304 - DIN 1.4301 STAINLESS STEEL	
B	Girante / Impeller	ACCIAIO INOX SPECIALE SPECIAL STAINLESS STEEL	
C	Albero (lato pompa) / Shaft (pump side)	ACCIAIO INOX AISI 316 - DIN 1.4401 / STAINLESS STEEL	
D	Doppia tenuta meccanica Double mechanical seal	Lato pompa / Pump face	CARBURO DI SILICIO-CERAMICA / SILICON CARBIDE-CERAMIC
		Lato motore / Motor face	GRAFITE-CERAMICA GRAPHITE-CERAMIC
E	O-ring	NBR	
H	Carcassa motore / Motor housing	ACCIAIO INOX AISI 304 - DIN 1.4301 / STAINLESS STEEL	
I	Coperchio / Cover	ACCIAIO INOX AISI 304 - DIN 1.4301 / STAINLESS STEEL	
L	Diffusore / Diffuser	HNBR CON ANIMA ACCIAIO HNBR WITH CORE STEEL	
N	Base aspirazione / Suction base	ACCIAIO INOX AISI 304 - DIN 1.4301 / STAINLESS STEEL	
R	Flangia inferiore / Lower flange	ALLUMINIO CON TRATTAMENTO SPECIALE ALUMINIUM WITH SPECIAL TREATMENT	

KONTRACT 180 - 250

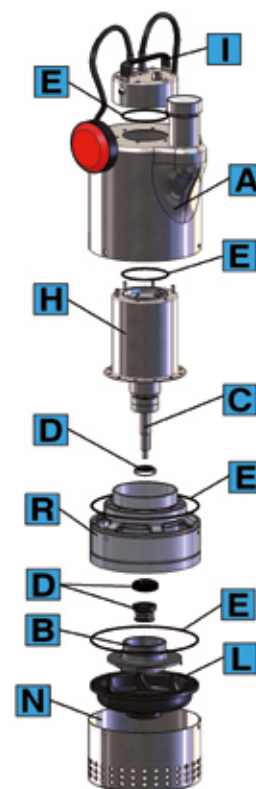

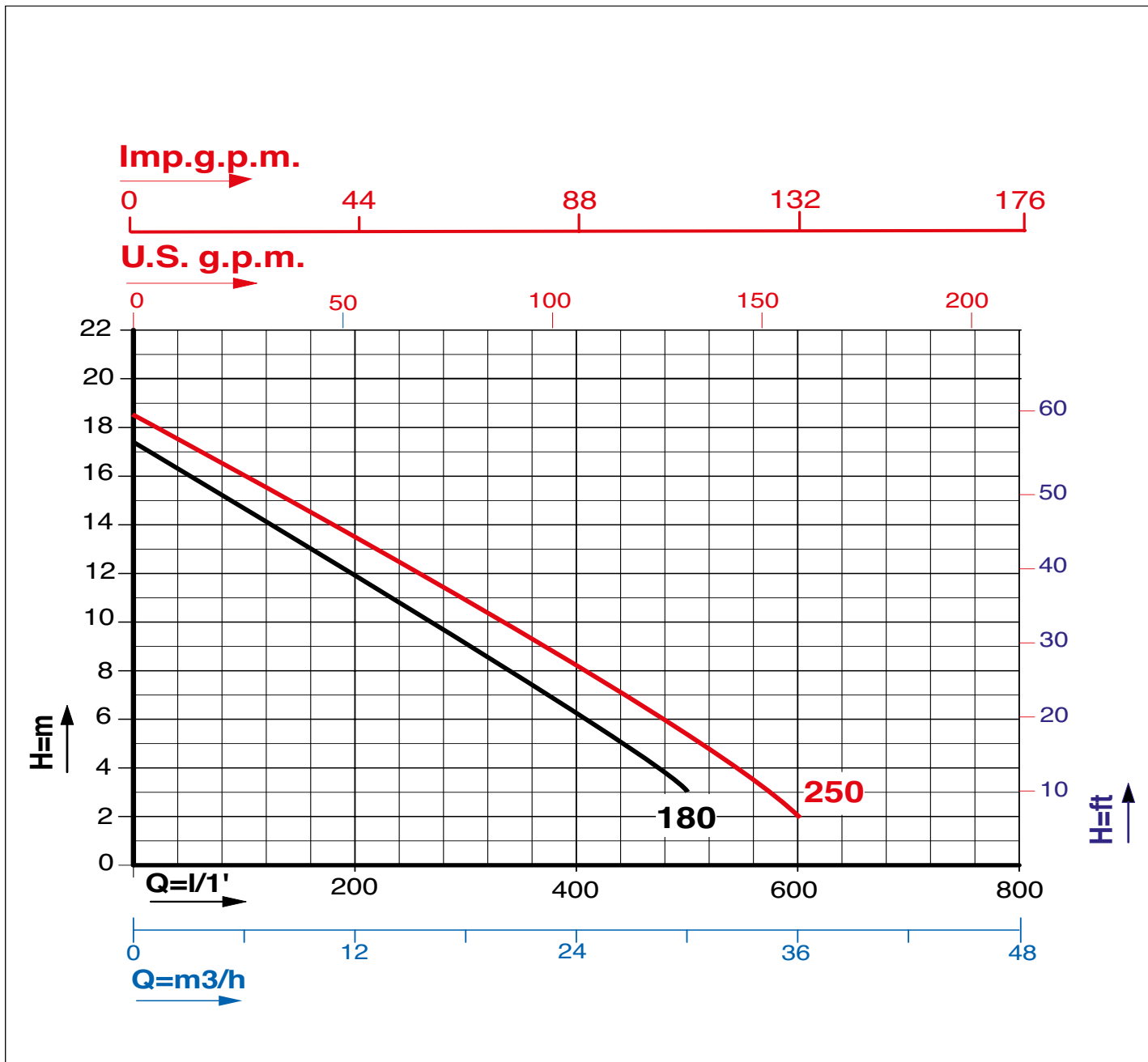

Caratteristiche di funzionamento a 2800 rpm 50Hz e 3450 rpm 60Hz - Performances at 2800 rpm 50 Hz and 3450 rpm 60 Hz

Le prestazioni valgono per liquidi con densità $\rho = 1,0 \text{ kg/dm}^3$ ed una viscosità $\nu = 1 \text{ mm}^2/\text{s}$ / The performance data holds true for liquids with a $\rho = 1,0 \text{ kg/dm}^3$ density and a $\nu = 1 \text{ mm}^2/\text{s}$ viscosity.

MODELLO MODEL	VOLTAGGIO VOLTAGE 50 Hz	DATI ELETTRICI / ELECTRICAL DATA						DATI IDRAULICI / HYDRAULIC DATA						
		P1 max kW	P2 nom. kW	I max HP	I max Ampere	Condensatore Capacitor		m³/h l/min.	0	3	12	21	3036	600
						µF	VC							
KONTRACT 180 M	1 x 220-230V	2,2	1,1	1,5	9,5	30,0	450	H (m)	17,5	16,0	12,0	8,0	3,0	
KONTRACT 180 T	3 x 380-400V	2,0	1,1	1,5	3,3	---	---		17,5	16,0	12,0	8,0	3,0	
KONTRACT 250 M	1 x 220-230V	3,0	1,8	2,5	13,5	40,0	450		18,5	17,0	14,0	9,5	5,0	2,0
KONTRACT 250 T	3 x 380-400V	2,8	1,8	2,5	4,6	---	---		18,5	17,0	14,0	9,5	5,0	2,0

PREVALENZA TOTALE IN METRI
COLONNA ACQUA / TOTAL PUMP HEAD AND
WATER COLUMN HEIGHT IN FT.

DIMENSIONI E PESI / SIZE AND WEIGHT DATA:

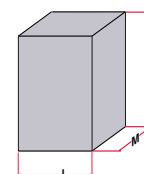
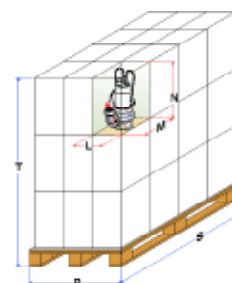
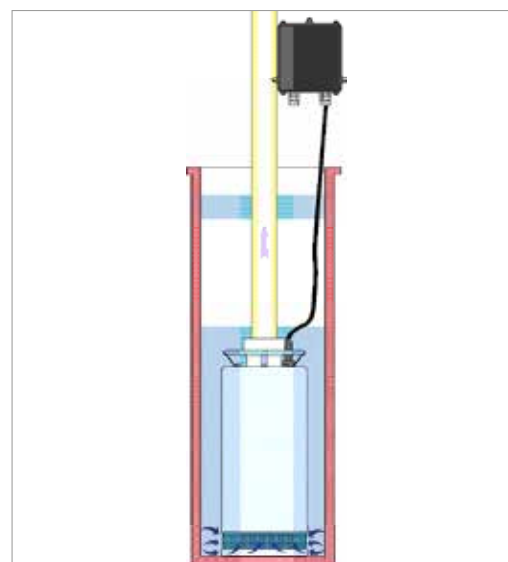
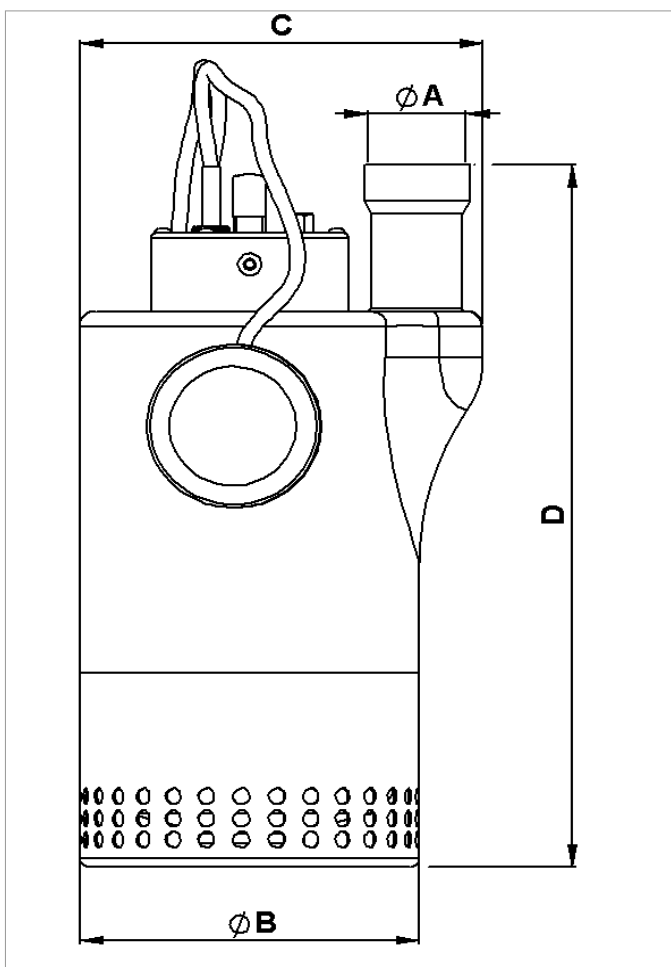

MODELLO / MODEL	DIMENSIONI POMPA in mm. / PUMP DIMENSIONS in mm.			
	A	B	C	D
KONTRACT 180 M	2"	203	230	446
KONTRACT 180 T	2"	203	230	446
KONTRACT 250 M	2"	203	230	446
KONTRACT 250 T	2"	203	230	446

MODELLO / MODEL	DIMENSIONI SCATOLA / PACKING DIMENSIONS				DIMENSIONI PALLET / PALLET DIMENSIONS				
	L mm.	M mm.	N mm.	Peso / Weight Kg.	R mm.	S mm.	T mm.	nr. scatole/cartons	Peso / Weight Kg.
KONTRACT 180 M	650	370	260	21,0	800	1200	1450	20	420
KONTRACT 180 T	650	370	260	21,0	800	1200	1450	20	420
KONTRACT 250 M	650	370	260	25,0	800	1200	1450	20	500
KONTRACT 250 T	650	370	260	25,0	800	1200	1450	20	500

KONTRACT

300 - 400 - 600



ELETTROPOMPE SOMMERGIBILI DRENAGGIO PER CANTIERISTICA **SUBMERSIBLE ELECTRIC PUMPS FOR CONSTRUCTION WORK SITE DRAINAGE**

PREVALENZA : 20,0 mt. ÷ 23,0 mt.
PORTATA : 54,0 m³/h ÷ 84,0 m³/h
POTENZA NOMINALE : 2,25 kW (3HP) ÷ 4,5 kW (6HP)

PUMP HEAD : 20,0 mt ÷ 23,0 mt
DELIVERY : 54,0 m³/h ÷ 84,0 m³/h
RATED HORSEPOWER : 2,25 kW (3,0HP) ÷ 4,5 kW (6,0HP)

APPLICAZIONI

- DRENAGGIO DI CANTIERI EDILI E DI CUNICOLI.
- IDONEE PER IL PROSCIUGAMENTO DI SCANTINATI E BOX.
- MOVIMENTAZIONE DI ACQUE MODERATAMENTE CARICHE CONTENENTI MATERIALI ANCHE ABRASIVI, IMPIANTI DI IRRIGAZIONE, ACQUE PIOVANE E DI FALDA.

APPLICATIONS

- WORK SITE, TRENCH DUCTS AND UNDERGROUND PASSAGE PUMP OUT.
- SUITED TO CELLAR, GARAGE AND BASEMENT PUMP OUT.
- HANDLING OF MODERATELY FOUL WATER WITH MATERIAL AND/OR ABRASIVE MATERIAL CONTENTS.

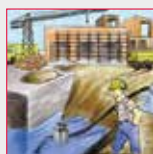

ARVEN[®]
WATER ■ PUMPS

CARATTERISTICHE DI COSTRUZIONE:

- MOTORE A BAGNO D'OLIO (BIODEGRADABILE E DIELETTRICO) PER RAFFREDDAMENTO E LUBRIFICAZIONE CUSCINETTI.
- DOPPIA TENUTA MECCANICA: LATO MOTORE A BAGNO D'OLIO. LATO POMPA A BAGNO D'ACQUA.
- IMMERSIONE MASSIMA: mt. 5.
- GRADO DI PROTEZIONE IP 68.
- CLASSE DI ISOLAMENTO: F.
- TEMPERATURA MAX. LIQUIDO POMPATO: 35°C .
- PASSAGGIO LIBERO: 10 mm.
- MONOFASE 220 - 277V/50Hz o 220 – 277V / 60 Hz, con protettore termico incorporato e quadro elettrico in materiale plastico completo di condensatore e interruttore.
- TRIFASE 220-277V/50Hz o 380-480V/50Hz e 220-277V/60Hz o 380-480V/60Hz con protezione da sovraccarico a cura dell'utente.
- POTENZA MOTORE:
da 2,25 kW (3,0 Hp) versioni monofase e trifase.
da 3,0 kW (4,0 HP) a 4,5kW (6,0 HP) solo versione trifase.
- VERSIONI MONOFASI MANUALI (senza galleggiante).
- CAVO STANDARD:
Monofase: 10 metri H07RN-F completa di quadro elettrico con spezzone cavo 0,7 metri senza spina.
Trifase: 10 metri H07RN-F senza spina.

SPECIALI VOLTAGGI E FREQUENZE A RICHIESTA.

ACCESSORI DISPONIBILI A RICHIESTA:

- QUADRO ELETTRICO MONOFASE CON 2 CONDENSATORI (AVVIO/MARCIA).
- QUADRO ELETTRICO MONOFASE E TRIFASE DI PROTEZIONE E COMANDO AUTOMATICO A MEZZO DI GALLEGGIANTE ELETTROMECCANICO.
- GALLEGGIANTE 10-20 mt. DI CAVO.
- RACCORDI E PORTA GOMMA RAPIDI DA 2" e 3" IN ALLUMINIO RAPIDO.

DESIGN ENGINEERING:

- OIL BATH MOTOR (BIODEGRADABLE AND DIELECTRIC OIL) FOR COOLING AND BEARING LUBRICATION.
- DOUBLE MECHANICAL SEALS: ENGINE FACE: OIL BATH. PUMP FACE: WATER BATH.
- PERMISSIBLE DRAUGHT OF WATER: 5 m.
- IP 68 PROTECTION CLASS.
- CLASS "F" INSULATION.
- MAX. PUMPED LIQUID TEMPERATURE: 35°C.
- BY PASS SECTION: 10 mm.
- SINGLE PHASE 220 - 277V/50Hz or 220 – 277V / 60 Hz, with built in thermal protection and plastic casing power supply box comprising capacitor and switch.
- THREE PHASES: 220-277V/50 Hz or 380-480V/50Hz and 220-277V/60Hz or 380-480V/60Hz with overload protection care of the User.
- MOTOR POWER:
From 2,25 kW (3,0 HP) single phase and three phases versions.
From 3,0 kW (4,0 HP) to 4,5 kW (6,0 HP) only three phases version.
- SINGLE PHASE VERSIONS only manual (without floater).
- STANDARD CABLE FEATURES:
Single Phase: 10 metres H07RN-F complete with power supply box 0.7 m cable section, without connection plug.
Three phases: 10 metres H07RN-F without plug.

CUSTOMISED VOLTAGE AND FREQUENCY RATING AVAILABLE ON DEMAND.

ACCESSORIES AVAILABLE ON DEMAND:

- SINGLE PHASE ELECTRICAL BOX WITH 2 CAPACITORS (STARTER/RUN).
- SINGLE PHASE AND THREE PHASE ELECTRICAL SAFETY POWER SUPPLY BOX WITH AUTOMATIC ELECTROMECHANICAL FLOATER CONTROLS.
- FLOATER CABLE: 10-20 metres.
- 2" AND 3" QUICK-UNION ALUMINIUM CONNECTORS AND RUBBER PIECE HOLDERS.

TABELLA MATERIALI / MATERIALS TABLE:

Pos.	Componente / Component	Materiale / Materials
A	Carcassa esterna / External motor housing	ACCIAIO INOX AISI 304 - DIN 1.4301 STAINLESS STEEL
B	Girante / Impeller	ACCIAIO INOX SPECIALE SPECIAL STAINLESS STEEL
C	Albero (lato pompa) / Shaft (pump side)	ACCIAIO INOX AISI 316 - DIN 1.4401 / STAINLESS STEEL
D	Doppia tenuta meccanica Double mechanical seal	Lato pompa / Pump face CARBURO DI SILICIO-CARBURO DI SILICIO / SILICON CARBIDE-SILICON CARBIDE
		Lato motore / Motor face GRAFITE-CERAMICA GRAPHITE-CERAMIC
E	O-ring	NBR
H	Carcassa motore / Motor housing	ACCIAIO INOX AISI 304 - DIN 1.4301 / STAINLESS STEEL
I	Coperchio / Cover	GHISA (G20) CAST IRON
L	Diffusore / Diffuser	HNBR CON ANIMA ACCIAIO HNBR WITH CORE STEEL
N	Base aspirazione / Suction base	ACCIAIO INOX AISI 304 - DIN 1.4301 / STAINLESS STEEL
R	Flangia inferiore / Lower flange	GHISA (G20) CAST IRON
S	Flangia superiore / Upper flange	

KONTRACT 300 - 400 - 600

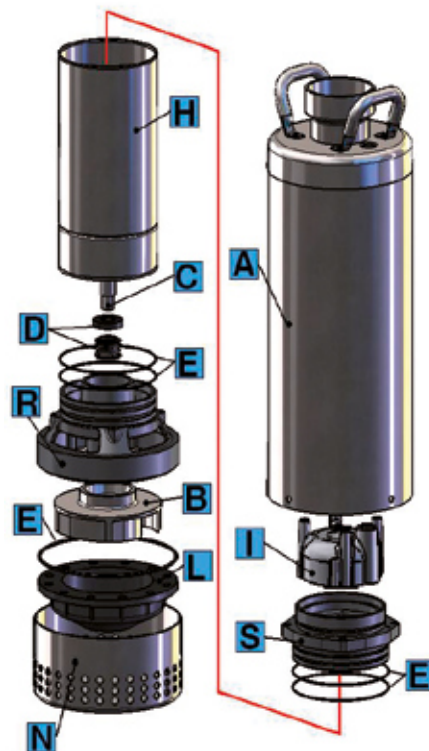

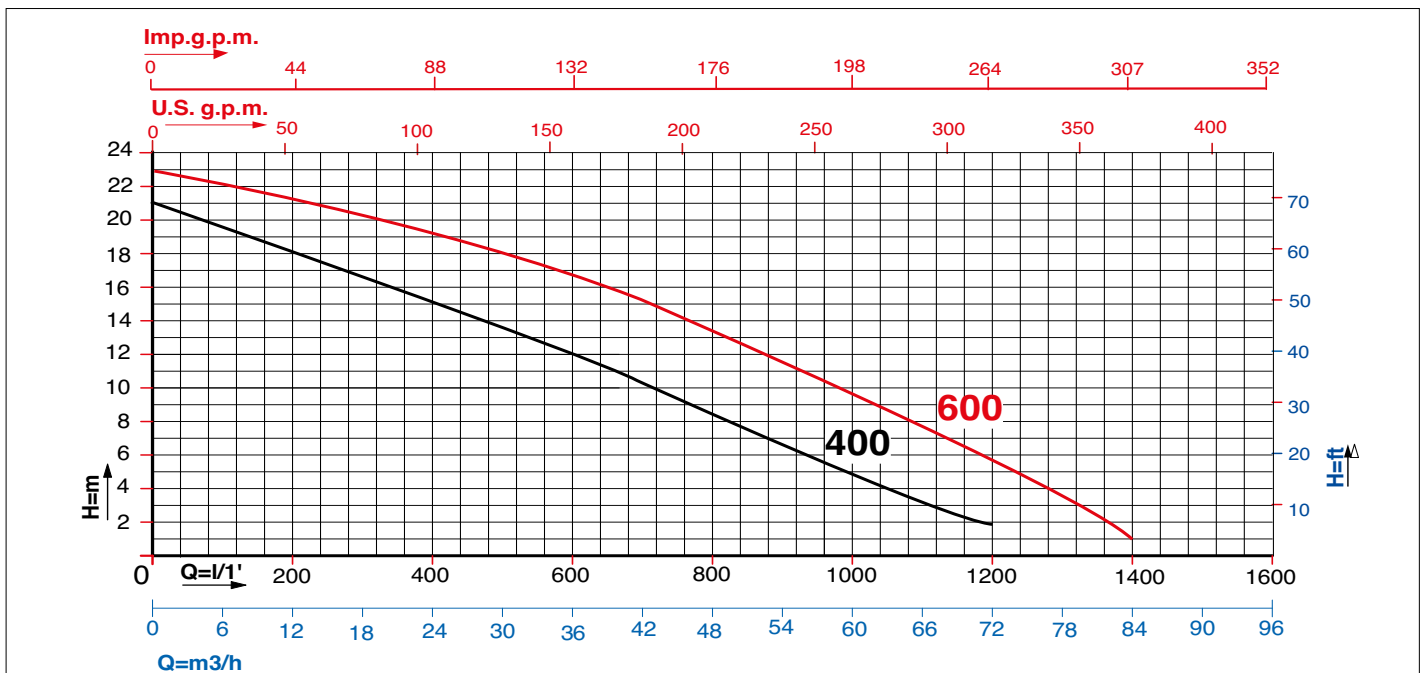
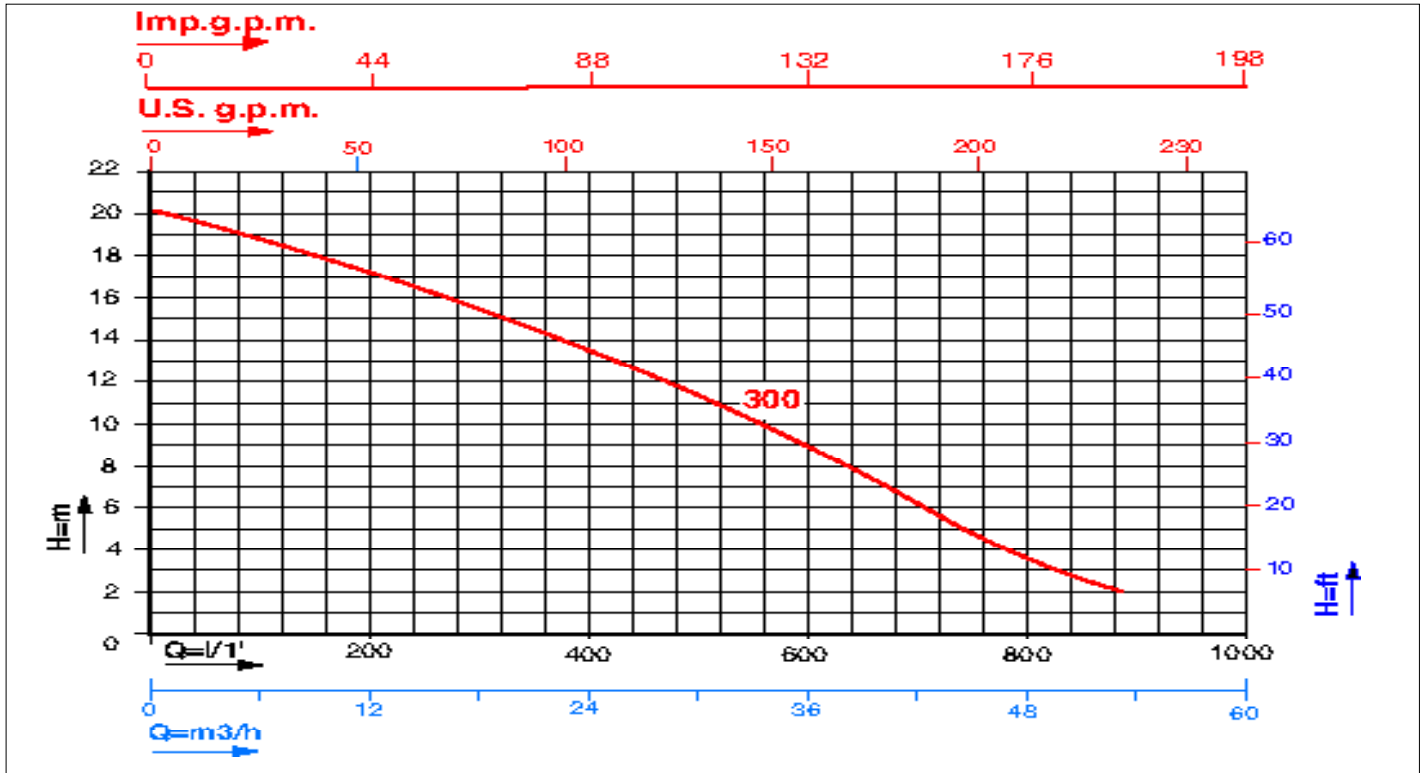

Caratteristiche di funzionamento a 2800 rpm 50Hz e 3450 rpm 60Hz - Performances at 2800 rpm 50 Hz and 3450 rpm 60 Hz

Le prestazioni valgono per liquidi con densità $\rho = 1,0 \text{ kg/dm}^3$ ed una viscosità $\nu = 1 \text{ mm}^2/\text{s}$ / The performance data holds true for liquids with a $\rho = 1,0 \text{ kg/dm}^3$ density and a $\nu = 1 \text{ mm}^2/\text{s}$ viscosity.

MODELLO MODEL	VOLTAGGIO VOLTAGE 50 Hz	DATI ELETTRICI / ELECTRICAL DATA						DATI IDRAULICI / HYDRAULIC DATA									
		P1 max		P2 nom.		I max	Condensatore Capacitor		m^3/h	0	3	12	21	30	42	54	72
		kW	kW	HP	Ampere	μF	VC	$l/min.$	0	50	200	350	500	700	900	1200	1400
KONTRACT 300 M	1 x 220-230V	4,0	2,25	3,0	20,0	80,0	450	H (m)	20,0	18,5	17,0	14,5	11,5	6,0	2,0	---	---
KONTRACT 300 T	3 x 380-440V	3,7	2,25	3,0	6,5	---	---		20,0	18,5	17,0	14,5	11,5	6,0	2,0	---	---
KONTRACT 400 T	3 x 380-440V	5,0	3,0	4,0	9,5	---	---		21,0	20,0	18,0	16,0	13,5	10,5	6,5	2,0	---
KONTRACT 600 T	3 x 380-440V	7,0	4,5	6,0	13,0	---	---		23,0	22,5	21,5	19,5	18,0	15,2	11,8	5,8	1,0

PREVALENZA TOTALE in METRI COLONNA ACQUA / TOTAL PUMP HEAD AND WATER COLUMN HEIGHT IN m.

DIMENSIONI E PESI / SIZE AND WEIGHT DATA:

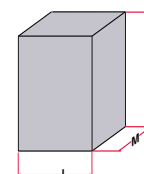
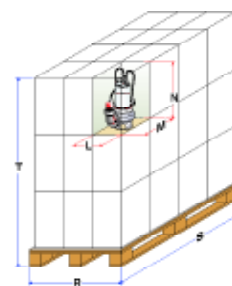
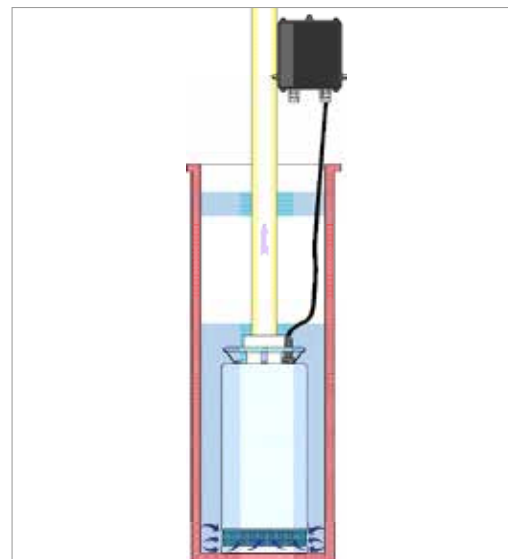
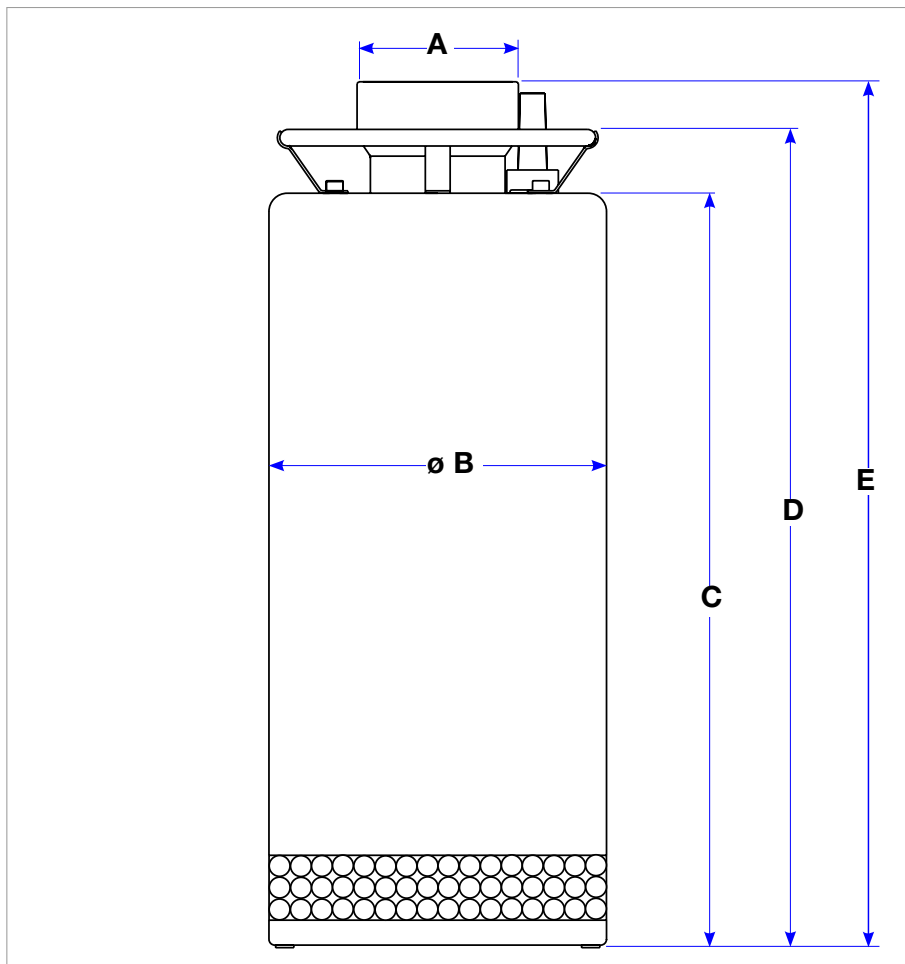

MODELLO / MODEL	DIMENSIONI POMPA in mm. / PUMP DIMENSIONS in mm.				
	A	B	C	D	E
KONTRACT 300 M	3"	203	484	539	551
KONTRACT 300 T	3"	203	484	539	551
KONTRACT 400 T	3"	203	484	539	551
KONTRACT 600 T	3"	203	484	539	551

MODELLO / MODEL	DIMENSIONI SCATOLA / PACKING DIMENSIONS				DIMENSIONI PALLET / PALLET DIMENSIONS				
	L mm.	M mm.	N mm.	Peso / Weight Kg.	R mm.	S mm.	T mm.	nr. scatole/cartons	Peso / Weight Kg.
KONTRACT 300 M	580	400	260	38,0	800	1200	900	12	481
KONTRACT 300 T	580	400	260	38,0	800	1200	900	12	481
KONTRACT 400 T	580	400	260	38,0	800	1200	900	12	481
KONTRACT 600 T	580	400	260	43,0	800	1200	900	12	541

KONTRACT

550 - 750 - 1250 - 1500



ELETTROPOMPE SOMMERSIBILI DRENAGGIO PER CANTIERISTICA SUBMERSIBLE ELECTRIC PUMPS FOR CONSTRUCTION WORK SITE DRAINAGE

PREVALENZA : 34 mt. ÷ 45 mt.
PORTATA : 72 m³/h ÷ 120 m³/h
POTENZA NOMINALE : 5,5 kW (7,5 HP) ÷ 15 kW (20 HP)

PUMP HEAD : 34 mt ÷ 45 mt
DELIVERY : 72 m³/h ÷ 120m³/h
RATED HORSEPOWER : 5,5 kW (7,5 HP) ÷ 15 kW (20 HP)

APPLICAZIONI

- DRENAGGIO DI CANTIERI EDILI E DI CUNICOLI.
- IDONEE PER IL PROSCIUGAMENTO DI SCANTINATI E BOX.
- MOVIMENTAZIONE DI ACQUE MODERATAMENTE CARICHE CONTENENTI MATERIALI ANCHE ABRASIVI, IMPIANTI DI IRRIGAZIONE, ACQUE PIOVANE E DI FALDA.

APPLICATIONS

- WORK SITE, TRENCH DUCTS AND UNDERGROUND PASSAGE PUMP OUT.
- SUITED TO CELLAR, GARAGE AND BASEMENT PUMP OUT.
- HANDLING OF MODERATELY FOUL WATER WITH MATERIAL AND/OR ABRASIVE MATERIAL CONTENTS.

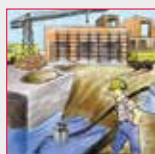

ARVEN[®]
WATER PUMPS

CARATTERISTICHE DI COSTRUZIONE:

- MOTORE A DOPPIO ISOLAMENTO
 - DOPPIA TENUTA MECCANICA IN BAGNO D'OLIO.
 - IMMERSIONE MASSIMA: mt. 5 - 20.
 - GRADO DI PROTEZIONE IP 68.
 - CLASSE DI ISOLAMENTO: H.
 - TEMPERATURA MASSIMA LIQUIDO ASPIRATO: 35°C.
 - PASSAGGIO LIBERO: 10 mm.
 - TRIFASE 220-230V/50Hz o 380-400V/50Hz e 220-230V/60Hz o 380-400V/60Hz.
 - POTENZA MOTORE:
da 5,5 kW (7,5 Hp) a 15,0 kW (20 Hp) trifase.
 - CAVO STANDARD:
Trifase: 10 metri H07RN-F senza spina.
 - PROTEZIONE AMPEROMETRICA INTERNA INDIPENDENTE
- SPECIALI VOLTAGGI E FREQUENZE A RICHIESTA.

ACCESSORI DISPONIBILI A RICHIESTA:

- SENSORE TERMICO PER TEMPERATURA MOTORE E SENSORE DI PRESENZA ACQUA.
- QUADRO ELETTRICO TRIFASE DI PROTEZIONE E COMANDO AUTOMATICO A MEZZO DI GALLEGGIANTE CON PROTEZIONE TERMICA SULL'AVVOLGIMENTO E MONITORAGGIO INFILTRAZIONE D'ACQUA
- GALLEGGIANTE 10-20 mt. DI CAVO.
- SENSORI DI LIVELLO

DESIGN ENGINEERING:

- ENGINE WITH DOUBLE INSULATION
 - DOUBLE MECHANICAL SEALS IN OIL BATH
 - PERMISSIBLE DRAUGHT OF WATER: 5 m - 20.
 - IP 68 PROTECTION CLASS.
 - CLASS "F" INSULATION.
 - MAX. PUMPED LIQUID TEMPERATURE: 35°C.
 - BY PASS SECTION: 10 mm.
 - THREE PHASES: 220-277V/50 Hz or 380-480V/50Hz and 220-277V/60Hz or 380-480V/60Hz with overload protection care of the User.
 - MOTOR POWER:
From 5,5 kW (7,5 HP) to 15,0 kW (20,0 HP) only three phases version.
 - STANDARD CABLE FEATURES:
Three phases: 10 metres H07RN-F without plug.
 - INDIPENDENT INTERNAL AMPEROMETRIC PROTECTION
- CUSTOMISED VOLTAGE AND FREQUENCY RATING AVAILABLE ON DEMAND.

ACCESSORIES AVAILABLE ON DEMAND:

- THERMAL SENSOR FOR TEMPERATURE AND WATER SENSOR IN MECHANICAL SEALS CHAMBER.
- THREE PHASE ELECTRICAL SAFETY POWER SUPPLY BOX WITH AUTOMATIC FLOATER CONTROLS AND SENSOR (WATER INFILTRATION)
- FLOATER: 10-20 METERS CABLE.
- LEVEL SENSOR

TABELLA MATERIALI / MATERIALS TABLE:

Pos.	Componente / Component	Materiale / Materials	
A	Carcassa esterna / External motor housing	ACCIAIO INOX AISI 304 - DIN 1.4301	
B	Girante / Impeller	GHISA (GJS 400) CON TRATTAMENTO	
C	Albero (lato pompa) / Shaft (pump side)	ACCIAIO INOX AISI 316 - DIN 1.4401 /	
D	Doppia tenuta meccanica in bagno d'olio Double mechanical seal in oil bath	Lato pompa / Pump face	CABELLO DISLUCCO-CABELLO DISLUCCO
		Lato motore / Motor face	GRAFITE-CERAMICA
E	O-ring	NBR	
H	Carcassa motore / Motor housing	ACCIAIO INOX AISI 304 - DIN 1.4301 /	
I	Coperchio / Cover	GHISA (G20)	
L	Diffusore con HNBR / Diffuser with HNBR rubber	GHISA CON HNBR CAST IRON WITH HNBR	
N	Base aspirazione / Suction base	ACCIAIO INOX AISI 304 - DIN 1.4301 /	
R	Flangia inferiore / Lower flange	GHISA (G25)	
S	Flangia superiore / Upper flange	GHISA (G20)	

KONTRACT 550-750-1250-1500



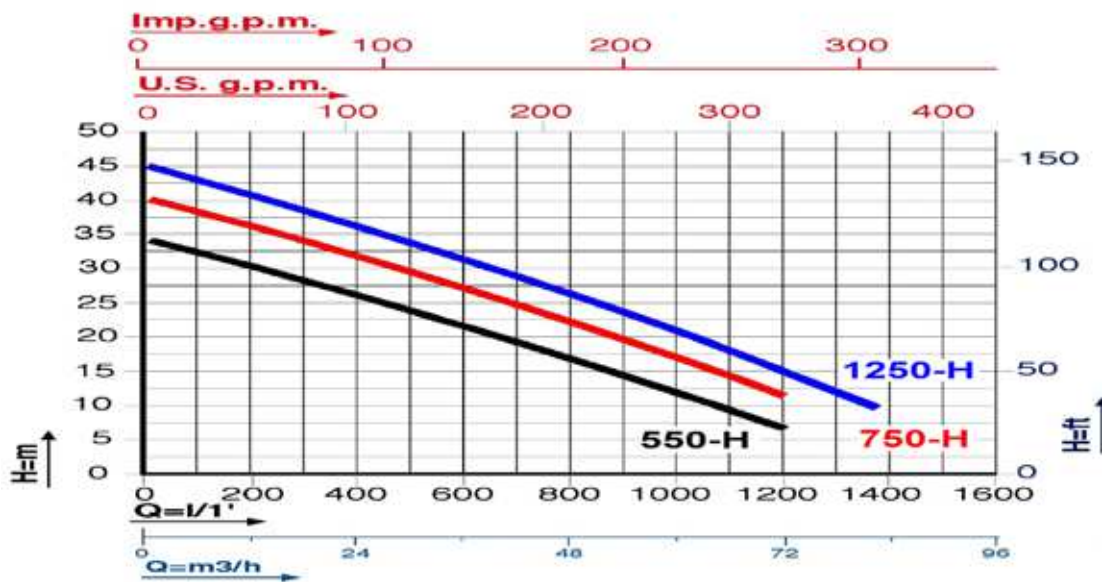
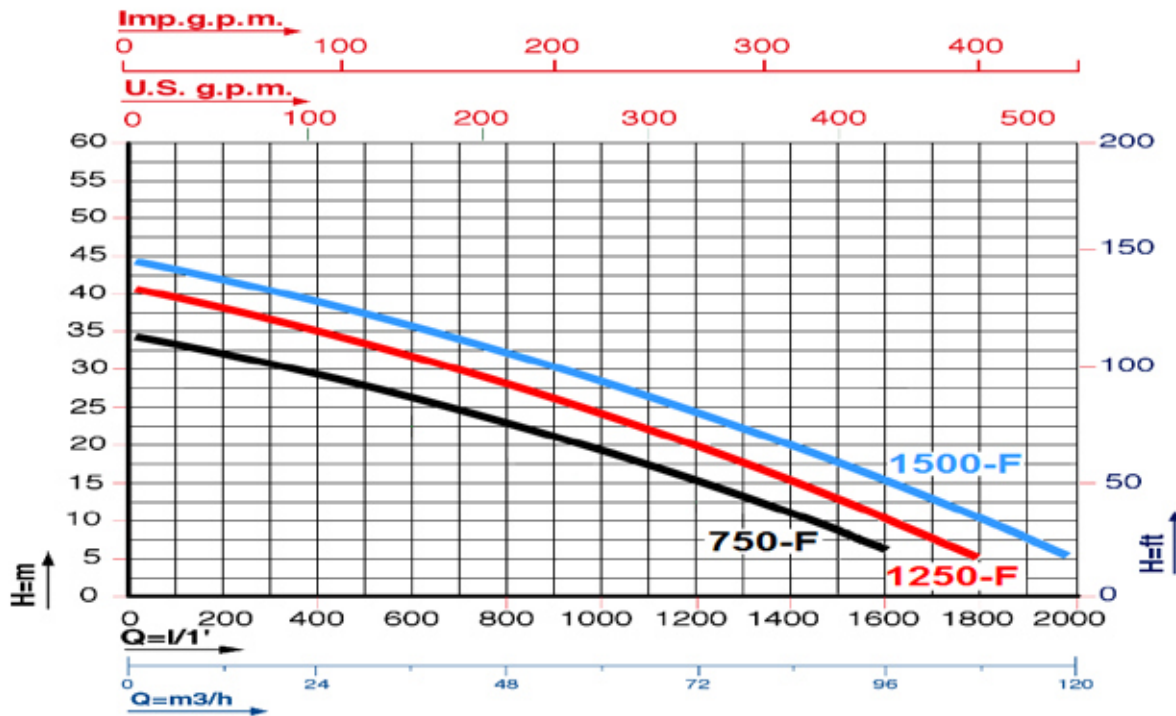

Caratteristiche di funzionamento a 2800 rpm 50Hz e 3450 rpm 60Hz - Performances at 2800 rpm 50 Hz and 3450 rpm 60 Hz Le prestazioni valgono per liquidi con densità $\rho = 1,0 \text{ kg/dm}^3$ ed una viscosità $\nu = 1 \text{ mm}^2/\text{s}$ /

MODELLO / MODEL	VOLTAGGIO VOLTAGE 50Hz	DATI ELETTRICI / ELECTRICAL DATA						DATI IDRAULICI / HYDRAULIC DATA												
		P1 max		P2 nom		I max	Condensatore- Capacitor		m ³ /h											
		kW	kW	HP	Ampere	μF	VC	0	3	12	21	30	42	54	72	84	96	108	120	
KONTRACT 550 H	3 x 380-400V	7,5	5,5	7,5	14,5	---	---	H (m)	0	50	200	350	500	700	900	1200	1400	1600	1800	2000
KONTRACT 750 H	3 x 380-400V	10,0	7,5	10	17,5	---	---		34	32,5	30	27	23	20	12,5	7,5	---	---	---	---
KONTRACT 750 F	3 x 380-400V	10,0	7,5	10	17,5	---	---		34	33,5	32,5	30	27,5	25	22,5	15	11,5	7	---	---
KONTRACT 1250 H	3 x 380-400V	13,0	12,5	16,5	23,0	---	---		45	44	41,5	37,5	33,5	28	23	15	10	---	---	---
KONTRACT 1250 F	3 x 380-400V	13,0	12,5	16,5	23,0	---	---		41	40	37,5	36	33,5	30	26	20	15	10	6	---
KONTRACT 1500 F	3 x 380-400V	18,0	15	20	30,0	---	---		45	44	42,5	40	37,5	33,5	28	24	20	15	10	5

PRELEVANZA TOTALE IN METRI COLONNA ACQUA
TOTAL PUMP HEAD AND WATER COLUMN HEIGHT IN m.

DIMENSIONI E PESI / SIZE AND WEIGHT DATA:

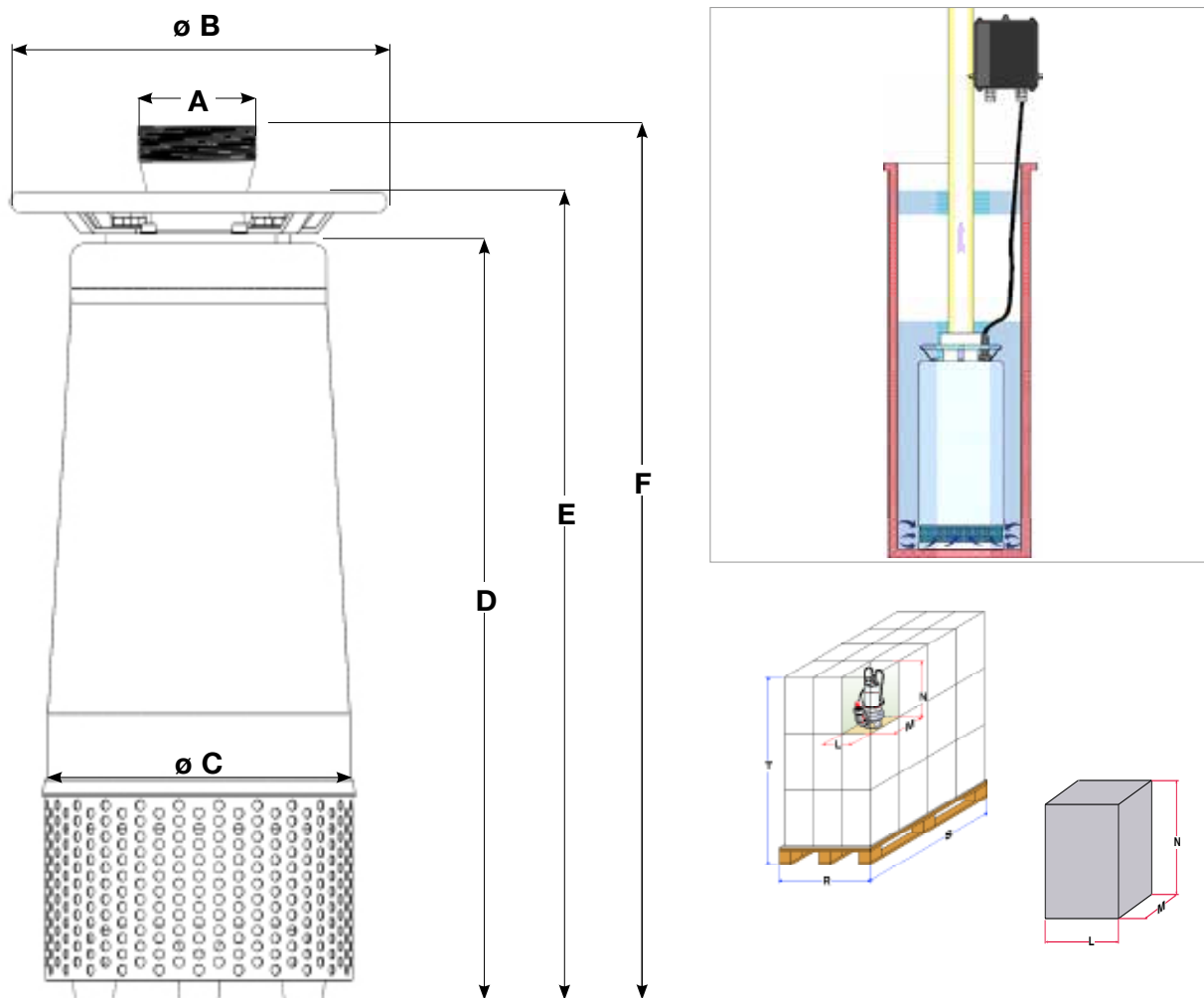

MODELLO / MODEL	DIMENSIONI POMPA in mm. / PUMP DIMENSIONS in mm.					
	A	B	C	D	E	F
KONTRACT 550 T H	4"*	360	300	725	770	840
KONTRACT 750 T H/F	4"*	360	300	725	770	840
KONTRACT 1250 T H/F	4"*	360	300	725	770	840
KONTRACT 1500 T F	4"*	360	300	725	770	840

MODELLO / MODEL	DIMENSIONI SCATOLA / PACKING DIMENSIONS			
	L mm.	M mm.	N mm.	Peso/weight
KONTRACT 550 T H	400	450	1000	90
KONTRACT 750 T H/F	400	450	1000	92
KONTRACT 1250 T H/F	400	450	1000	95,5
KONTRACT 1500 T F	400	450	1000	96

* OPTIONAL : 3" OR 6" ON REQUEST

SPRING



ELETTROPOMPE SOMMERGIBILI PER FONTANE E SVUOTAMENTO DI PISCINE SUBMERSIBLE ELECTRIC PUMPS FOR FOUNTAINS AND SWIMMING POOLS EMPTYING OPERATIONS

SERVIZIO CONTINUO ALTERNATO - ALTERNATED CONTINUE SERVICE

PREVALENZA : 8,0 mt. ÷ 16,5 mt.
PORTATA : 9,0 m³/h ÷ 24,0 m³/h
POTENZA NOMINALE : 0,25 kW (0,33HP) ÷ 1,1kW (1,5HP)

PUMP HEAD : 8,0 mt ÷ 16,5 mt
DELIVERY : 9,0 m³/h ÷ 24,0 m³/h
RATED HORSEPOWER : 0,25 kW (0,33HP) ÷ 1,1 kW (1,5HP)

APPLICAZIONI

- SVUOTAMENTO DI PISCINE.
- GIOCHI D'ACQUA.

APPLICATIONS

- SWIMMING POOLS EMPTYING OPERATIONS.
- WATER-PLAY.

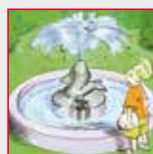

CARATTERISTICHE DI COSTRUZIONE:

- ELETTOPOMPA A DOPPIA CAMERA (MOTORE, TENUTA MECCANICA).
 - MOTORE A BAGNO D'OLIO (BIODEGRADABILE E DIELETTRICO) PER RAFFREDDAMENTO E LUBRIFICAZIONE CUSCINETTI.
 - ANELLO DI TENUTA LATO MOTORE.
 - TENUTA MECCANICA A BAGNO D'OLIO.
 - IMMERSIONE MASSIMA: mt. 5.
 - GRADO DI PROTEZIONE IP 68.
 - CLASSE DI ISOLAMENTO: F.
 - TEMPERATURA MAX. LIQUIDO POMPATO: 35°C.
 - VERSIONI: Monofase: 220-277V/50Hz e 220-277V/60 Hz con protettore termico incorporato e condensatore permanentemente inserito.
Trifase: 220-277V/50Hz o 380-480V/50Hz e 220-277V/60Hz o 380-480V/60Hz con protezione da sovraccarico a cura dell'utente.
 - POTENZA MOTORE:
Da 0,25 kW (0,33 Hp) a 0,45 kW (0,6Hp) solo versioni monofase.
Da 0,6 kW (0,8 Hp) a 1,1 kW (1,5Hp) versioni monofase e trifase.
 - VERSIONI MONOFASI AUTOMATICHE CON GALLEGGIANTE O MANUALI SENZA GALLEGGIANTE.
 - CAVO STANDARD:
Monofase: 10 metri H07RN-F per versione normale (aut.-man).
Trifase: 10 metri H07RN-F.
- SPECIALI VOLTAGGI E FREQUENZE A RICHIESTA.

DESIGN ENGINEERING:

- DOUBLE CHAMBER ELECTRIC PUMP (MOTOR, MECHANICAL SEAL).
 - OIL BATH MOTOR (BIODEGRADABLE AND DIELECTRIC) FOR COOLING AND BEARING LUBRICATION.
 - SEALING RING - ENGINE FACE.
 - OIL BATH MECHANICAL SEALS.
 - PERMISSIBLE DRAUGHT OF WATER: 5 m.
 - IP 68 PROTECTION CLASS.
 - CLASS "F" INSULATION.
 - MAX. PUMPED LIQUID TEMPERATURE: 35°C.
 - VERSIONS: Single Phase: 220-277V/50 Hz or 220-277V/60 Hz with built in thermal protection and permanent capacitor.
Three Phases : 220-277V/50 Hz or 380-480V/50Hz and 220-277V/60Hz or 380-480V/60Hz with overload protection care of the User.
 - MOTOR POWER:
From 0,25 kW (0,33 HP) to 0,45 kW (0,6 HP) only single phase versions.
From 0,6 kW (0,8 HP) to 1,1 kW (1,5HP) single phase and three phase versions.
 - AUTOMATIC SINGLE PHASE VERSIONS WITH FLOATER OR MANUAL SINGLE PHASE VERSIONS, WITHOUT FLOATER.
 - STANDARD CABLE FEATURES:
Single phase: 10 metres H07RN-F for the standard version (automatic-manual).
Three phases: 10 metres H07RN-F.
- CUSTOMISED VOLTAGE AND FREQUENCY RATING AVAILABLE ON DEMAND.

TABELLA MATERIALI / MATERIALS TABLE:

Pos.	Componente / Component		Materiale / Materials
A	Carcassa esterna / External housing		ACCIAIO INOX AISI 304 - DIN 1.4301 STAINLESS STEEL
B	Girante / Impeller	SPRING 80-100-150	TECNOPOLIMERO / TECNOPOLYMER
		SPRING 30-60	
C	Albero (lato pompa) / Shaft (pump side)		SPRING 30-60
			SPRING 80-100-150
D	Tenuta meccanica / Mechanical Seal	Lato motore / Motor face	SPRING 30-60
			SPRING 80-100-150
	Lato pompa / Pump face	SPRING 30-60	GRAFITE - CERAMICA / GRAPHITE - CERAMIC
		SPRING 80-100-150	GRAFITE-CARBURIO DI SILICIO / GRAPHITE - SILICON CARBIDE
E	Oring		NBR
G	Portamotore / Motor holder		ACCIAIO INOX AISI 304 - DIN 1.4301 STAINLESS STEEL
H	Carcassa motore / Motor housing		
I	Coperchio + maniglia / Cover + handle	SPRING 30-60	TECNOPOLIMERO / TECNOPOLYMER
		SPRING 80-100-150	
L	Diffusore / Diffuser		ACCIAIO INOX AISI 304 - DIN 1.4301 STAINLESS STEEL
Q	Filtro / Filter		

SPRING 30 - 60

SPRING 80 - 100 - 150

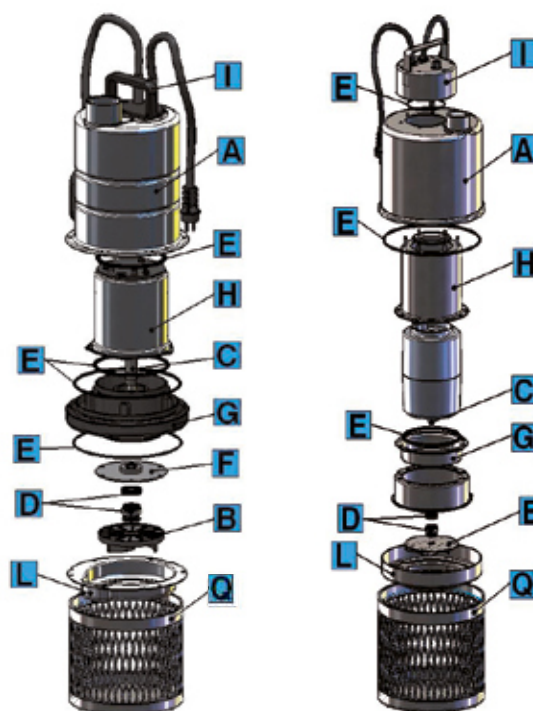

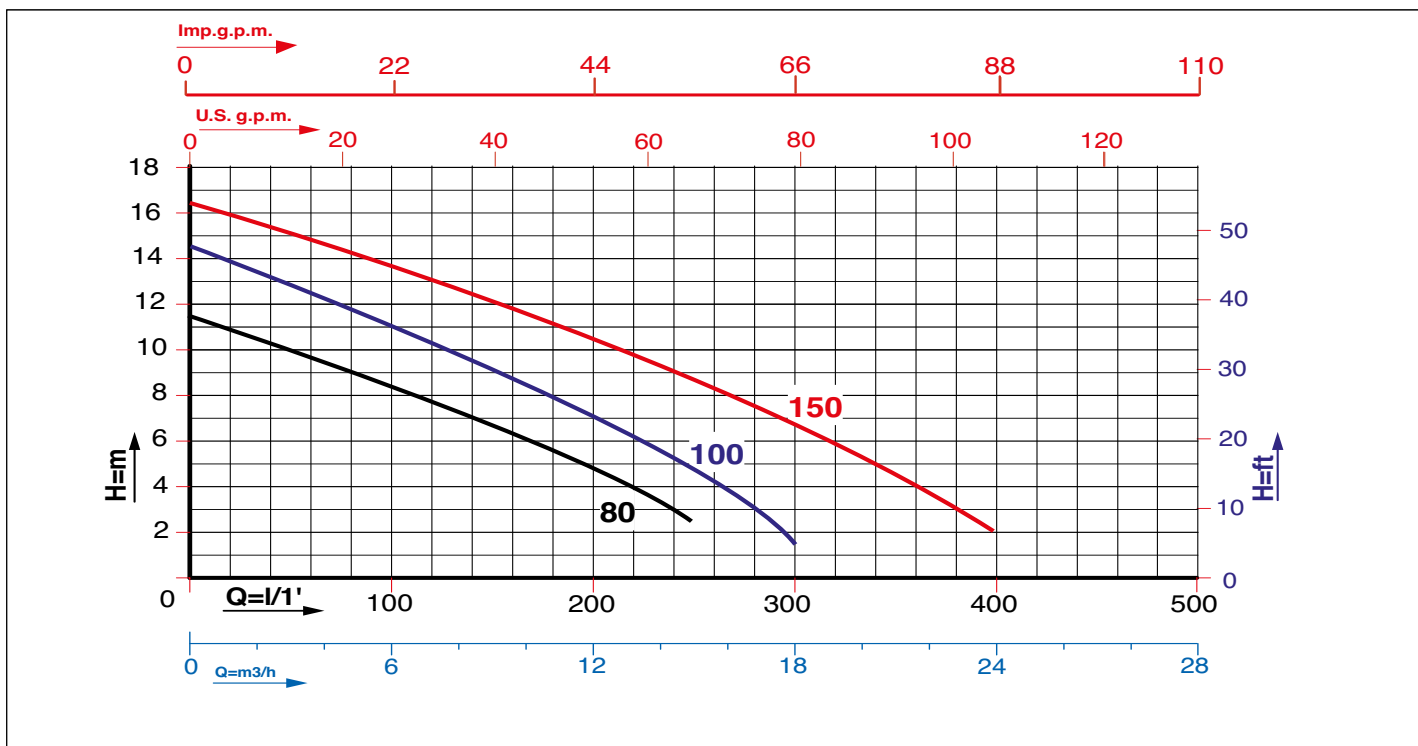
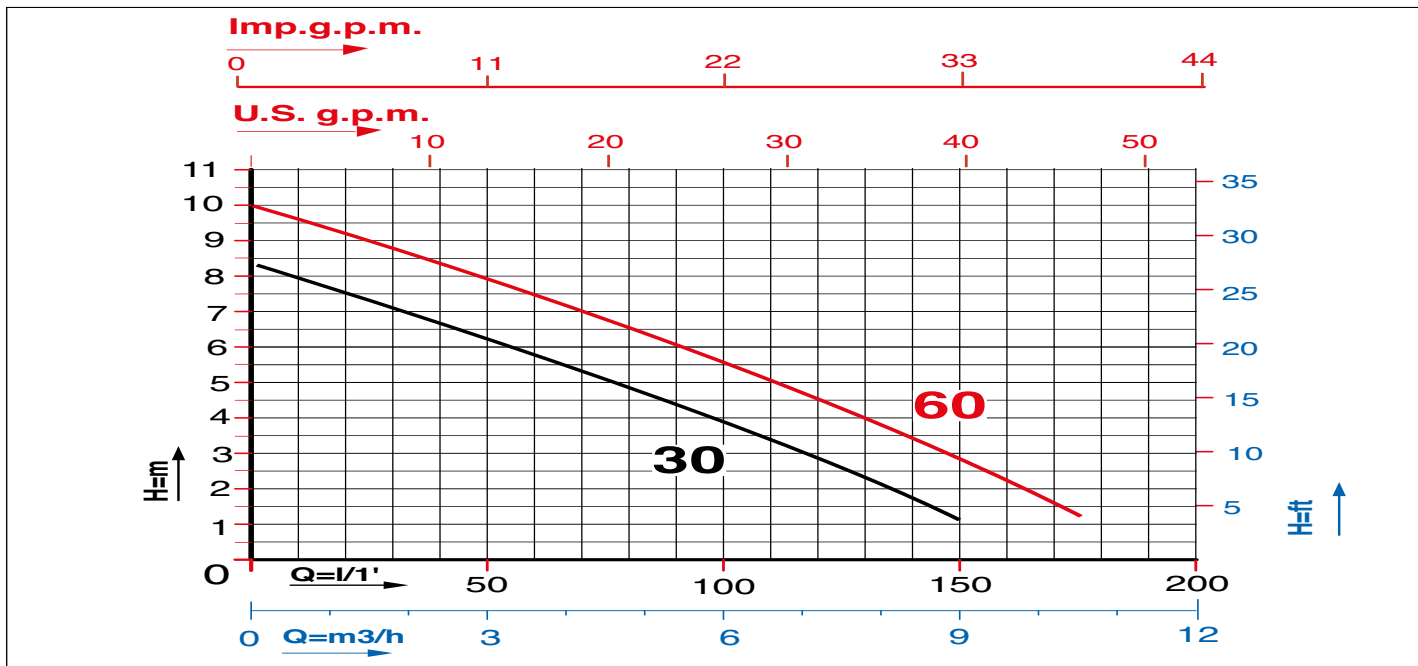

Caratteristiche di funzionamento a 2800 rpm 50Hz e 3450 rpm 60Hz - Performances at 2800 rpm 50 Hz and 3450 rpm 60 Hz

Le prestazioni valgono per liquidi con densità $\rho = 1,0 \text{ kg/dm}^3$ ed una viscosità $\nu = 1 \text{ mm}^2/\text{s}$ / The performance data holds true for liquids with a $\rho = 1,0 \text{ kg/dm}^3$ density and a $\nu = 1 \text{ mm}^2/\text{s}$ viscosity.

MODELLO MODEL	VOLTAGGIO VOLTAGE 50 Hz	DATI ELETTRICI / ELECTRICAL DATA						DATI IDRAULICI / HYDRAULIC DATA											
		P1 max kW	P2 nom. kW	HP	I max Ampere	Condensatore Capacitor μF VC		m ³ /h	0	2,4	4,5	7,2	9	10,5	15	18	24		
SPRING 30 M	1 x 220-230V	0,5	0,25	0,33	2,2	8,0	450	H (m) PREVALENZA TOTALE IN METRI COLONNA ACQUA / TOTAL PUMP HEAD AND WATER COLUMN HEIGHT IN ft.	l/min.	0	40	75	120	150	175	250	300	400	
SPRING 60 M	1 x 220-230V	0,7	0,45	0,6	3,0	10,0	450		8,0	6,6	5,2	7,4	1,0						
SPRING 60 T	3 x 380-400V	0,7	0,45	0,6	1,4	---	---		10,0	8,0	6,8	4,3	3,0	1,2					
SPRING 80 M	1 x 220-230V	1,1	0,6	0,8	4,5	16,0	450		11,5	10,5	9,5	7,5	6,2	5,0	2,0				
SPRING 80 T	3 x 380-400V	0,9	0,6	0,8	2,1	---	---		11,5	10,5	9,5	7,5	6,2	5,0	2,0				
SPRING 100 M	1 x 220-230V	1,5	0,75	1,0	6,5	20,0	450		14,5	13,5	12,0	10,5	9,5	8,0	4,0	1,5			
SPRING 100 T	3 x 380-400V	1,3	0,75	1,0	2,2	---	---		14,5	13,5	12,0	10,5	9,5	8,0	4,0	1,5			
SPRING 150 M	1 x 220-230V	2,0	1,1	1,5	10,6	30,0	450		16,5	15,5	14,5	13,0	12,1	11,2	9,0	7,0	2,0		
SPRING 150 T	3 x 380-400V	1,8	1,1	1,5	3,3	---	---		16,5	15,5	14,5	13,0	12,1	11,2	9,0	7,0	2,0		

DIMENSIONI E PESI / SIZE AND WEIGHT DATA:

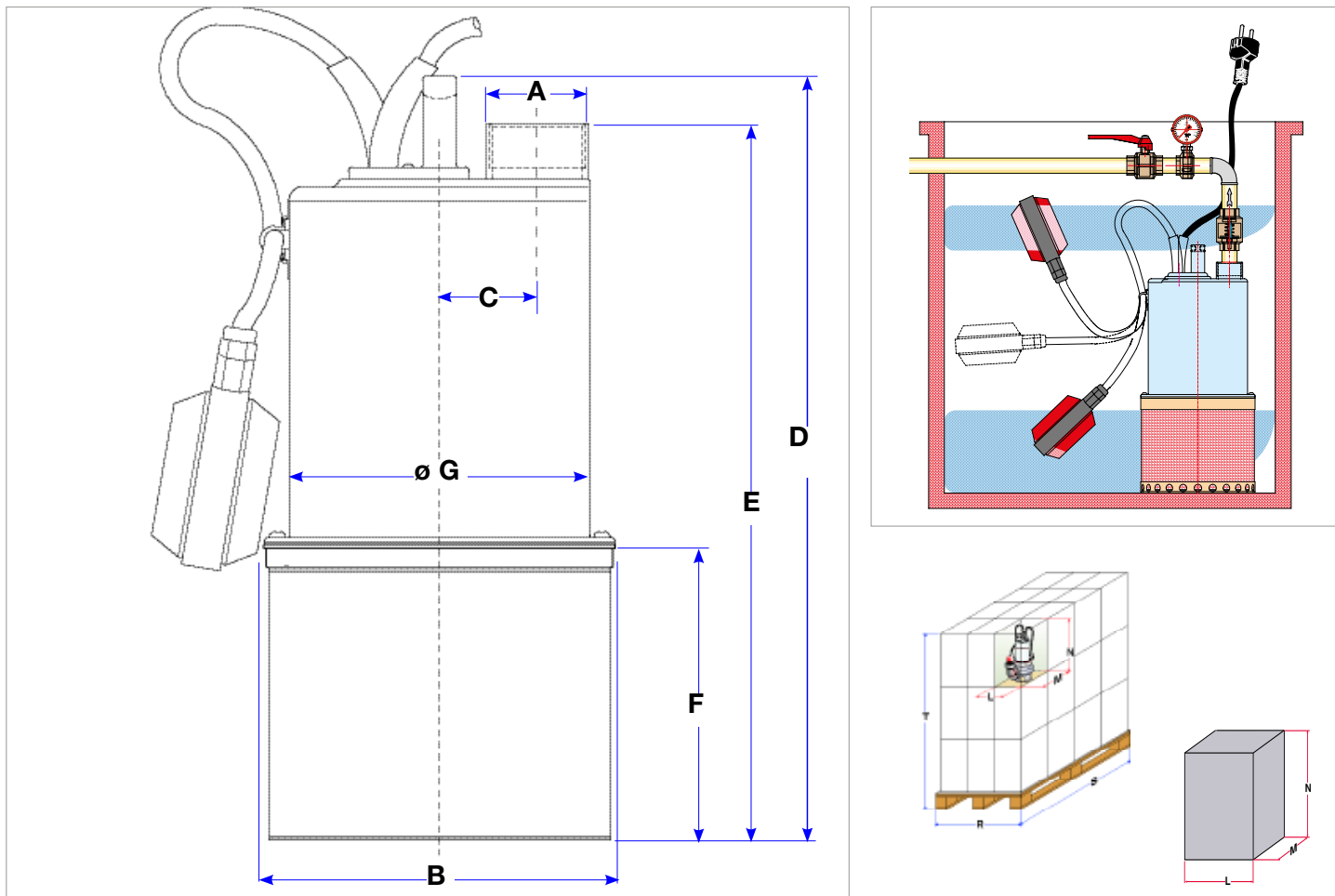

POMPE SOMMERGIBILI INOX
SUBMERSIBLE INOX PUMPS

MODELLO / MODEL	DIMENSIONI POMPA in mm. / PUMP DIMENSIONS in mm.						
	A	B	C	D	E	F	G
SPRING 30 M	1" 1/4	154	41	324	303	125	132
SPRING 60 M	1" 1/4	154	41	324	303	125	132
SPRING 60 T	1" 1/4	154	41	324	303	125	132
SPRING 80 M	1" 1/2	212,4	89,7	400	369	160	202,4
SPRING 80 T	1" 1/2	212,4	89,7	400	369	160	202,4
SPRING 100 M	1" 1/2	212,4	89,7	400	369	160	202,4
SPRING 100 T	1" 1/2	212,4	89,7	400	369	160	202,4
SPRING 150 M	2"	212,4	89,7	440,2	408,2	160	202,4
SPRING 150 T	2"	212,4	89,7	440,2	408,2	160	202,4

MODELLO / MODEL	DIMENSIONI SCATOLA / PACKING DIMENSIONS				DIMENSIONI PALLET / PALLET DIMENSIONS				
	L mm.	M mm.	N mm.	Peso / Weight Kg.	R mm.	S mm.	T mm.	nr. scatole/cartons	Peso / Weight Kg.
SPRING 30 M	190	230	410	5,5	800	1200	1790	80	450
SPRING 60 M	190	230	410	6,2	800	1200	1790	80	506
SPRING 60 T	190	230	410	6,5	800	1200	1790	80	530
SPRING 80 M	260	300	530	9	800	1200	1220	24	241
SPRING 80 T	260	300	530	9	800	1200	1220	24	241
SPRING 100 M	260	300	530	11	800	1200	1220	24	289
SPRING 100 T	260	300	530	11	800	1200	1220	24	289
SPRING 150 M	260	300	530	18	800	1200	1220	24	457
SPRING 150 T	260	300	530	18	800	1200	1220	24	457

DUMPER

70 - 80 - 100 - 140



ELETTROPOMPE SOMMERSIBILI DRENAGGIO PER ACQUE SPORCHE **SUBMERSIBLE ELECTRIC PUMPS FOR FOUL WASTEWATER DRAINAGE**

PREVALENZA : 10,5 mt. ÷ 19,5 mt.
PORTATA : 12,0 m³/h ÷ 24,0 m³/h
POTENZA NOMINALE : 0,5 kW (0,7HP) ÷ 1,1 kW (1,5HP)

PUMP HEAD : 10,5 mt ÷ 19,5 mt
DELIVERY : 12,0 m³/h ÷ 24,0 m³/h
RATED HORSEPOWER : 0,5 kW (0,7HP) ÷ 1,1 kW (1,5 HP)

APPLICAZIONI

- SVUOTAMENTO DI CANTINE, AUTORIMESSE, SCANTINATI.
- SVUOTAMENTO DI PISCINE VASCHE IN GENERE E SERBATOI.
- SVUOTAMENTO DA ACQUE PIOVANE, D'INFILTRAZIONE, DI SCARICO DI POZZETTI O VASCHE DI RACCOLTA.
- IRRIGAZIONE ORTI E GIARDINI.

APPLICATIONS

- CELLAR, GARAGE AND BASEMENT PUMP OUT.
- SWIMMING POOLS, ALL SORTS OF VATS, TANKS AND RESERVOIR PUMP OUT.
- RAIN, SEEPAGE, SUMP PIT AND CATCH TANK WATER PUMP OUT.
- GARDEN AND VEGETABLE-GARDEN IRRIGATION.



ARVEN[®]
WATER PUMPS

CARATTERISTICHE DI COSTRUZIONE:

- ELETTOPOMPA A DOPPIA CAMERA (MOTORE, TENUTA MECCANICA).
- MOTORE A BAGNO D'OLIO (BIODEGRADABILE E DIELETTRICO) PER RAFFREDDAMENTO E LUBRIFICAZIONE CUSCINETTI.
- ANELLO DI TENUTA LATO MOTORE.
- TENUTA MECCANICA A BAGNO D'OLIO.
- IMMERSIONE MASSIMA: mt. 5.
- GRADO DI PROTEZIONE IP 68.
- CLASSE DI ISOLAMENTO: F.
- TEMPERATURA MAX. LIQUIDO POMPATO:
25°C con pompa PARZIALMENTE immersa.
35°C con pompa TOTALMENTE immersa.
- PASSAGGIO LIBERO: 8 mm.
- VERSIONI: Monofase: 220-277V/50Hz o 220-277V/60Hz con protettore termico incorporato e condensatore permanentemente inserito.
Trifase: 220-277V/50Hz o 380-480V/50 Hz e 220-277V/60Hz o 380-480V/60Hz con protezione da sovraccarico a cura dell'utente.
- POTENZA MOTORE:
da 0,7 a 1,5 Hp versioni monofase e trifase.
- VERSIONI MONOFASI AUTOMATICHE SOLO FINO A 1,5HP
- CAVO STANDARD:
Monofase: 10 metri H07RN-F per versione normale (AUT.MAN.).
5 metri H07RN-F (solo DUMPER 70).
Trifase: 10 metri H07RN-F.

SPECIALI VOLTAGGI E FREQUENZE A RICHIESTA.

DESIGN ENGINEERING:

- DOUBLE CHAMBER ELECTRIC PUMP (MOTOR, MECHANICAL SEAL).
- OIL BATH MOTOR (BIODEGRADABLE AND DIELECTRIC) FOR COOLING AND BEARING LUBRICATION.
- SEALING RING - ENGINE FACE.
- Oil bath MECHANICAL SEALS.
- PERMISSIBLE DRAUGHT OF WATER: 5 m.
- IP 68 PROTECTION CLASS.
- CLASS "F" INSULATION.
- MAX. PUMPED LIQUID TEMPERATURE:
25°C with PARTIALLY submerged pump.
35°C with TOTALLY submerged pump.
- BY PASS SECTION: 8 mm.
- VERSIONS: Single Phase: 220-277V/50 Hz or 220-277V/60Hz with built in thermal protection and permanent capacitor.
Three Phases: 220-277V/50Hz or 380-480V/50Hz and 220-277V/60Hz or 380-480V/60 Hz with overload protection care of the User.
- MOTOR POWER:
From 0,7 to 1,5HP single phase and three phase versions.
- AUTOMATIC SINGLE PHASE VERSIONS up to only 1,5HP.
- STANDARD CABLE FEATURES:
Single phase: 10 metres H07RN-F for the standard version (automatic-manual).
5 metres H07RN-F (only DUMPER 70).
Three phases: 10 metres H07RN-F.

CUSTOMISED VOLTAGE AND FREQUENCY RATING AVAILABLE ON DEMAND.

TABELLA MATERIALI / MATERIALS TABLE:

Pos.	Componente / Component	Materiale / Materials	
A	Carcassa esterna / External housing	ACCIAIO INOX AISI 304 - DIN 1.4301 STAINLESS STEEL	
B	Girante / Impeller		DUMPER 70-80-100
		DUMPER 140	GHISA (G20) / CAST IRON
C	Albero (lato pompa) / Shaft (pump side)	ACCIAIO INOX AISI 316 DIN 1.4401 STAINLESS STEEL	
D	Tenuta meccanica / Mechanical Seal	Lato motore / Motor face	ANELLO DI TENUTA NBR / NBR SEAL RING
		Lato pompa / Pump face	CARBURO DI SILICIO - CERAMICA SILICON CARBIDE - CERAMIC
E	Oring	NBR	
I	Coperchio / Cover	ACCIAIO INOX AISI 304 - DIN 1.4301 STAINLESS STEEL	
N	Base d'aspirazione / Suction base		
L	Diffusore / Diffuser	GHISA (G.20) CAST IRON	
P	Corpo pompa / Pump body		

DUMPER 70 - 80 - 100

DUMPER 140

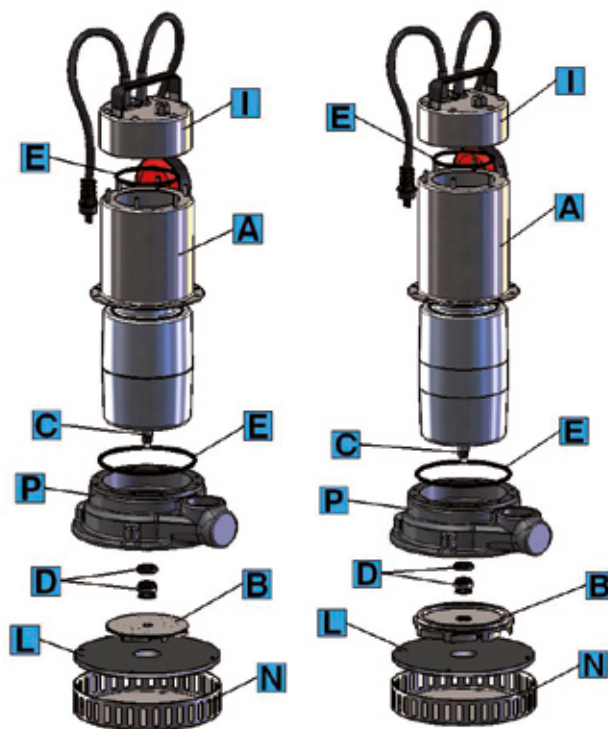

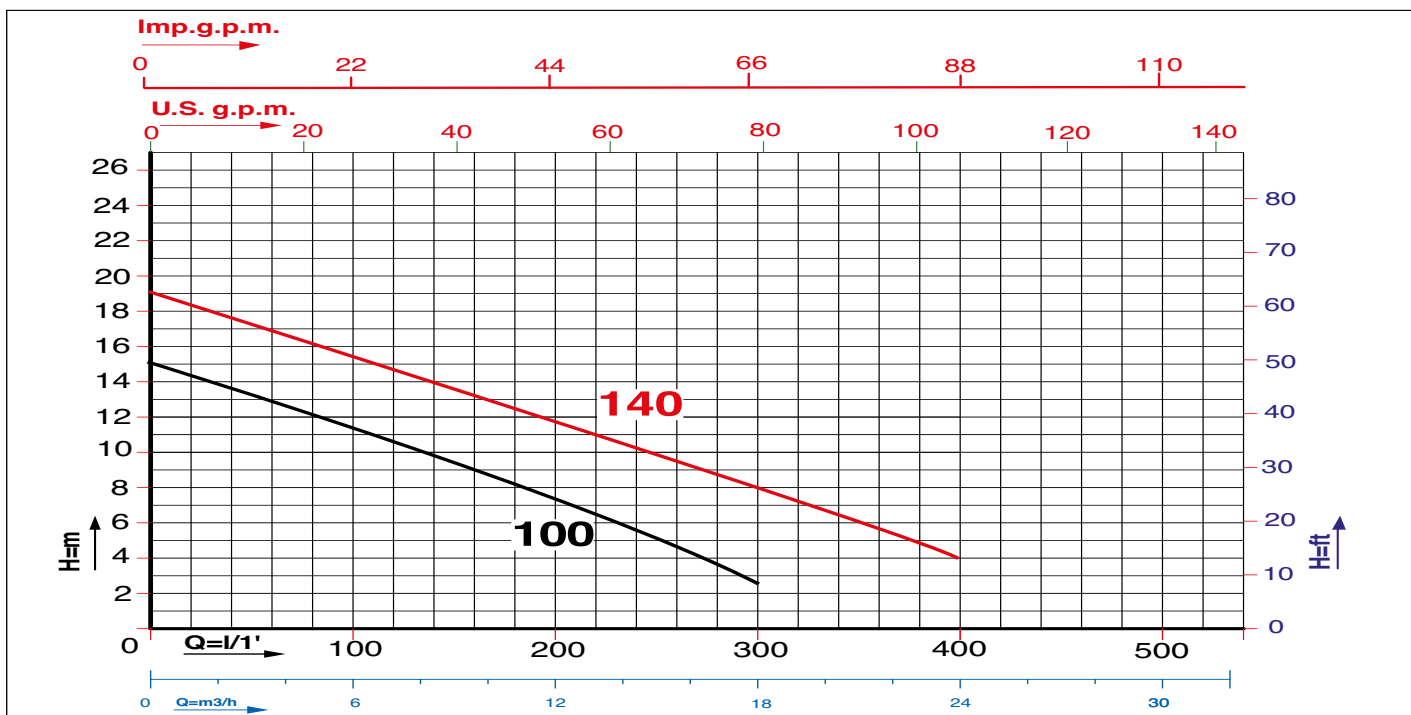
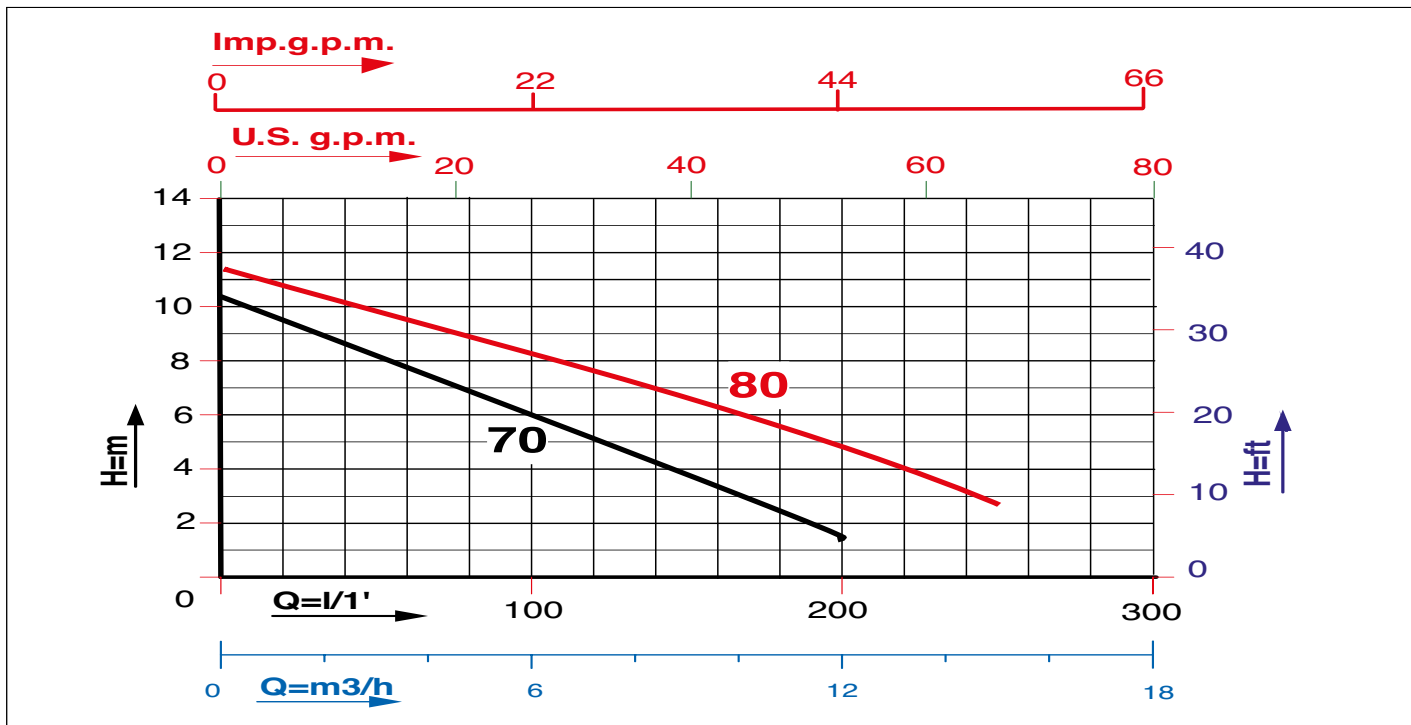

Caratteristiche di funzionamento a 2800 rpm 50Hz e 3450 rpm 60Hz - Performances at 2800 rpm 50 Hz and 3450 rpm 60 Hz
 Le prestazioni valgono per liquidi con densità $\rho = 1,0 \text{ kg/dm}^3$ ed una viscosità $\nu = 1 \text{ mm}^2/\text{s}$ / The performance data holds true for liquids with a $\rho = 1,0 \text{ kg/dm}^3$ density and a $\nu = 1 \text{ mm}^2/\text{s}$ viscosity.

MODELLO MODEL	VOLTAGGIO VOLTAGE 50 Hz	DATI ELETTRICI / ELECTRICAL DATA				DATI IDRAULICI / HYDRAULIC DATA										
		P1 max kW	P2 nom. kW	I max HP	Condensatore Capacitor μF	VC	H (m)									
							m³/h	0	1,5	3	6	9	12	15	18	24
DUMPER 70 M	1 x 220-230V	0,9	0,5	0,7	4,5	14,5	450	10,5	9,0	7,8	6,0	3,4	1,6	---	---	---
DUMPER 80 M	1 x 220-230V	1,1	0,6	0,8	4,5	16,0	450	11,5	10,3	9,5	8,2	6,9	5,2	2,6	---	---
DUMPER 80 T	3 x 380-400V	1,0	0,6	0,8	2,1	---	---	11,5	10,3	9,5	8,2	6,9	5,2	2,6	---	---
DUMPER 100 M	1 x 220-230V	1,3	0,75	1,0	6,5	20,0	450	15,0	14,0	12,8	11,2	9,2	7,4	5,2	2,6	---
DUMPER 100 T	3 x 380-400V	1,1	0,75	1,0	2,6	---	---	15,0	14,0	12,8	11,2	9,2	7,4	5,2	2,6	---
DUMPER 140 M	1 x 220-230V	2,0	1,1	1,5	9,0	30,0	450	19,5	19,0	18,5	17,5	16,0	14,0	11,8	9,2	4,0
DUMPER 140 T	3 x 380-400V	1,7	1,1	1,5	3,0	---	---	19,5	19,0	18,5	17,5	16,0	14,0	11,8	9,2	4,0

PREVALENZA TOTALE IN METRI COLONNA ACQUA / TOTAL PUMP HEAD AND WATER COLUMN HEIGHT IN m.

DIMENSIONI E PESI / SIZE AND WEIGHT DATA:

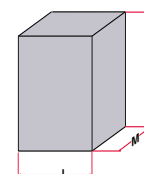
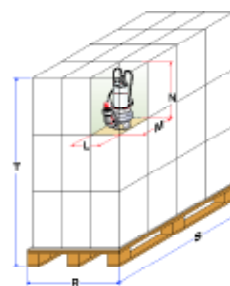
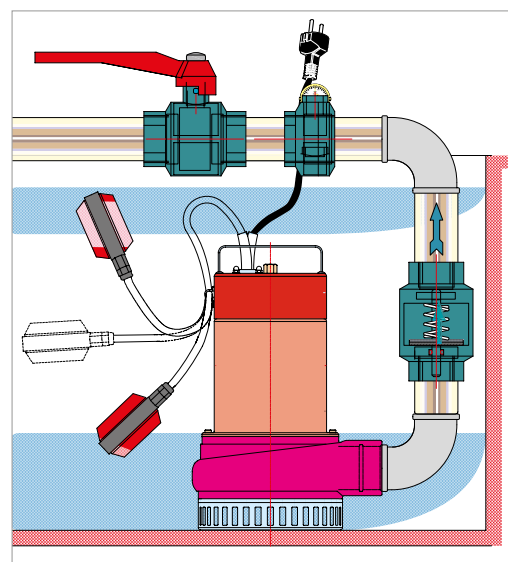
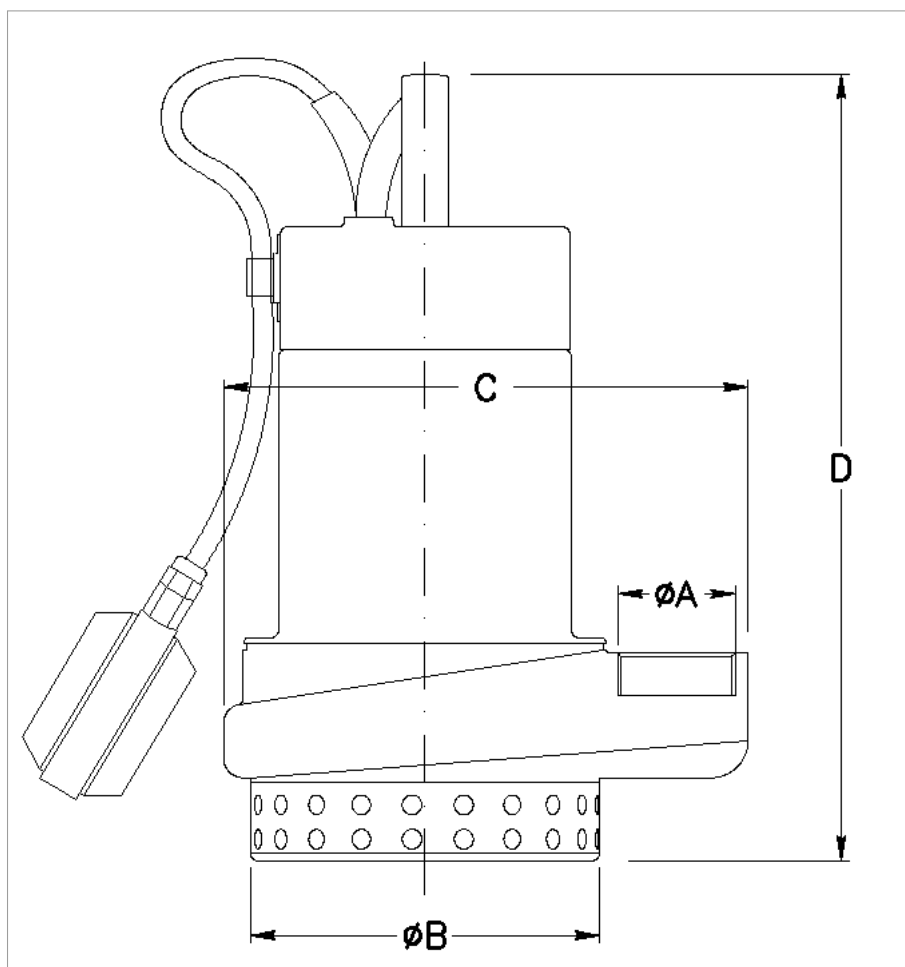

MODELLO / MODEL	DIMENSIONI POMPA in mm / PUMP DIMENSIONS in mm.			
	A	B	C	D
DUMPER 70 M	1" 1/2	190	213,5	300
DUMPER 80 M	1" 1/2	190	213,5	300
DUMPER 80 T	1" 1/2	190	213,5	300
DUMPER 100 M	1" 1/2	190	213,5	300
DUMPER 100 T	1" 1/2	190	213,5	300
DUMPER 140 M	1" 1/2	190	213,5	344
DUMPER 140 T	1" 1/2	190	213,5	344

MODELLO / MODEL	DIMENSIONI SCATOLA / PACKING DIMENSIONS				DIMENSIONI PALLET / PALLET DIMENSIONS				
	L mm.	M mm.	N mm.	Peso / Weight Kg.	R mm.	S mm.	T mm.	nr. scatole/cartons	Peso / Weight Kg.
DUMPER 70 M	190	220	320	13,0	800	1200	1130	60	745
DUMPER 80 M	190	220	320	13,0	800	1200	1130	60	805
DUMPER 80 T	190	220	320	13,0	800	1200	1130	60	805
DUMPER 100 M	190	220	320	13,5	800	1200	1130	60	835
DUMPER 100 T	190	220	320	13,5	800	1200	1130	60	835
DUMPER 140 M	260	320	340	18,2	800	1200	1400	36	670
DUMPER 140 T	260	320	340	18,2	800	1200	1400	36	670

DUMPER

150 - 200 - 300



ELETTROPOMPE SOMMERSIBILI DRENAGGIO PER ACQUE SPORCHE **SUBMERSIBLE ELECTRIC PUMPS FOR FOUL WASTEWATER DRAINAGE**

PREVALENZA : 21,0 mt. ÷ 26,5 mt.
PORTATA : 21,0 m³/h ÷ 30,0 m³/h
POTENZA NOMINALE : 1,5 kW (2HP) ÷ 2,25 kW (3HP)

PUMP HEAD : 21,0 mt. ÷ 26,5 mt
DELIVERY : 21,0 m³/h ÷ 30,0 m³/h
RATED HORSEPOWER : 1,5 kW (2,0HP) ÷ 2,25 kW (3,0HP)

APPLICAZIONI

- SVUOTAMENTO DI CANTINE, AUTORIMESSE, SCANTINATI.
- SVUOTAMENTO DI PISCINE VASCHE IN GENERE E SERBATOI.
- SVUOTAMENTO DA ACQUE PIOVANE, D'INFILTRAZIONE, DI SCARICO DI POZZETTI O VASCHE DI RACCOLTA.
- IRRIGAZIONE ORTI E GIARDINI.

APPLICATIONS

- CELLAR, GARAGE AND BASEMENT PUMP OUT.
- SWIMMING POOLS, ALL SORTS OF VATS, TANKS AND RESERVOIR PUMP OUT.
- RAIN, SEEPAGE, SUMP PIT AND CATCH TANK WATER PUMP OUT.
- GARDEN AND VEGETABLE-GARDEN IRRIGATION.



ARVEN[®]
WATER PUMPS

CARATTERISTICHE DI COSTRUZIONE:

- ELETTOPOMPA A DOPPIA CAMERA (MOTORE, TENUTA MECCANICA).
 - MOTORE A BAGNO D'OLIO (BIODEGRADABILE E DIELETTRICO) PER RAFFREDDAMENTO E LUBRIFICAZIONE CUSCINETTI.
 - ANELLO DI TENUTA LATO MOTORE.
 - TENUTA MECCANICA A BAGNO D'OLIO.
 - DOPPIA TENUTA MECCANICA: LATO MOTORE A BAGNO D'OLIO LATO POMPA BAGNO D'ACQUA
 - IMMERSIONE MASSIMA: mt. 5.
 - GRADO DI PROTEZIONE IP 68.
 - CLASSE DI ISOLAMENTO: F.
 - TEMPERATURA MAX. LIQUIDO POMPATO:
25°C con pompa PARZIALMENTE immersa.
35°C con pompa TOTALMENTE immersa.
 - PASSAGGIO LIBERO: 8 mm.
 - VERSIONI: Monofase: 220-277V/50Hz o 220-277V/60 Hz con protettore termico incorporato e condensatore permanentemente inserito.
Trifase: 220-277V/50 Hz o 380-480V/50Hz e 220-277V/60Hz o 380-480V/60Hz con protezione da sovraccarico a cura dell'utente.
 - POTENZA MOTORE:
DA 2 a 2,5 Hp versioni monofase e trifase.
DA 3 Hp SOLO VERSIONE TRIFASE.
 - VERSIONI MONOFASI AUTOMATICHE SOLO FINO A 2,5HP.
 - CAVO STANDARD:
Monofase: 10 metri H07RN-F per versione normale (AUT.MAN.).
Trifase: 10 metri H07RN-F.
- SPECIALI VOLTAGGI E FREQUENZE A RICHIESTA.

OPTIONAL:

- SISTEMI DI DISCESA DN50 PER IMPIANTI FISSI (VEDERE PAGINA 108).

DESIGN ENGINEERING:

- DOUBLE CHAMBER ELECTRIC PUMP (MOTOR, MECHANICAL SEAL).
 - OIL BATH MOTOR (BIODEGRADABLE AND DIELECTRIC) FOR COOLING AND BEARING LUBRICATION.
 - SEALING RING - ENGINE FACE.
 - OIL BATH MECHANICAL SEALS.
 - DOUBLE MECHANICAL SEALS: ENGINE FACE: OIL BATH. PUMP FACE: WATER BATH.
 - PERMISSIBLE DRAUGHT OF WATER: 5 m.
 - IP 68 PROTECTION CLASS.
 - CLASS "F" INSULATION.
 - MAX. PUMPED LIQUID TEMPERATURE:
25°C with PARTIALLY submerged pump.
35°C with tTOTALLY submerged pump.
 - BY PASS SECTION: 8 mm
 - VERSIONS: Single Phase: 220-277V/50Hz or 220-277V/60Hz with built in thermal protection and permanent capacitor.
Three Phases : 220- 277V/50 Hz or 380-480 V/50Hz and 220 -277V/60Hz or 380-480V/60 Hz with overload protection care of the User.
 - MOTOR POWER:
From 2,0 to 2,5 HP single phase and three phases versions.
From 3,0 HP ONLY THREE PHASES VERSIONS.
 - AUTOMATIC SINGLE PHASE VERSIONS up to only 2,5HP
 - STANDARD CABLE FEATURES:
Single phase: 10 metres H07RN-F for the standard version (automatic-manual)
Three phases: 10 metres H07RN-F.
- CUSTOMISED VOLTAGE AND FREQUENCY RATING AVAILABLE ON DEMAND.

OPTIONAL:

- DOWN STROKE GUIDE RAIL SYSTEMS DN50 (SEE PAGE 108).

TABELLA MATERIALI / MATERIALS TABLE:

Pos.	Componente / Component	Materiale / Materials
A	Carcassa esterna / External motor housing	ACCIAIO INOX AISI 304 - DIN 1.4301 STAINLESS STEEL
B	Girante / Impeller	GHISA G20 / CAST IRON
C	Albero (lato pompa) / Shaft (pump side)	ACCIAIO INOX AISI 316 - DIN 1.4401 STAINLESS STEEL
D	Tenuta meccanica Mechanical seal	Lato pompa / Pump face CARBURIO DI SILICIO-CERAMICA SILICON CARBIDE-CERAMIC
		Lato motore / Engine face GRAFITE-CERAMICA GRAPHITE-CERAMIC
E	O-ring	NBR
I	Coperchio / Cover	ACCIAIO INOX AISI 304 - DIN 1.4301 STAINLESS STEEL
L	Diffusore / Diffuser	
N	Base d'aspirazione / Suction base	
P	Corpo pompa / Pump body	GHISA G20 / CAST IRON

DUMPER 150 - 200 - 300

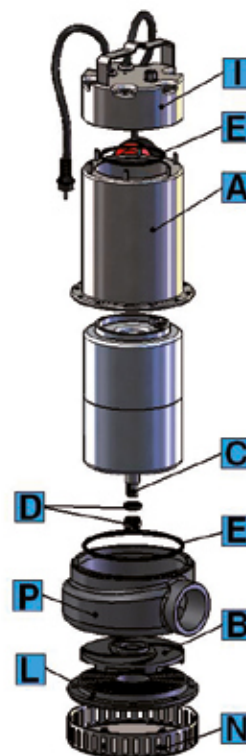

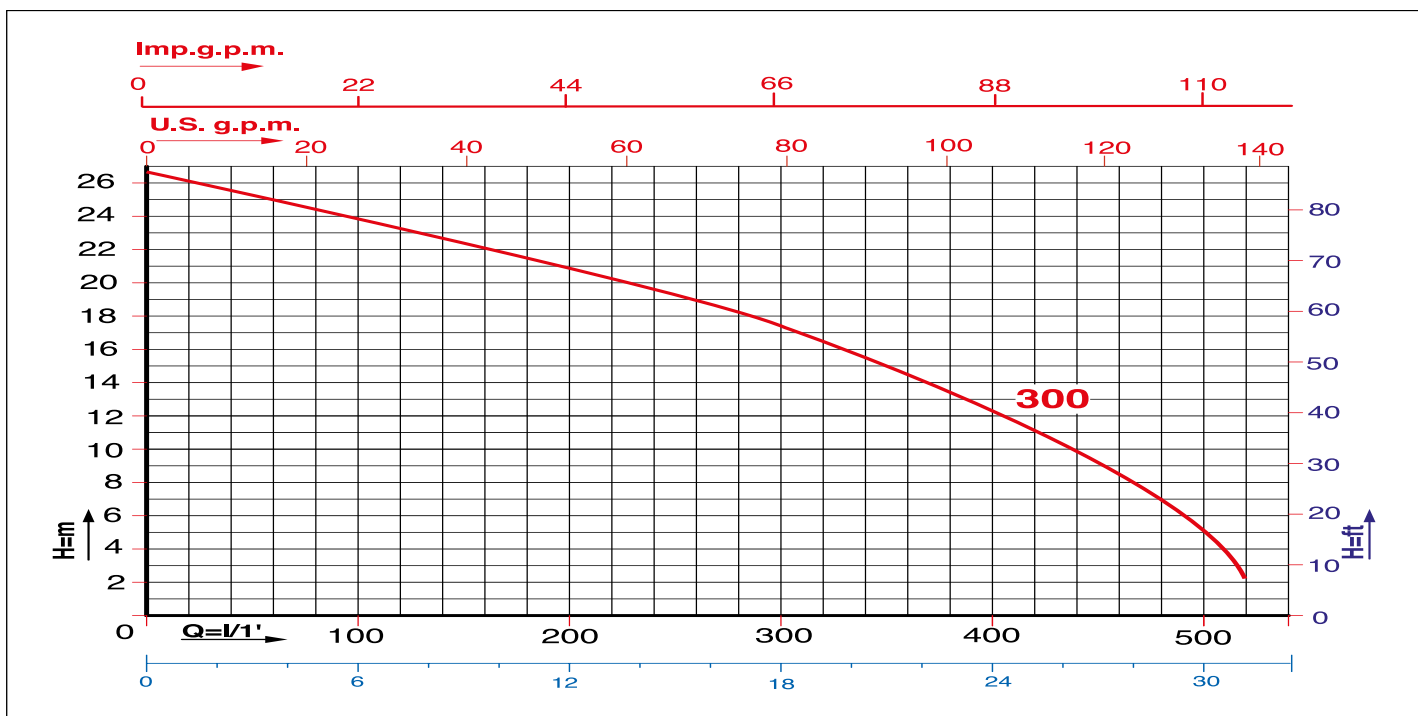
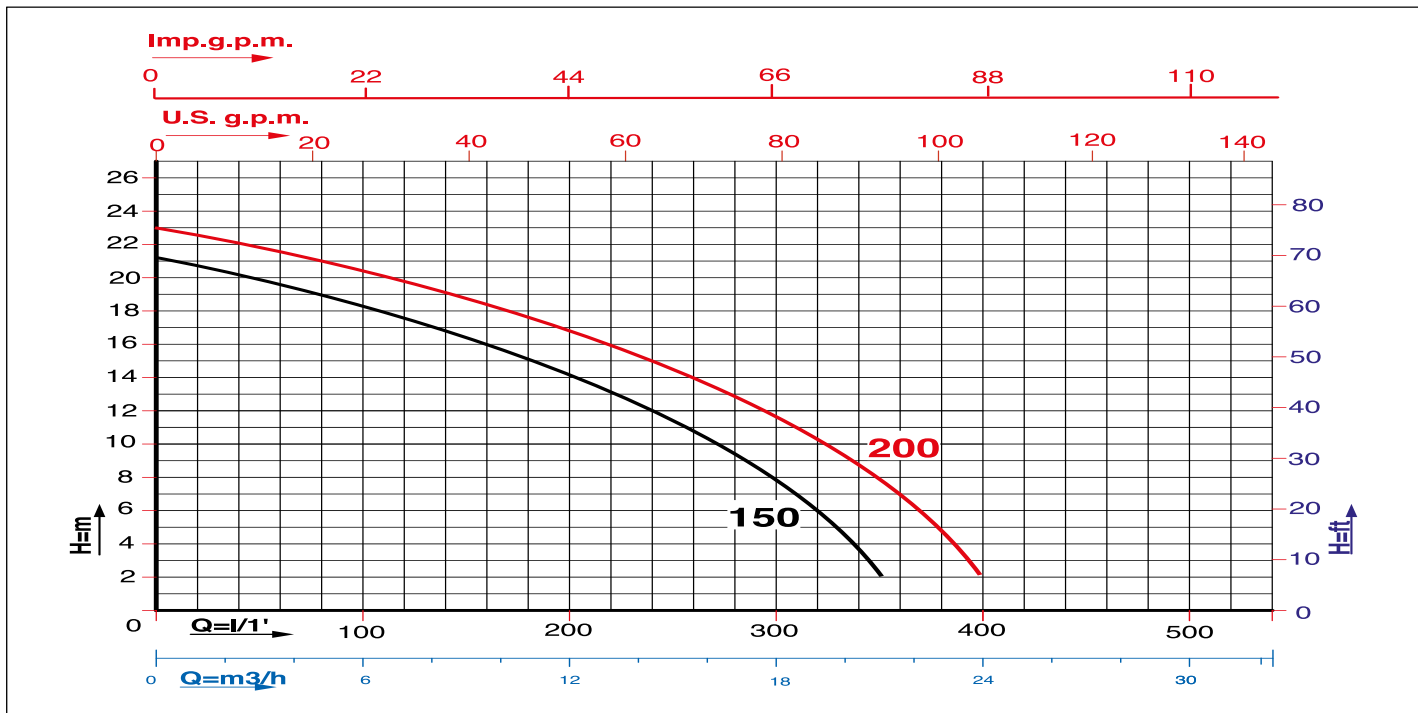

Caratteristiche di funzionamento a 2800 rpm 50Hz e 3450 rpm 60Hz - Performances at 2800 rpm 50 Hz and 3450 rpm 60 Hz
 Le prestazioni valgono per liquidi con densità $\rho = 1,0 \text{ kg/dm}^3$ ed una viscosità $\nu = 1 \text{ mm}^2/\text{s}$ / The performance data holds true for liquids with a $\rho = 1,0 \text{ kg/dm}^3$ density and a $\nu = 1 \text{ mm}^2/\text{s}$ viscosity.

MODELLO MODEL	VOLTAGGIO VOLTAGE 50 Hz	DATI ELETTRICI / ELECTRICAL DATA				DATI IDRAULICI / HYDRAULIC DATA											
		P1 max kW	P2 nom. kW	I max HP	Condensatore Capacitor µF	VC	m³/h	0	4,5	9	12	15	18	21	24	30	
DUMPER 150 M	1 x 220-230V	2,7	1,5	2	11,0	40,0	450	H (m)	0	75	150	200	250	300	350	400	500
DUMPER 150 T	3 x 380-400V	2,5	1,5	2	4,5	---	---		21,0	19,5	16,5	14,0	11,0	7,5	2,0		
DUMPER 200 M	1 x 220-230V	2,9	1,9	2,5	12,5	50,0	450		23,0	21,0	18,5	17,0	15,0	11,5	9,0	2,0	
DUMPER 200 T	3 x 380-400V	2,7	1,9	2,5	5,0	---	---		23,0	21,0	18,5	17,0	15,0	11,5	9,0	2,0	
DUMPER 300 T	3 x 380-400V	3,4	2,25	3	6	---	---		26,5	24,5	22,5	20,5	19,0	17,5	15,0	11,0	2,0

PREVALENZA TOTALE IN METRI COLONNA ACQUA / TOTAL PUMP HEAD AND WATER COLUMN HEIGHT IN M.

DIMENSIONI E PESI / SIZE AND WEIGHT DATA:

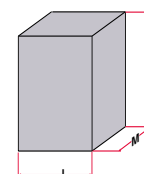
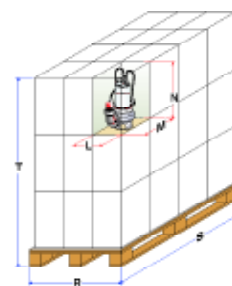
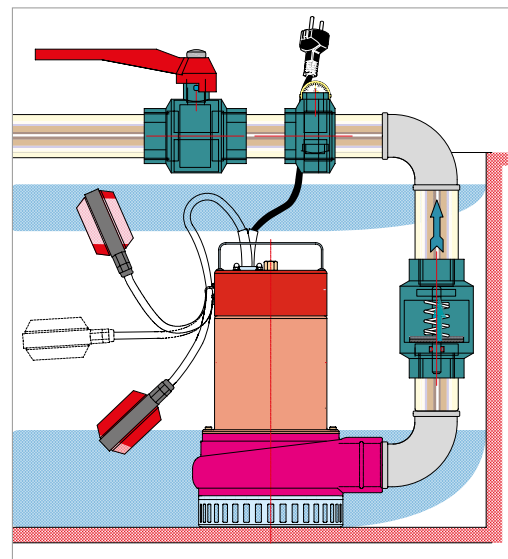
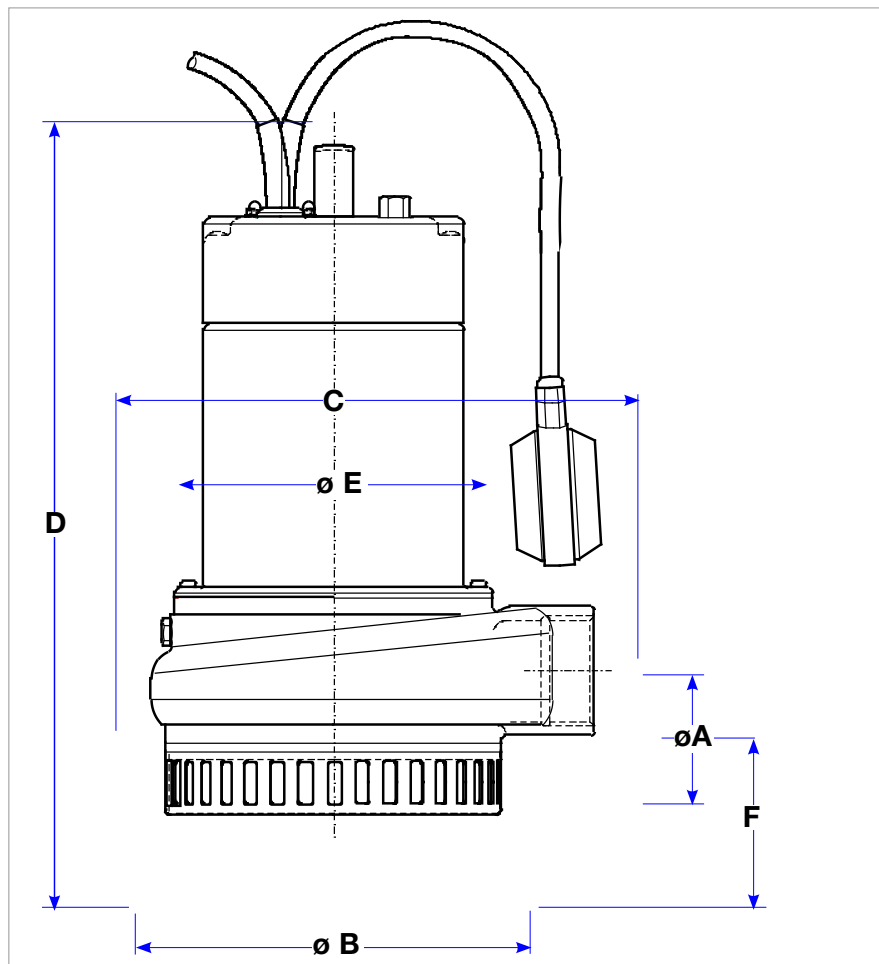

MODELLO / MODEL	DIMENSIONI POMPA in mm. / PUMP DIMENSIONS in mm.					
	A	B	C	D	E	F
DUMPER 150 M	2"	190	250	378	148	81,5
DUMPER 150 T	2"	190	250	378	148	81,5
DUMPER 200 M	2"	190	250	378	148	81,5
DUMPER 200 T	2"	190	250	378	148	81,5
DUMPER 300 T	2"	190	250	378	148	81,5

MODELLO / MODEL	DIMENSIONI SCATOLA / PACKING DIMENSIONS				DIMENSIONI PALLET / PALLET DIMENSIONS				
	L mm.	M mm.	N mm.	Peso / Weight Kg.	R mm.	S mm.	T mm.	nr. scatole/cartons	Peso / Weight Kg.
DUMPER 150 M	260	300	530	25,5	800	1200	1750	36	938
DUMPER 150 T	260	300	530	25,5	800	1200	1750	36	938
DUMPER 200 M	260	300	530	28,5	800	1200	1750	36	1046
DUMPER 200 T	260	300	530	28,5	800	1200	1750	36	1046
DUMPER 300 T	260	300	530	29,5	800	1200	1750	36	938

TIGER



ELETTROPOMPE SOMMERGIBILI VORTEX E BICANALI PER ACQUE CARICHE SUBMERSIBLE VORTEX AND BICANAL ELECTRIC PUMPS FOR WASTEWATER

PREVALENZA : 6,5 mt. ÷ 16,0 mt.
PORTATA : 12,0 m³/h ÷ 42,0 m³/h
POTENZA NOMINALE : 0,5 kW (0,7HP) ÷ 1,5 kW (2,0HP)
PASSAGGIO SOLIDI FINO A 50 mm.

APPLICAZIONI

- SVUOTAMENTO DI FOSSE DI DECANTAZIONE, POZZI NERI, POZZI DI RACCOLTA LIQUAMI.
- POMPAGGIO DI ACQUE LURIDE ANCHE CON CORPI SOLIDI IN SOSPENSIONE.
- MOVIMENTAZIONE DI ACQUE LURIDE AD USO DOMESTICO ED INDUSTRIALE.

PUMP HEAD : 6,5 mt ÷ 16,0 mt
DELIVERY : 12,0 m³/h ÷ 42,0 m³/h
RATED HORSEPOWER : 0,5 kW (0,7HP) ÷ 1,5 kW (2,0HP)
SOLID MATTER BYPASS up to 50 mm.

APPLICATIONS

- DECANTATION PIT, SEWAGE PIT AND SLURRY COLLECTION PIT PUMP OUT.
- PUMP OUT OF LAVATORY/FOUL WATER WITH POSSIBLE FLOATING SOLIDS CONTENTS.
- DOMESTIC AND INDUSTRIAL LAVATORY/BLACK WATER HANDLING SYSTEMS.



CARATTERISTICHE DI COSTRUZIONE:

- ELETTOPOMPA A DOPPIA CAMERA (MOTORE, TENUTA MECCANICA).
 - MOTORE A BAGNO D'OLIO (BIODEGRADABILE E DIELETTRICO) PER RAFFREDDAMENTO E LUBRIFICAZIONE CUSCINETTI.
 - ANELLO DI TENUTA LATO MOTORE.
 - TENUTA MECCANICA A BAGNO D'OLIO.
 - IMMERSIONE MASSIMA: mt. 5 .
 - GRADO DI PROTEZIONE IP 68 .
 - CLASSE DI ISOLAMENTO: F
 - TEMPERATURA MAX. LIQUIDO POMPATO:
25°C con pompa PARZIALMENTE immersa.
35°C con pompa TOTALMENTE immersa
 - PASSAGGIO LIBERO: 30 mm - TIGER 70.
35 mm - TIGER 80.
50 mm - TIGER 100 - 150 - 200.
 - VERSIONI: Monofase: 220-277V/50Hz e 220-277V/60Hz con protettore termico incorporato e condensatore permanentemente inserito.
Trifase: 220-277V/50Hz o 380-480V/50Hz e 220-277V/60Hz o 380-480V/60Hz con protezione da sovraccarico a cura dell'utente.
 - VERSIONI MONOFASI AUTOMATICHE CON GALLEGGIANTE O MANUALI SENZA GALLEGGIANTE.
 - CAVO STANDARD:
Monofase: 10 metri H07RN-F per versione normale (aut.-man.)
5 metri H07RN-F solo per versione automatica. (esclusa TIGER 150)
5 metri H05VV-F solo per TIGER 70.
Trifase: 10 metri H07RN-F
- SPECIALI VOLTAGGI E FREQUENZE A RICHIESTA.

DESIGN ENGINEERING:

- DUAL CHAMBER ELECTRIC PUMP (MECHANICAL SEAL, MOTOR).
 - OIL BATH MOTOR (BIODEGRADABLE AND DIELECTRIC) FOR COOLING AND BEARING LUBRICATION.
 - SEALING RING - ENGINE FACE.
 - OIL BATH MECHANICAL SEALS.
 - PERMISSIBLE DRAUGHT OF WATER: 5 m.
 - IP 68 PROTECTION CLASS.
 - CLASS "F" INSULATION.
 - MAX. PUMPED LIQUID TEMPERATURE:
25°C with PARTIALLY submerged pump.
35°C with TOTALLY submerged pump.
 - BY PASS SECTION: 30 mm - TIGER 70.
35 mm - TIGER 80.
50 mm - TIGER 100 - 150 - 200.
 - VERSIONS: Single Phase: 220-230V/50Hz or 220-230V/60 Hz with built in thermal protection and permanent capacitor.
Three Phases : 220-277V/50 Hz or 380-480V/50Hz and 220-277V/60Hz or 380-480V/60Hz with overload protection care of the User.
 - AUTOMATIC SINGLE PHASE VERSIONS WITH FLOATER OR MANUAL SINGLE PHASE VERSION WITHOUT FLOATER.
 - STANDARD CABLE FEATURES:
Single Phase: 10 metres H07RN-F for the standard version (automatic-manual).
5 metres H07RN-F only for the automatic version. (excluded TIGER 150).
5 metres H05VV-F only for TIGER 70.
Three Phases: 10 metres H07RN-F.
- CUSTOMISED VOLTAGE AND FREQUENCY RATING AVAILABLE ON DEMAND.

TABELLA MATERIALI / MATERIALS TABLE:

Pos.	Componente / Component	Materiale / Materials
A	Carcassa esterna / External housing	ACCIAIO INOX AISI 304-DIN 1.4301 STAINLESS STEEL
B	Girante / Impeller	
C	Albero (lato pompa) Shaft (pump side)	TIGER 70 ACCIAIO INOX AISI 416-DIN 1.4005 / STAINLESS STEEL
		TIGER 80-100-150 ACCIAIO INOX AISI 316-DIN 1.4401 / STAINLESS STEEL
D	Tenuta meccanica Mechanical seal	Lato pompa / Pump face GRAFITE-CERAMICA GRAPHITE-CERAMIC
		Lato motore / Motor face ANELLO DI TENUTA NBR NBR SEAL RING
E	O-ring	NBR
G	Porta motore / Motor holder	ACCIAIO INOX AISI 304-DIN 1.4301 STAINLESS STEEL
I	Coperchio / Cover	
N	Base d'appoggio / Base holder	
P	Corpo pompa / Pump body	GHISA (G20) / CAST IRON

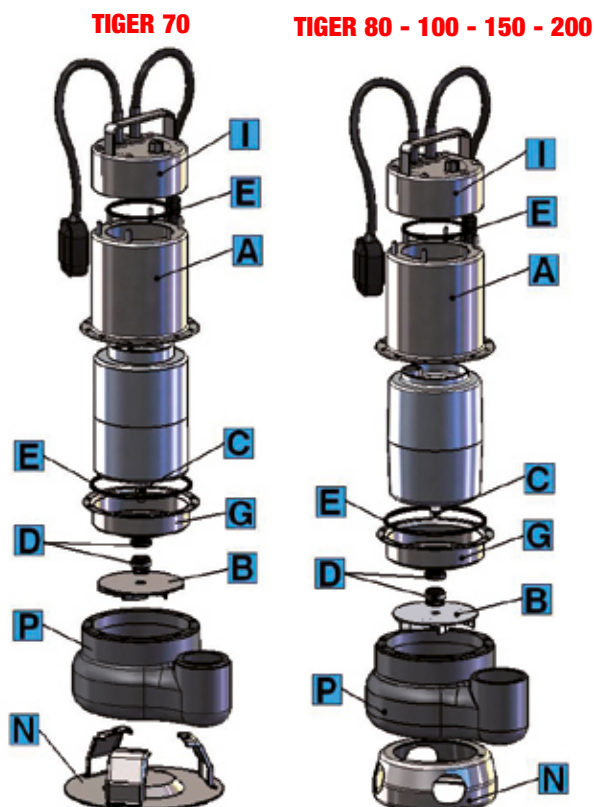

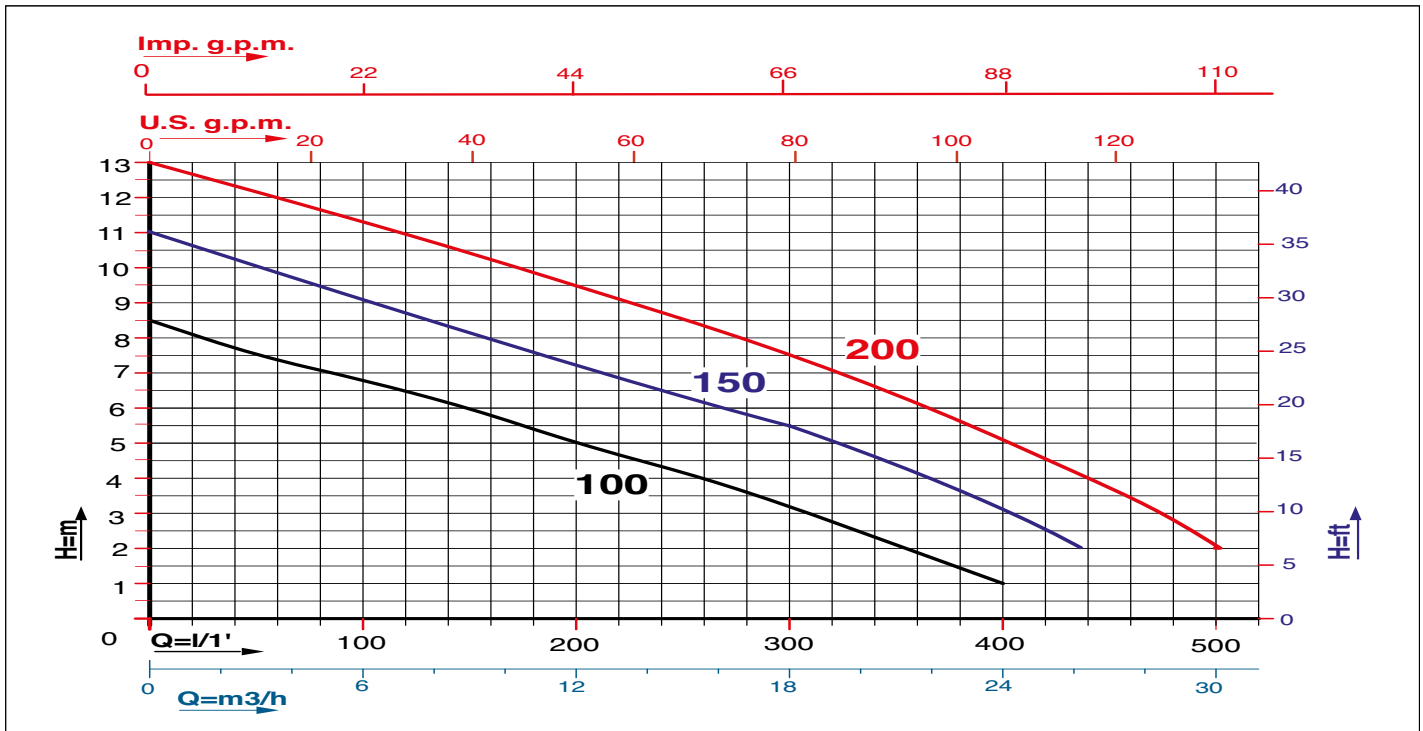
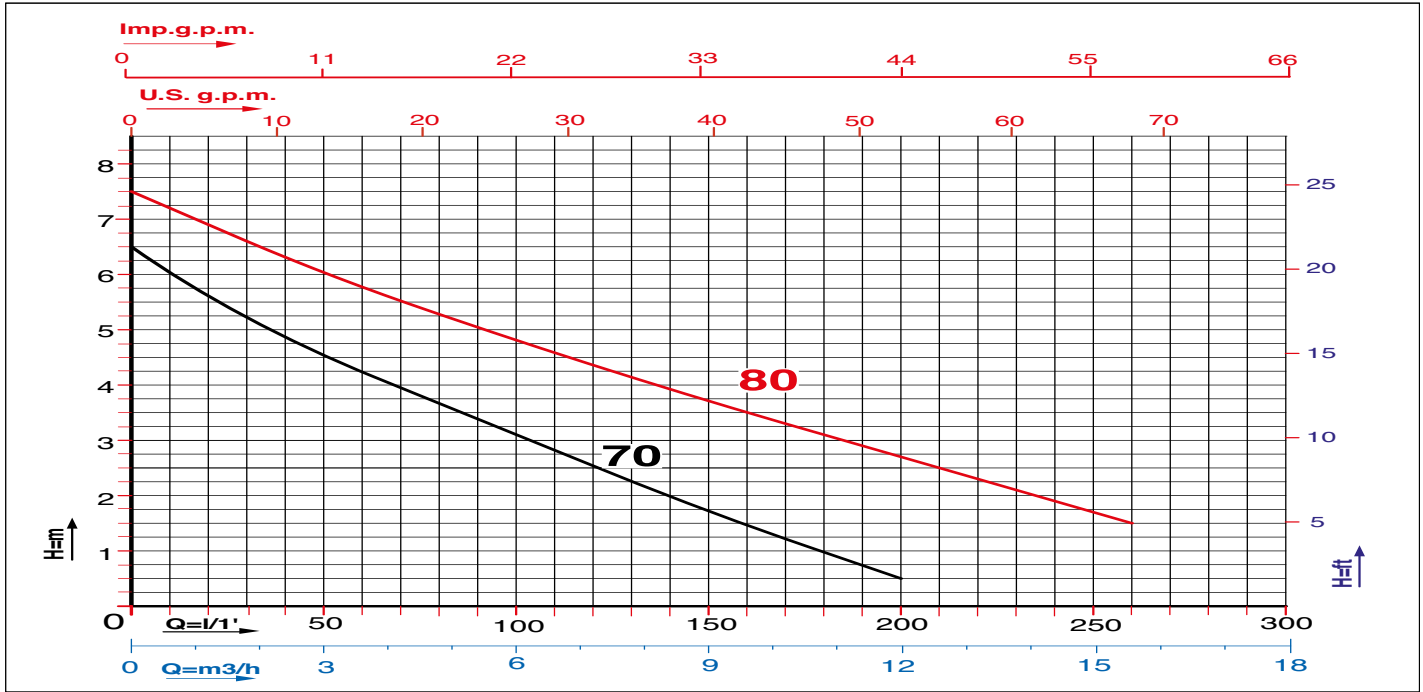

Caratteristiche di funzionamento a 2800 rpm 50Hz e 3450 rpm 60Hz - Performances at 2800 rpm 50 Hz and 3450 rpm 60 Hz
 Le prestazioni valgono per liquidi con densità $\rho = 1,0 \text{ kg/dm}^3$ ed una viscosità $\nu = 1 \text{ mm}^2/\text{s}$ / The performance data holds true for liquids with a $\rho = 1,0 \text{ kg/dm}^3$ density and a $\nu = 1 \text{ mm}^2/\text{s}$ viscosity.

MODELLO MODEL	VOLTAGGIO VOLTAGE	DATI ELETTRICI / ELECTRICAL DATA						DATI IDRAULICI / HYDRAULIC DATA									
		P1max kW	P2 nom.		I max Ampere	Condensatore Capacitor		H (m)									
			kW	HP		µF	VC	0	3	6	9	12	15,6	18	24	27	30
TIGER 70 M	1 x 220-230V	0,9	0,5	0,7	4,0	14,5	450	0	3	6	9	12	15,6	18	24	27	30
TIGER 80 M	1 x 220-230V	1,1	0,6	0,8	5,0	16,0	450	0	3	6	9	12	15,6	18	24	27	30
TIGER 80 T	3 x 380-440V	0,9	0,6	0,8	2,0	---	---	0	3	6	9	12	15,6	18	24	27	30
TIGER 100 M	1 x 220-230V	1,5	0,75	1,0	6,5	20,0	450	0	3	6	9	12	15,6	18	24	27	30
TIGER 100 T	3 x 380-440V	1,3	0,75	1,0	2,4	---	---	0	3	6	9	12	15,6	18	24	27	30
TIGER 150 M	1 x 220-230V	2,2	1,1	1,5	10,4	30,0	450	0	3	6	9	12	15,6	18	24	27	30
TIGER 150 T	3 x 380-440V	1,7	1,1	1,5	3,0	---	---	0	3	6	9	12	15,6	18	24	27	30
TIGER 200 M	1 x 220-230V	2,4	1,5	2,0	11,5	30,0	450	0	3	6	9	12	15,6	18	24	27	30
TIGER 200 T	3 x 380-440V	2,5	1,5	2,0	4,3	---	---	0	3	6	9	12	15,6	18	24	27	30

PREVALENZA TOTALE in METRI COLONNA ACQUA / TOTAL PUMP HEAD AND WATER COLUMN HEIGHT IN m.

CARATTERISTICHE DI COSTRUZIONE:

- ELETTOPOMPA A DOPPIA CAMERA (MOTORE, TENUTA MECCANICA).
 - MOTORE A BAGNO D'OLIO (BIODEGRADABILE E DIELETTRICO) PER RAFFREDDAMENTO E LUBRIFICAZIONE CUSCINETTI.
 - ANELLO DI TENUTA LATO MOTORE.
 - TENUTA MECCANICA A BAGNO D'OLIO.
 - IMMERSIONE MASSIMA: mt. 5.
 - GRADO DI PROTEZIONE IP 68 .
 - CLASSE DI ISOLAMENTO: F.
 - TEMPERATURA MAX. LIQUIDO POMPATO:
25°C con pompa PARZIALMENTE immersa.
35°C con pompa TOTALMENTE immersa.
 - PASSAGGIO LIBERO: 50 mm - TIGER BC 100 - 150 - 200.
 - VERSIONI: Monofase: 220-277V/50Hz e 220-277V/60 Hz con protettore termico incorporato e condensatore permanentemente inserito.
Trifase: 220-277V/50Hz o 380-480V/50Hz e 220-277V/60Hz o 380-480V/60Hz con protezione da sovraccarico a cura dell'utente.
 - VERSIONI MONOFASI AUTOMATICHE CON GALLEGGIANTE O MANUALI SENZA GALLEGGIANTE.
 - CAVO STANDARD:
Monofase: 10 metri H07RN-F per versione normale (aut.-man.).
Trifase: 10 metri H07RN-F.
- SPECIALI VOLTAGGI E FREQUENZE A RICHIESTA.

DESIGN ENGINEERING:

- DUAL CHAMBER ELECTRIC PUMP (mechanical seal, motor).
 - OIL BATH MOTOR (BIODEGRADABLE AND DIELECTRIC) FOR COOLING AND BEARING LUBRICATION.
 - SEALING RING - ENGINE FACE.
 - OIL BATH MECHANICAL SEALS.
 - PERMISSIBLE DRAUGHT OF WATER: 5 m.
 - IP 68 PROTECTION CLASS.
 - CLASS "F" INSULATION.
 - MAX. PUMPED LIQUID TEMPERATURE:
25°C with PARTIALLY submerged pump.
35°C with TOTALLY submerged pump.
 - BY PASS SECTION: 50 mm - TIGER BC 100 - 150 - 200.
 - VERSIONS: Single Phase: 220-277V/50 Hz or 220-277V/60 Hz with built in thermal protection and permanent capacitor.
Three Phases : 220-277V/50 Hz or 380-480V/50Hz and 220-277V/60Hz or 380-480V/60Hz with overload protection care of the User.
 - AUTOMATIC SINGLE PHASE VERSIONS WITH FLOATER OR MANUAL SINGLE PHASE VERSION WITHOUT FLOATER.
 - STANDARD CABLE FEATURES:
Single Phase: 10 metres H07RN-F for the standard version (automatic-manual).
Three Phase: 10 metres H07RN-F.
- CUSTOMISED VOLTAGE AND FREQUENCY RATING AVAILABLE ON DEMAND.

TABELLA MATERIALI / MATERIALS TABLE:

Pos.	Componente / Component	Materiale / Materials	
A	Carcassa esterna / External housing	ACCIAIO INOX AISI 304 DIN 1.4301 STAINLESS STEEL	
B	Girante / Impeller	GHISA (G20) CAST IRON	
C	Albero (lato pompa) / Shaft (pump side)	ACCIAIO INOX AISI 316 DIN 1.4401 STAINLESS STEEL	
D	Tenuta meccanica Mechanical seal	Lato pompa / Pump face	GRAFITE-CERAMICA GRAPHITE-CERAMIC
		Lato motore / Motor face	ANELLO DI TENUTA NBR NBR SEAL RING
E	O-ring	NBR	
G	Porta motore / Motor holder	ACCIAIO INOX AISI 304 DIN 1.4301 STAINLESS STEEL	
I	Coperchio / Cover		
N	Base d'appoggio / Base holder	ACCIAIO INOX AISI 304 DIN 1.4301 STAINLESS STEEL	
P	Corpo pompa / Pump body	GHISA (G20) CAST IRON	

TIGER - BC 100 - 150 - 200



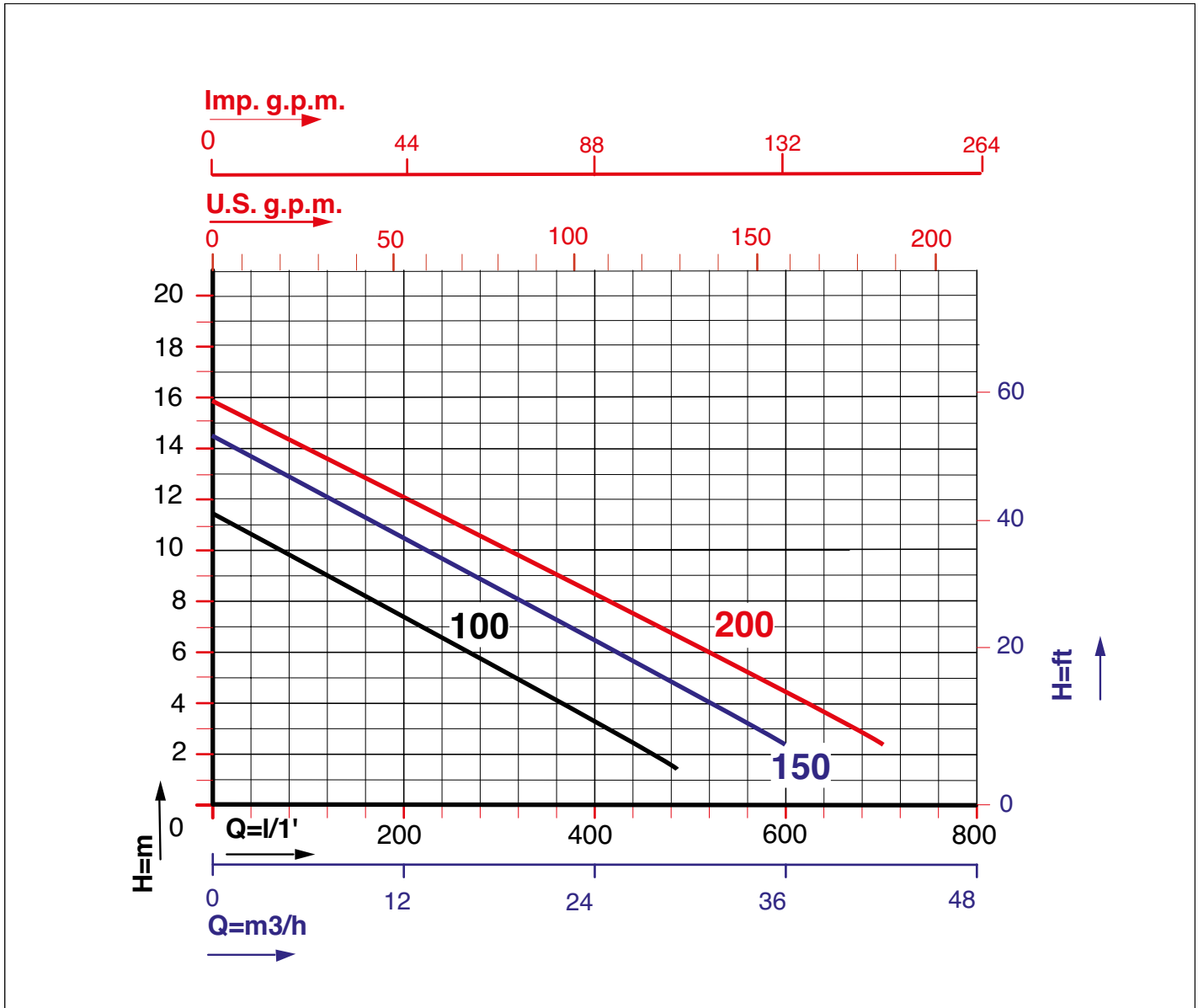

Caratteristiche di funzionamento a 2800 rpm 50Hz e 3450 rpm 60Hz - Performances at 2800 rpm 50 Hz and 3450 rpm 60 Hz
 Le prestazioni valgono per liquidi con densità $\rho = 1,0 \text{ kg/dm}^3$ ed una viscosità $\nu = 1 \text{ mm}^2/\text{s}$ / The performance data holds true for liquids with a $\rho = 1,0 \text{ kg/dm}^3$ density and a $\nu = 1 \text{ mm}^2/\text{s}$ viscosity.

MODELLO MODEL	VOLTAGGIO VOLTAGE	DATI ELETTRICI / ELECTRICAL DATA						DATI IDRAULICI / HYDRAULIC DATA										
		P1 max kW	P2 nom. kW	I max HP	I max Ampere	Condensatore Capacitor		m³/h										
						µF	VC	0	3	6	12	18	24	30	36	42		
	50 Hz							0	50	100	200	300	400	500	600	700		
TIGER - BC 100 M	1 x 220-230V	1,5	0,75	1,0	7,0	20,0	450											
TIGER - BC 100 T	3 x 380-440V	1,3	0,75	1,0	3,2	---	---											
TIGER - BC 150 M	1 x 220-230V	2,2	1,1	1,5	11,5	30,0	450											
TIGER - BC 150 T	3 x 380-440V	1,7	1,1	1,5	4,5	---	---											
TIGER - BC 200 T	3 x 380-440V	2,2	1,5	2,0	4,8	---	---											
								PREVALENZA TOTALE in METRI COLONNA ACQUA / TOTAL PUMP HEAD AND WATER COLUMN HEIGHT IN m.										

DIMENSIONI E PESI / SIZE AND WEIGHT DATA:

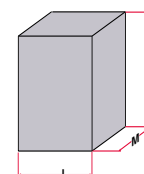
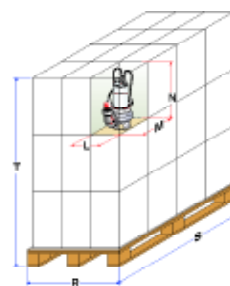
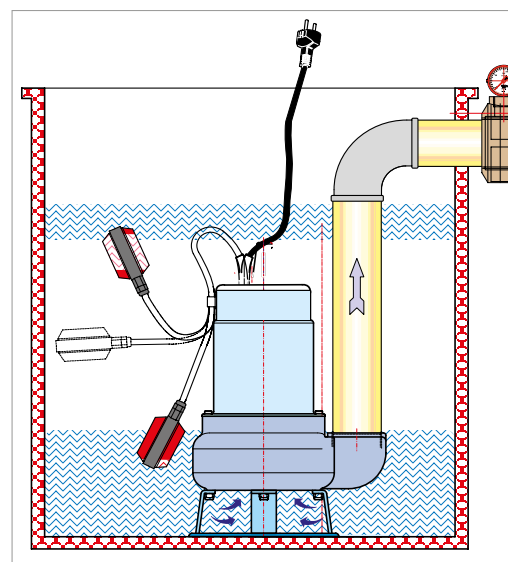
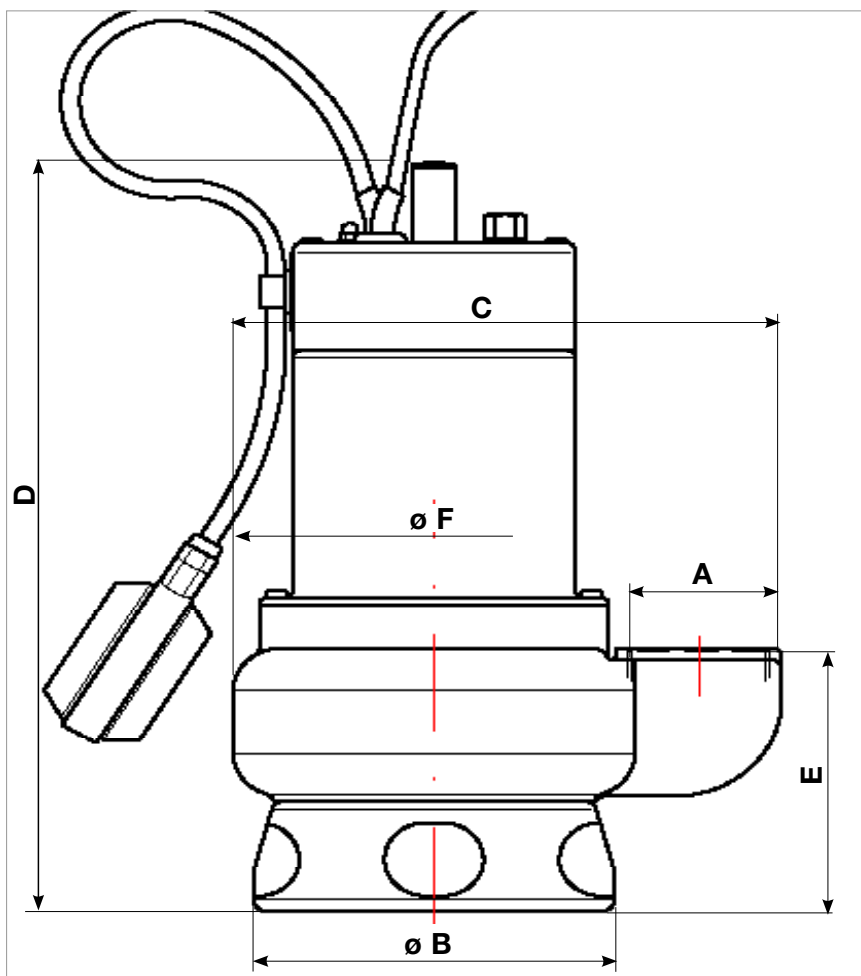

MODELLO / MODEL	DIMENSIONI POMPA in mm. / PUMP DIMENSIONS in mm.					
	A	B	C	D	E	F
TIGER 70	1" 1/2	150	232	360,5	125	170
TIGER 80	1" 1/2	150	232	372,5	125	170
TIGER 100	2"	150	232	385,5	125	170
TIGER 150	2"	150	232	395,5	125	170
TIGER 200	2"	150	232	395,5	125	170
TIGER - BC 100	2"	150	232	367	125	170
TIGER - BC 150	2"	150	232	407	125	170
TIGER - BC 200	2"	150	232	407	125	170

MODELLO / MODEL	DIMENSIONI SCATOLA / PACKING DIMENSIONS				DIMENSIONI PALLET / PALLET DIMENSIONS				
	L mm.	M mm.	N mm.	Peso / Weight Kg.	R mm.	S mm.	T mm.	nr. scatole/cartons	Peso / Weight Kg.
TIGER 70	190	230	410	12,0	800	1200	1360	60	685
TIGER 80	190	230	410	12,5	800	1200	1360	60	745
TIGER 100	190	230	410	13,5	800	1200	1360	60	805
TIGER 150	190	230	480	17,0	800	1200	1570	60	925
TIGER 200	190	230	480	17,1	800	1200	1570	60	925
TIGER BC 100	190	230	480	15,0	800	1200	1570	60	865
TIGER BC 150	190	230	480	17,9	800	1200	1570	60	985
TIGER BC 200	190	230	480	18,3	800	1200	1570	60	985

TIGER F



ELETTROPOMPE SOMMERGIBILI VORTEX PER ACQUE CARICHE, DOTATE DI CONTROFLANGIA **SUBMERSIBLE VORTEX ELECTRIC PUMPS FOR WASTE WATER, FEATURING A COUNTER FLANGE**

PREVALENZA : 7,0 mt. ÷ 15,5 mt.
PORTATA : 15,6 m³/h ÷ 75,0 m³/h
POTENZA NOMINALE : 0,6 kW (0,8HP) ÷ 3,0 kW (4,0HP)
PASSAGGIO SOLIDI FINO A 80 mm.

PUMP HEAD : 7,0 mt ÷ 15,5 mt
DELIVERY : 15,6 m³/h ÷ 75,0 m³/h
RATED HORSEPOWER : 0,6 kW (0,8HP) ÷ 3,0 kW (4,0HP)
SOLID MATTER BYPASS up to 80 mm

APPLICAZIONI

- SVUOTAMENTO DI FOSSE DI DECANTAZIONE, POZZI DI RACCOLTA LIQUAMI.
- POMPAGGIO DI ACQUE LURIDE ANCHE CON CORPI SOLIDI IN SOSPENSIONE.
- MOVIMENTAZIONE DI ACQUE LURIDE AD USO DOMESTICO ED INDUSTRIALE.

APPLICATIONS

- DECANTATION PIT, SEWAGE PIT AND SLURRY COLLECTION PIT PUMP OUT.
- PUMP OUT OF LAVATORY/FOUL WATER WITH POSSIBLE FLOATING SOLIDS CONTENTS.
- DOMESTIC AND INDUSTRIAL LAVATORY/BLACK WATER HANDLING SYSTEMS.

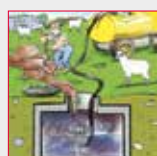
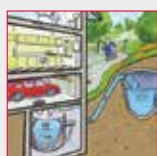

CARATTERISTICHE DI COSTRUZIONE:

- ELETTOPOMPA A DOPPIA CAMERA (MOTORE, TENUTA MECCANICA).
- ELETTOPOMPA A UNICA CAMERA (SOLO PER TIGER 400F).
- MOTORE A BAGNO D'OLIO (BIODEGRADABILE E DIELETTRICO) PER RAFFREDDAMENTO E LUBRIFICAZIONE CUSCINETTI.
- ANELLO DI TENUTA LATO MOTORE.
- TENUTA MECCANICA A BAGNO D'OLIO.
- DOPPIA TENUTA MECCANICA: LATO MOTORE A BAGNO D'OLIO (SOLO PER TIGER 400F) LATO POMPA A BAGNO D'ACQUA
- IMMERSIONE MASSIMA: mt. 5 .
- GRADO DI PROTEZIONE IP 68 .
- CLASSE DI ISOLAMENTO: F
- TEMPERATURA MAX. LIQUIDO POMPATO:
25°C con pompa PARZIALMENTE immersa.
35°C con pompa TOTALMENTE immersa
- PASSAGGIO LIBERO: 35 mm - TIGER 80F
50 mm - TIGER 100F - 140F - 190F
60 mm - TIGER 150F - 200F
80 mm - TIGER 300F - 400F
- VERSIONI: Monofase: 220-277V/50Hz o 220-277V/60Hz con protettore termico incorporato e condensatore permanentemente inserito.
Trifase: 220-277V/50Hz o 380-480V/50Hz e 220-277V/60Hz o 380-480V/60Hz con protezione da sovraccarico a cura dell'utente.
- POTENZA MOTORE: da 0,6 kW (0,8 HP) a 1,5 kW (2 HP) versione mono fase e trifase.
da 2,2 kW (3 HP) a 3 kW (4 HP) solo versione trifase
- VERSIONI MONOFASI AUTOMATICHE fino a 1,1 kW (1,5 HP).
- VERSIONI MONOFASI da 1,5 kW (2 HP) solo manuali senza galleggiante.
- CAVO STANDARD:
Monofase: 10 metri H07RN-F per versione normale (aut.-man.)
5 metri H07RN-F solo per versione automatica
Trifase: 10 metri H07RN-F
SPECIALI VOLTAGGI E FREQUENZE A RICHIESTA.

OPTIONAL:

- SISTEMI DI DISCESA DN50-DN80 PER IMPIANTI FISSI (VEDERE PAGINA 108-109)

DESIGN ENGINEERING:

- DOUBLE CHAMBER ELECTRIC PUMP (MOTOR, MECHANICAL SEAL).
- SINGLE CHAMBER ELECTRIC PUMP (ONLY FOR TIGER 400F).
- OIL BATH MOTOR (BIODEGRADABLE AND DIELECTRIC) FOR COOLING AND BEARING LUBRICATION.
- SEALING RING - ENGINE FACE
- OIL BATH MECHANICAL SEALS.
- DOUBLE MECHANICAL SEALS: ENGINE FACE: OIL BATH (ONLY TIGER 400F) PUMP FACE: WATER BATH
- PERMISSIBLE DRAUGHT OF WATER: 5 m
- IP 68 PROTECTION CLASS.
- CLASS "F" INSULATION.
- MAX. PUMPED ALIQUID TEMPERATURE:
25°C with PARTIALLY submerged pump.
35°C with TOTALLY submerged pump.
- BY PASS SECTION: 35 mm. - TIGER 80F
50 mm - TIGER 100F - 140F - 190F
60 mm - TIGER 150F - 200F
80 mm - TIGER 300F - 400F
- VERSIONS: Single Phase: 220-277V/50Hz or 220-277V/60 Hz with built in thermal protection and permanent capacitor.
Three Phase : 220-277V/50 Hz or 380-480V/50Hz and 220-277V/60Hz or 380-480V/60Hz with overload protection care of the User.
- MOTOR POWER:
From 0,6 kW (0,8 HP) to 1,5 kW (2,0 HP) single phase and three phase versions.
From 2,2 kW (3,0 HP) to 3,0 kW (4,0 HP) only three phase versions
- AUTOMATIC SINGLE PHASE VERSIONS up to 1,1 kW (1,5 HP).
- SINGLE PHASE VERSIONS from 1,5 kW (2 HP) only manual, without floater.
- STANDARD CABLE FEATURES:
Single Phase: 10 metres H07RN-F for the standard version (automatic-manual)
5 metres H07RN-F only for the automatic version.
Three Phase: 10 metres H07RN-F
CUSTOMISED VOLTAGE AND FREQUENCY RATING AVAILABLE ON DEMAND.

OPTIONAL:

- DOWN STROKE GUIDE RAIL SYSTEMS DN50-DN80 (SEE PAGE 108-109)

TABELLA MATERIALI / MATERIALS TABLE:

Pos.	Componente / Component		Materiale / Materials	
A	Carcassa esterna / External housing		ACCIAIO INOX AISI 304 - DIN 1.4301 STAINLESS STEEL	
B	Girante / Impeller			
C	Albero (lato pompa) / Shaft (pump side)		ACCIAIO INOX AISI 316 DIN 1.4401 STAINLESS STEEL	
D	Tenuta meccanica Mechanical Seal	Lato motore Motor face	TIGER 80F-100F-140F 150F-190F-200F-300F	ANELLO DI TENUTA NBR / NBR SEAL RING
			TIGER 400F	GRAFITE - CERAMICA / GRAPHITE - CERAMIC
		Lato pompa Pump face	TIGER 80F-100F-140F-190F	GRAFITE - CERAMICA / GRAPHITE - CERAMIC
			TIGER 150F-200F-300F-400F	CARBURO DI SILICIO - CERAMICA SILICON CARBIDE - CERAMIC
E	Oring		NBR	
H	Carcassa motore / Motor housing		ACCIAIO INOX AISI 304 - DIN 1.4301 STAINLESS STEEL	
I	Coperchio + maniglia / Cover + handle		GHISA (G.20) CAST IRON	
R	Flangia inferiore / Lower flange			
S	Flangia superiore / Upper flange			
P	Corpo pompa / Pump body			
N	Base d'appoggio / Base holder		ACCIAIO INOX AISI 304 - DIN 1.4301 STAINLESS STEEL	
T	Controflangia d'aspirazione / Suction counter-flange			

**TIGER 80F-100F-140F
190F-150F-200F-300F**

TIGER 400F

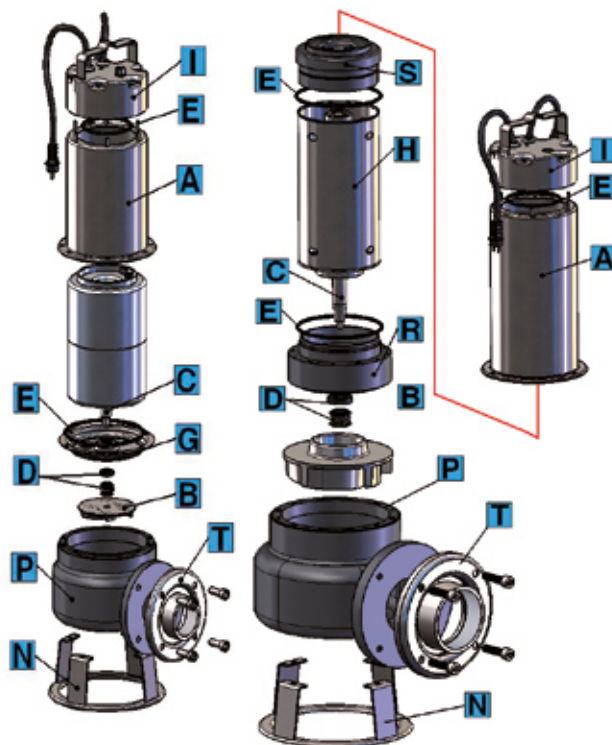

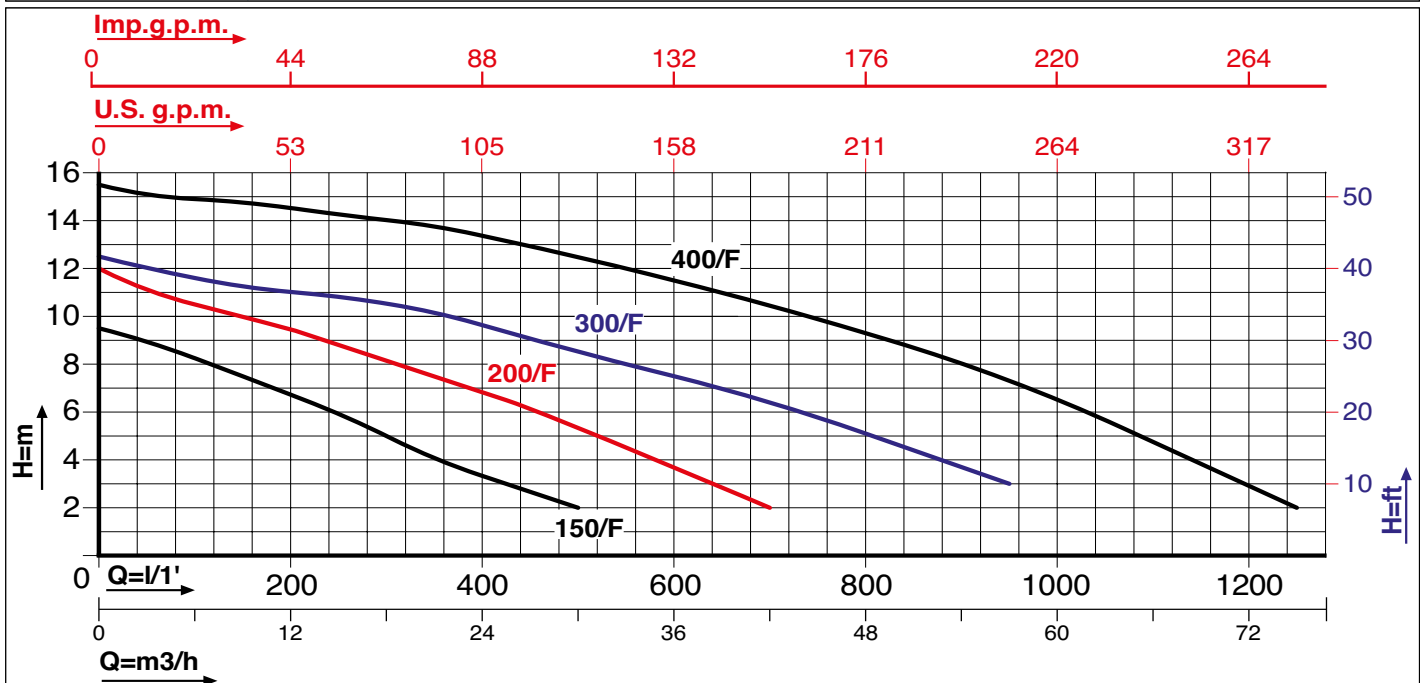
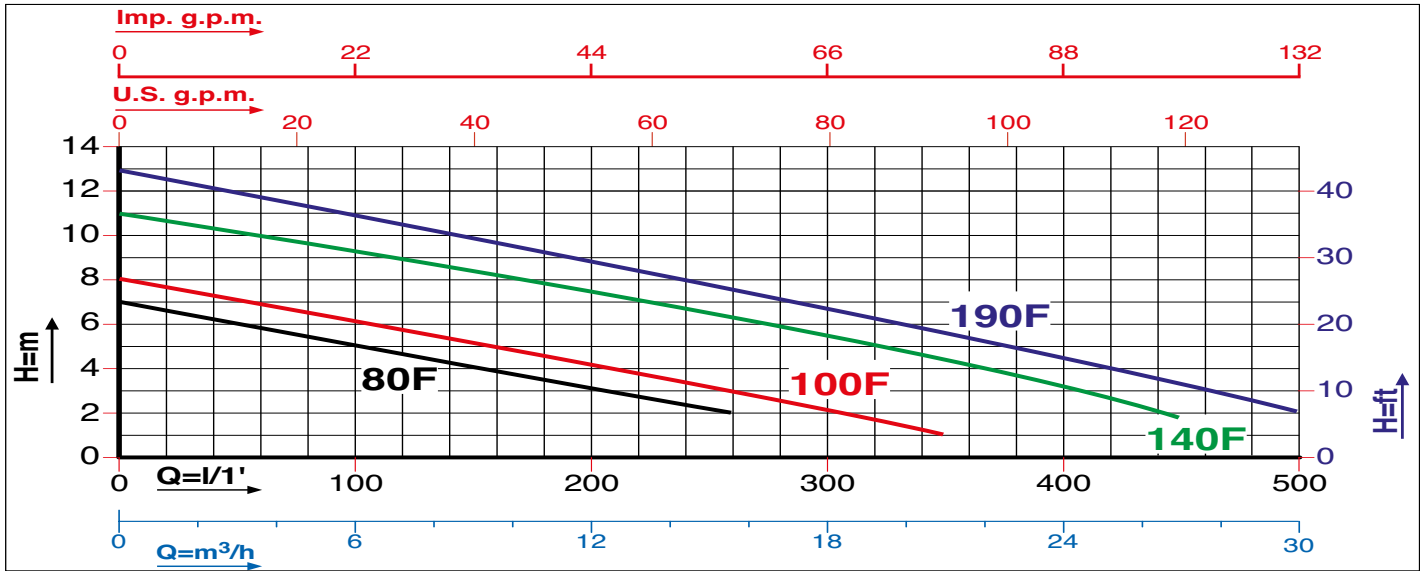

Caratteristiche di funzionamento a 2800 rpm 50Hz e 3450 rpm 60Hz - Performances at 2800 rpm 50 Hz and 3450 rpm 60 Hz
 Le prestazioni valgono per liquidi con densità $\rho = 1,0 \text{ kg/dm}^3$ ed una viscosità $\nu = 1 \text{ mm}^2/\text{s}$ / The performance data holds true for liquids with a $\rho = 1,0 \text{ kg/dm}^3$ density and a $\nu = 1 \text{ mm}^2/\text{s}$ viscosity.

MODELLO MODEL	VOLTAGGIO VOLTAGE	DATI ELETTRICI / ELECTRICAL DATA						DATI IDRAULICI / HYDRAULIC DATA																																																																																																											
		P1 max kW	P2 nom. kW	I max HP	I max Ampere	Condensatore µF	Capacitor VC	m³/h																																																																																																											
								0	9	15,6	21	27	30	42	54	75																																																																																																			
TIGER 80F M	1 x 220-230V	1,1	0,6	0,8	4,5	16,0	450	<table border="1"> <thead> <tr> <th rowspan="2">H (m)</th> <th colspan="9">l/min.</th> </tr> <tr> <th>0</th> <th>150</th> <th>260</th> <th>350</th> <th>450</th> <th>500</th> <th>700</th> <th>900</th> <th>1250</th> </tr> </thead> <tbody> <tr> <td>7,0</td> <td>4,0</td> <td>2,0</td> <td>---</td> <td>---</td> <td>---</td> <td>---</td> <td>---</td> <td>---</td> <td>---</td> </tr> <tr> <td>8,0</td> <td>4,8</td> <td>3,0</td> <td>1,0</td> <td>---</td> <td>---</td> <td>---</td> <td>---</td> <td>---</td> <td>---</td> </tr> <tr> <td>11,0</td> <td>8,0</td> <td>6,2</td> <td>4,5</td> <td>1,8</td> <td>---</td> <td>---</td> <td>---</td> <td>---</td> <td>---</td> </tr> <tr> <td>13,0</td> <td>10,4</td> <td>8,3</td> <td>5,5</td> <td>3,5</td> <td>2,0</td> <td>---</td> <td>---</td> <td>---</td> <td>---</td> </tr> <tr> <td>9,5</td> <td>7,5</td> <td>5,8</td> <td>4,0</td> <td>2,5</td> <td>2,0</td> <td>---</td> <td>---</td> <td>---</td> <td>---</td> </tr> <tr> <td>12,0</td> <td>10,0</td> <td>8,8</td> <td>7,5</td> <td>6,0</td> <td>5,5</td> <td>2,0</td> <td>---</td> <td>---</td> <td>---</td> </tr> <tr> <td>12,5</td> <td>11,2</td> <td>10,8</td> <td>10,2</td> <td>9,0</td> <td>8,5</td> <td>6,5</td> <td>3,0</td> <td>---</td> <td>---</td> </tr> <tr> <td>15,5</td> <td>14,8</td> <td>14,2</td> <td>13,8</td> <td>13,0</td> <td>12,5</td> <td>10,5</td> <td>7,5</td> <td>2,0</td> <td>---</td> </tr> </tbody> </table>									H (m)	l/min.									0	150	260	350	450	500	700	900	1250	7,0	4,0	2,0	---	---	---	---	---	---	---	8,0	4,8	3,0	1,0	---	---	---	---	---	---	11,0	8,0	6,2	4,5	1,8	---	---	---	---	---	13,0	10,4	8,3	5,5	3,5	2,0	---	---	---	---	9,5	7,5	5,8	4,0	2,5	2,0	---	---	---	---	12,0	10,0	8,8	7,5	6,0	5,5	2,0	---	---	---	12,5	11,2	10,8	10,2	9,0	8,5	6,5	3,0	---	---	15,5	14,8	14,2	13,8	13,0	12,5	10,5	7,5	2,0	---
H (m)	l/min.																																																																																																																		
	0	150	260	350	450	500	700										900	1250																																																																																																	
7,0	4,0	2,0	---	---	---	---	---										---	---																																																																																																	
8,0	4,8	3,0	1,0	---	---	---	---										---	---																																																																																																	
11,0	8,0	6,2	4,5	1,8	---	---	---										---	---																																																																																																	
13,0	10,4	8,3	5,5	3,5	2,0	---	---										---	---																																																																																																	
9,5	7,5	5,8	4,0	2,5	2,0	---	---										---	---																																																																																																	
12,0	10,0	8,8	7,5	6,0	5,5	2,0	---										---	---																																																																																																	
12,5	11,2	10,8	10,2	9,0	8,5	6,5	3,0										---	---																																																																																																	
15,5	14,8	14,2	13,8	13,0	12,5	10,5	7,5										2,0	---																																																																																																	
TIGER 80F T	3 x 380-440V	0,9	0,6	0,8	2,0	---	---																																																																																																												
TIGER 100F M	1 x 220-230V	1,5	0,75	1,0	6,5	20,0	450																																																																																																												
TIGER 100F T	3 x 380-440V	1,3	0,75	1,0	2,2	---	---																																																																																																												
TIGER 140F M	1 x 220-230V	2,2	1,1	1,5	10,4	30,0	450																																																																																																												
TIGER 140F T	3 x 380-440V	1,7	1,1	1,5	3,0	---	---																																																																																																												
TIGER 190F M	1 x 220-230V	2,4	1,5	2,0	11,5	30,0	450																																																																																																												
TIGER 190F T	3 x 380-440V	2,2	1,5	2,0	3,6	---	---																																																																																																												
TIGER 150F M	1 x 220-230V	2,1	1,1	1,5	9,5	40,0	450																																																																																																												
TIGER 150F T	3 x 380-440V	1,8	1,1	1,5	3,2	---	---																																																																																																												
TIGER 200F M	1 x 220-230V	2,7	1,5	2,0	12,5	50,0	450																																																																																																												
TIGER 200F T	3 x 380-440V	2,6	1,5	2,0	4,8	---	---																																																																																																												
TIGER 300F T	3 x 380-440V	3,5	2,25	3,0	6,5	---	---																																																																																																												
TIGER 400F T	3 x 380-440V	4,5	3,0	4,0	8,5	---	---																																																																																																												

PREVALENZA TOTALE in METRI COLONNA ACQUA / TOTAL PUMP HEAD AND WATER COLUMN HEIGHT in m.

DIMENSIONI E PESI / SIZE AND WEIGHT DATA:

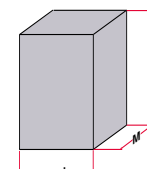
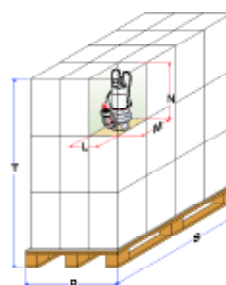
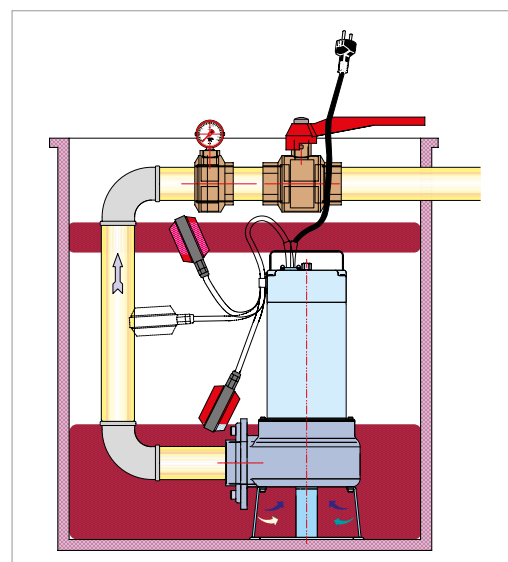
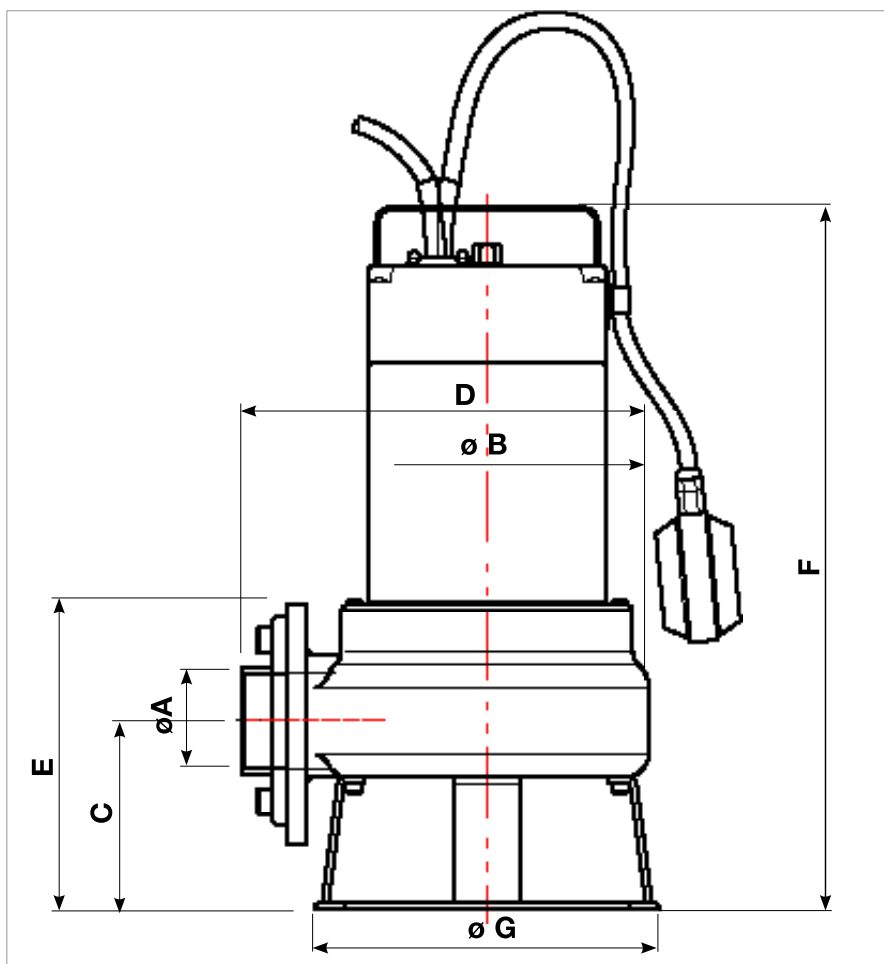

MODELLO / MODEL	DIMENSIONI POMPA in mm. / PUMP DIMENSIONS in mm.						
	A	B	C	D	E	F	G
TIGER 80F	2"	164	81,5	274	161,5	367	153
TIGER 100F	2"	164	81,5	274	161,5	367	153
TIGER 140F	2"	164	81,5	274	161,5	367	153
TIGER 190F	2"	164	81,5	274	161,5	367	153
TIGER 150F	2 1/2"	200	121	280,5	196	490	214
TIGER 200F	2 1/2"	200	121	280,5	196	490	214
TIGER 300F	3"	253	133	290	223	523,5	214
TIGER 400F	3"	253	133	290	223	523,5	214

MODELLO MODEL	DIMENSIONI SCATOLA / PACKING DIMENSIONS				DIMENSIONI PALLET / PALLET DIMENSIONS				
	L mm	M mm	N mm	Peso / Weight Kg	R mm	S mm	T mm	nr. scatole/cartons	Peso / Weight Kg
TIGER 80F	190	230	410	14,0	800	1200	1370	60	865
TIGER 100F	190	230	410	16,0	800	1200	1370	60	985
TIGER 140F	190	230	410	17,0	800	1200	1370	60	1045
TIGER 190F	190	230	410	17,5	800	1200	1370	60	1075
TIGER 150F	260	300	530	23,0	800	1200	1750	36	850
TIGER 200F	260	300	530	28,0	800	1200	1750	36	1030
TIGER 300F	260	300	550	32,0	800	1200	1810	36	1170
TIGER 400F	720	400	260	48,0	800	1200	900	9	460

SKIPPER F



ELETTROPOMPE SOMMERSIBILI VORTEX PER ACQUE CARICHE, DOTATE DI CONTROFLANGIA SUBMERSIBLE VORTEX ELECTRIC PUMPS FOR WASTE WATER, FEATURING A COUNTER FLANGE

PREVALENZA : 7 mt. ÷ 15,5 mt.
PORTATA : 15,6 m³/h ÷ 75 m³/h
POTENZA NOMINALE : 0,6 kW (0,8HP) ÷ 3,0 kW (4HP)
PASSAGGIO SOLIDI FINO A 80 mm.

PUMP HEAD : 7,0 mt ÷ 15,5 mt
DELIVERY : 15,6 m³/h ÷ 75,0 m³/h
RATED HORSEPOWER : 0,6 kW (0,8HP) ÷ 3,0 kW (4,0HP)
SOLID MATTER BYPASS up to 80 mm

APPLICAZIONI

- SVUOTAMENTO DI FOSSE DI DECANTAZIONE, POZZI DI RACCOLTA LIQUAMI.
- POMPAGGIO DI ACQUE LURIDE ANCHE CON CORPI SOLIDI IN SOSPENSIONE.
- MOVIMENTAZIONE DI ACQUE LURIDE AD USO DOMESTICO ED INDUSTRIALE.

APPLICATIONS

- DECANTATION PIT, SLURRY COLLECTION PIT PUMP OUT.
- PUMP OUT OF LAVATORY/FOUL WATER WITH POSSIBLE FLOATING SOLIDS CONTENTS.
- DOMESTIC AND INDUSTRIAL LAVATORY/BLACK WATER HANDLING SYSTEMS.

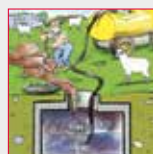

CARATTERISTICHE DI COSTRUZIONE:

- ELETTRROPOMPA A DOPPIA CAMERA (MOTORE, TENUTA MECCANICA).
- ELETTRROPOMPA A UNICA CAMERA (SOLO PER SKIPPER 400F).
- MOTORE A BAGNO D'OLIO (BIODEGRADABILE E DIELETRICO) PER RAFFREDDAMENTO E LUBRIFICAZIONE CUSCINETTI.
- ANELLO DI TENUTA LATO MOTORE.
- TENUTA MECCANICA A BAGNO D'OLIO.
- DOPPIA TENUTA MECCANICA: LATO MOTORE A BAGNO D'OLIO. (SOLO PER SKIPPER 400F) LATO POMPA A BAGNO D'ACQUA.
- IMMERSIONE MASSIMA: mt. 5 .
- GRADO DI PROTEZIONE IP 68 .
- CLASSE DI ISOLAMENTO: F
- TEMPERATURA MAX. LIQUIDO POMPATO:
25°C con pompa PARZIALMENTE immersa.
35°C con pompa TOTALMENTE immersa
- PASSAGGIO LIBERO: 45 mm - SKIPPER 80F - 100F - 140F -190F
60 mm - SKIPPER 150F - 200F
80 mm - SKIPPER 300F - 400F
- VERSIONI: Monofase: 220-277V/50Hz e 220-277V/60Hz con protettore termico incorporato e condensatore permanentemente inserito.
Trifase: 220-277V/50Hz o 380-480V/50Hz e 220-277V/60Hz o 380-480V/60Hz con protezione da sovraccarico a cura dell'utente.
- POTENZA MOTORE: da 0,6 kW (0,8 HP) a 1,5 kW (2 HP) versione monofase e trifase.
da 2,2 kW (3 HP) a 3 kW (4 HP) solo versione trifase
- VERSIONI MONOFASI AUTOMATICHE fino a 1,1 kW (1,5 HP).
- VERSIONI MONOFASI da 1,5 kW (2 HP) solo manuali senza galleggiante.
- CAVO STANDARD:
Monofase: 10 metri H07RN-F per versione normale (aut.-man.)
5 metri H07RN-F solo per versione automatica .
Trifase: 10 metri H07RN-F

SPECIALI VOLTAGGI E FREQUENZE A RICHIESTA.

OPTIONAL:

- SISTEMI DI DISCESA DN50-DN80 PER IMPIANTI FISSI (VEDERE PAGINA 108-109)

DESIGN ENGINEERING:

- DOUBLE CHAMBER ELECTRIC PUMP (MOTOR, MECHANICAL SEAL).
- SINGLE CHAMBER ELECTRIC PUMP (ONLY FOR SKIPPER 400F).
- OIL BATH MOTOR (BIODEGRADABLE AND DIELECTRIC) FOR COOLING AND BEARING LUBRICATION.
- SEALING RING - ENGINE FACE.
- OIL BATH MECHANICAL SEALS.
- DOUBLE MECHANICAL SEALS: ENGINE FACE: OIL BATH. (ONLY SKIPPER 400F) PUMP FACE: WATER BATH.
- PERMISSIBLE DRAUGHT OF WATER: 5 m
- IP 68 PROTECTION CLASS.
- CLASS "F" INSULATION.
- MAX. PUMPED LIQUID TEMPERATURE:
25°C with PARTIALLY submerged pump.
35°C with TOTALLY submerged pump.
- BY PASS SECTION: 45 mm - SKIPPER 80F - 100F - 140F - 190F
60 mm - SKIPPER 150F - 200F
80 mm - SKIPPER 300F - 400F
- VERSIONS: Single Phase: 220-277V/50Hz or 220-277V/60Hz with built in thermal protection and permanent capacitor.
Three Phase : 220-277V/50Hz or 380-480V/50Hz and 220-277V /60Hz or 380-480V/60Hz with overload protection care of the User.
- MOTOR POWER: From 0,6 kW (0,8 HP) to 1,5 kW (2 HP) single phase and three phase versions.
From 2,2 kW (3 HP) to 3 kW (4 HP) Only three phase versions
- AUTOMATIC SINGLE PHASE VERSIONS up to 1,1 kW (1,5 HP).
- SINGLE PHASE VERSIONS from 1,5 kW (2 HP) only manual, without floater
- STANDARD CABLE FEATURES:
Single Phase: 10 metres H07RN-F for the standard version (automatic-manual)
5 metres H07RN-F only for the automatic version.
Three Phase: 10 metres H07RN-F

CUSTOMISED VOLTAGE AND FREQUENCY RATING AVAILABLE ON DEMAND.

OPTIONAL:

- DOWN STROKE GUIDE RAIL SYSTEMS DN50-DN80 FOR FIXED PLANTS (SEE PAGE 108-109)

TABELLA MATERIALI / MATERIALS TABLE:

Pos.	Componente / Component	Materiale / Materials	
A	Carcassa esterna / External housing	ACCIAIO INOX AISI 304 - DIN 1.4301 STAINLESS STEEL	
B	Girante / Impeller		
C	Albero (lato pompa) / Shaft (pump side)	ACCIAIO INOX AISI 316 DIN 1.4401 STAINLESS STEEL	
D	Tenuta meccanica Mechanical Seal	Lato motore Motor face	SKIPPER 80F-100F 150F-200F-300F ANELLO DI TENUTA NBR / NBR SEAL RING
		Lato pompa Pump face	SKIPPER 80F-100F SKIPPER 150F-200F-300F-400F GRAFITE - CERAMICA / GRAPHITE - CERAMIC CARBURO DI SILICIO - CERAMICA SILICON CARBIDE - CERAMIC
E	Oring	NBR	
H	Carcassa motore / Motor housing	ACCIAIO INOX AISI 304 - DIN 1.4301 STAINLESS STEEL	
I	Coperchio + maniglia / Cover + handle		
R	Flangia inferiore / Lower flange	GHISA (G.20) CAST IRON	
S	Flangia superiore / Upper flange		
P	Corpo pompa / Pump body		
N	Base d'appoggio / Base holder	ACCIAIO INOX AISI 304 - DIN 1.4301 STAINLESS STEEL	
T	Controflangia d'aspirazione / Suction counter-flange		

**SKIPPER 80F-100F-140F
150F-190F-200F-300F**

SKIPPER 400F

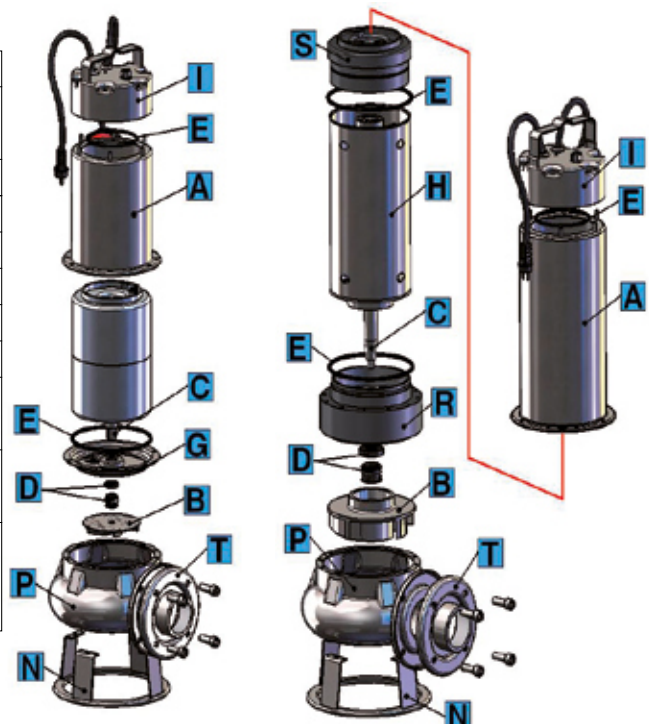

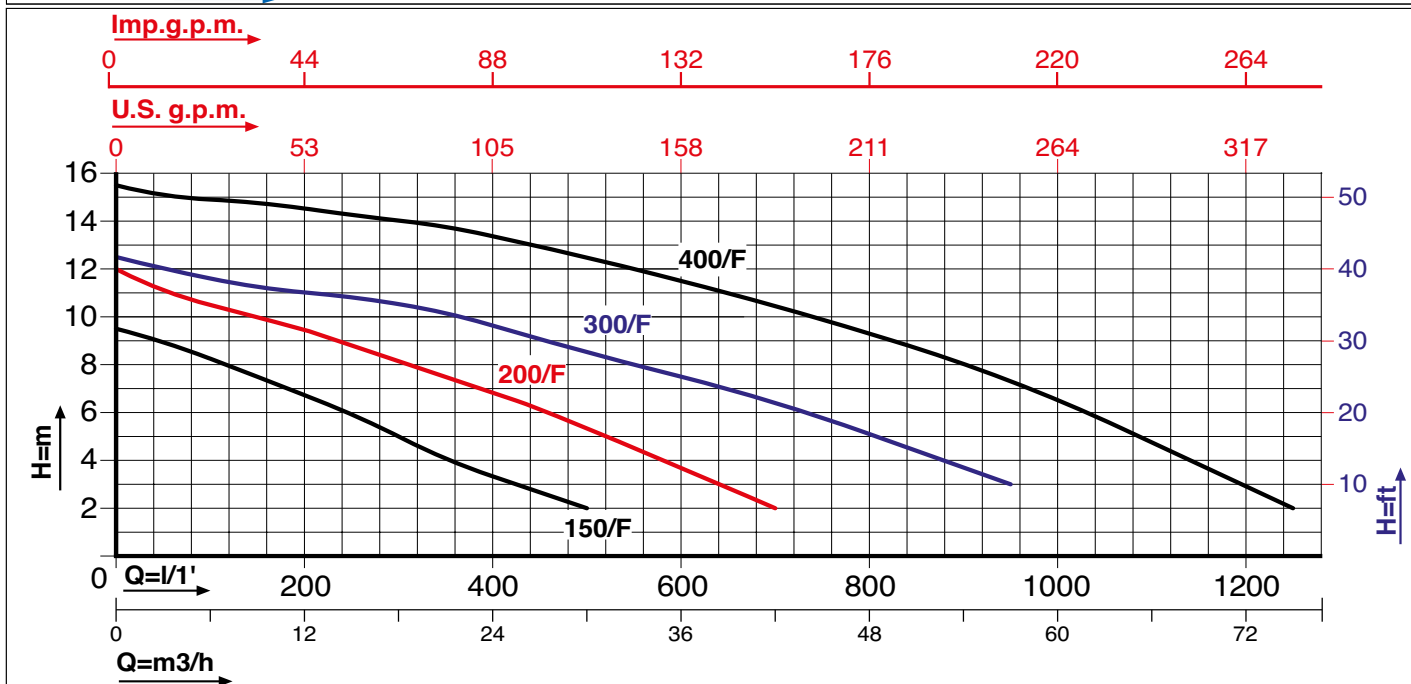
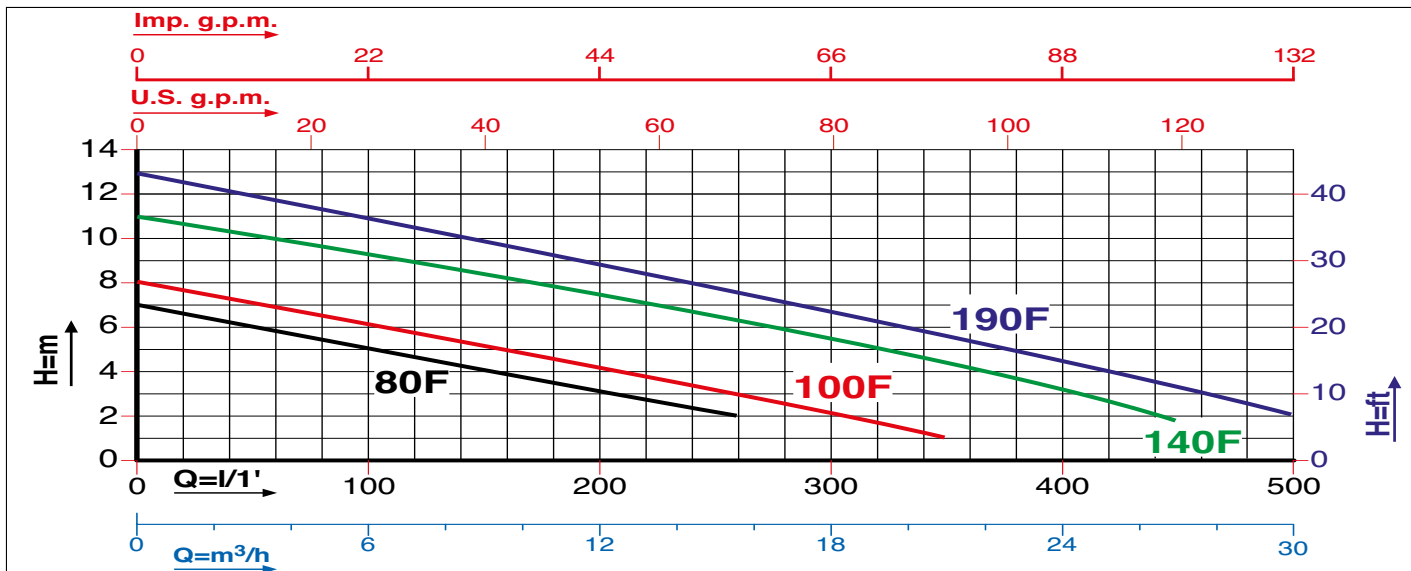

Caratteristiche di funzionamento a 2800 rpm 50Hz e 3450 rpm 60Hz - Performances at 2800 rpm 50 Hz and 3450 rpm 60 Hz
 Le prestazioni valgono per liquidi con densità $p = 1,0 \text{ kg/dm}^3$ ed una viscosità $v = 1 \text{ mm}^2/\text{s}$ / The performance data holds true for liquids with a $p = 1,0 \text{ kg/dm}^3$ density and a $v = 1 \text{ mm}^2/\text{s}$ viscosity.

MODELLO MODEL	VOLTAGGIO VOLTAGE 50 Hz	DATI ELETTRICI / ELECTRICAL DATA						DATI IDRAULICI / HYDRAULIC DATA										
		P1max kW	P2 nom. kW	I max HP	I max Ampere	Condensatore Capacitor μF	VC	m^3/h										
								0	9	15,6	21	27	30	42	54	75		
SKIPPER 80F M	1 x 220-230V	1,1	0,6	0,8	4,5	16,0	450	H (m)	7,0	4,0	2,0	---	---	---	---	---	---	---
SKIPPER 80F T	3 x 380-440V	0,9	0,6	0,8	2,0	---	---		7,0	4,0	2,0	---	---	---	---	---	---	---
SKIPPER 100F M	1 x 220-230V	1,5	0,75	1,0	6,5	20,0	450		8,0	4,8	3,0	1,0	---	---	---	---	---	---
SKIPPER 100F T	3 x 380-440V	1,3	0,75	1,0	2,2	---	---		8,0	4,8	3,0	1,0	---	---	---	---	---	---
SKIPPER 140F M	1 x 220-230V	2,2	1,1	1,5	10,4	30,0	450		11,0	8,0	6,2	4,5	1,8	---	---	---	---	---
SKIPPER 140F T	3 x 380-440V	1,7	1,1	1,5	3,0	---	---		11,0	8,0	6,2	4,5	1,8	---	---	---	---	---
SKIPPER 190F M	1 x 220-230V	2,4	1,5	2,0	11,5	30,0	450		13,0	10,4	8,3	5,5	3,5	2,0	---	---	---	---
SKIPPER 190F T	3 x 380-440V	2,2	1,5	2,0	3,6	---	---		13,0	10,4	8,3	5,5	3,5	2,0	---	---	---	---
SKIPPER 150F M	1 x 220-230V	2,1	1,1	1,5	9,5	40,0	450		9,5	7,5	5,8	4,0	2,5	2,0	---	---	---	---
SKIPPER 150F T	3 x 380-440V	1,8	1,1	1,5	3,2	---	---		9,5	7,5	5,8	4,0	2,5	2,0	---	---	---	---
SKIPPER 200F M	1 x 220-230V	2,7	1,5	2,0	12,5	50,0	450		12,0	10,0	8,8	7,5	6,0	5,5	2,0	---	---	---
SKIPPER 200F T	3 x 380-440V	2,6	1,5	2,0	4,8	---	---		12,0	10,0	8,8	7,5	6,0	5,5	2,0	---	---	---
SKIPPER 300F T	3 x 380-440V	3,5	2,25	3,0	6,5	---	---		12,5	11,2	10,8	10,2	9,0	8,5	6,5	3,0	---	---
SKIPPER 400F T	3 x 380-440V	4,5	3,0	4,0	8,5	---	---		15,5	14,8	14,2	13,8	13,0	12,5	10,5	7,5	2,0	---

PREVALENZA TOTALE in METRI COLONNA ACQUA / TOTAL PUMP HEAD AND WATER COLUMN HEIGHT in m.

DIMENSIONI e PESI / SIZE AND WEIGHT DATA:

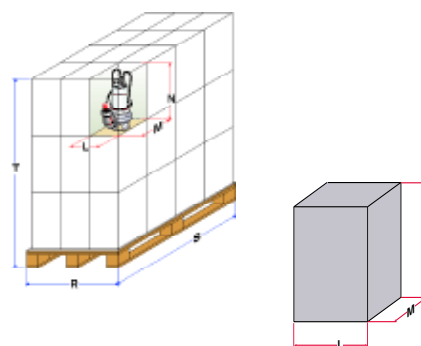
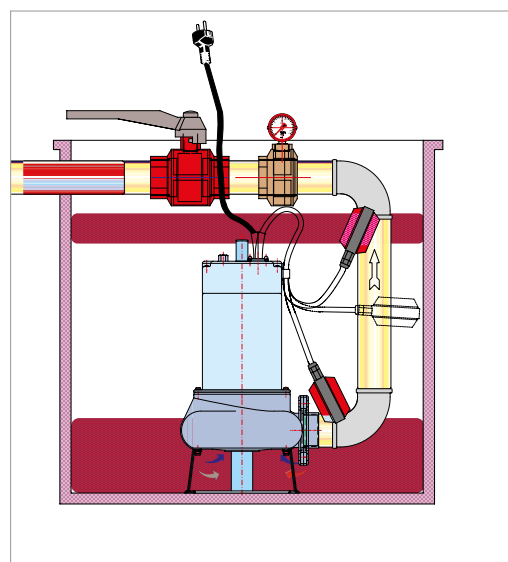
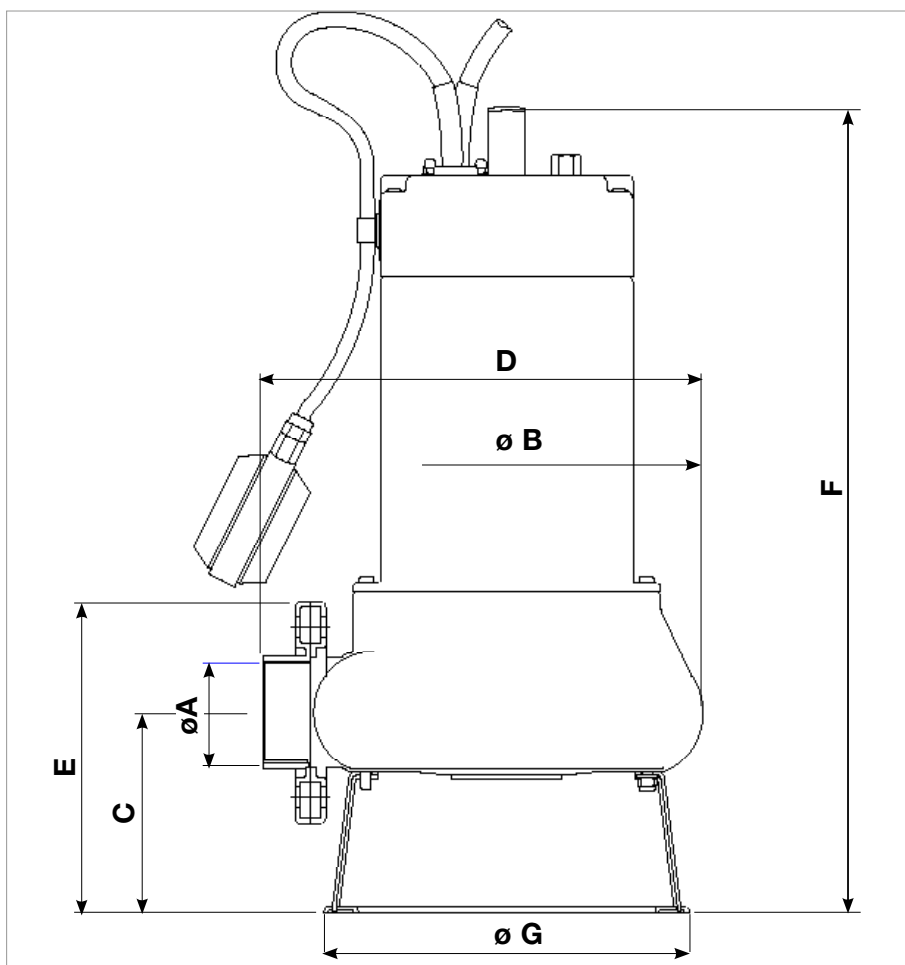

MODELLO MODEL	DIMENSIONI POMPA in mm. / PUMP DIMENSIONS in mm.						
	A	B	C	D	E	F	G
SKIPPER 80F	2"	164	108	217	155	381	180
SKIPPER 100F	2"	164	108	217	155	381	180
SKIPPER 140F	2 1/2"	253	116,5	260	192	473	214
SKIPPER 150F	2 1/2"	253	116,5	260	192	473	214
SKIPPER 190F	2 1/2"	253	116,5	260	192	473	214
SKIPPER 200F	2 1/2"	253	116,5	260	192	473	214
SKIPPER 300F	3"	253	127	278	217	515	214
SKIPPER 400F	3"	253	127	278	217	641	214

MODELLO MODEL	DIMENSIONI SCATOLA / PACKING DIMENSIONS				DIMENSIONI PALLET / PALLET DIMENSIONS				
	L mm	M mm	N mm	Peso/Weight Kg	R mm	S mm	T mm	nr. scatole/cartons	Peso/Weight Kg
SKIPPER 80F	190	230	410	10,5	800	1200	1370	60	655
SKIPPER 100F	190	230	410	11,5	800	1200	1370	60	715
SKIPPER 140F	260	300	530	18,5	800	1200	1750	36	691
SKIPPER 150F	260	300	530	19,0	800	1200	1750	36	709
SKIPPER 190F	260	300	530	22,0	800	1200	1750	36	817
SKIPPER 200F	260	300	530	22,5	800	1200	1750	36	835
SKIPPER 300F	260	300	550	23,0	800	1200	1810	36	850
SKIPPER 400F	720	400	260	39,0	800	1200	900	9	380

SKIPPER



ELETTROPOMPE SOMMERSIBILI VORTEX PER ACQUE CARICHE SUBMERSIBLE VORTEX ELECTRIC PUMPS FOR WASTEWATER

PREVALENZA : 7,5 mt. ÷ 13,0 mt.
PORTATA : 15,6 m³/h ÷ 30,0 m³/h
POTENZA NOMINALE : 0,6 kW (0,8HP) ÷ 1,5 kW (2,0HP)
PASSAGGIO SOLIDI FINO A 50 mm.

APPLICAZIONI

- SVUOTAMENTO DI FOSSE DI DECANTAZIONE, POZZI NERI, POZZI DI RACCOLTA LIQUAMI.
- POMPAGGIO DI ACQUE LURIDE ANCHE CON CORPI SOLIDI IN SOSPENSIONE.
- MOVIMENTAZIONE DI ACQUE LURIDE AD USO DOMESTICO ED INDUSTRIALE.

PUMP HEAD : 7,5 mt ÷ 13,0 mt
DELIVERY : 15,6 m³/h ÷ 30,0 m³/h
RATED HORSEPOWER : 0,6 kW (0,8HP) ÷ 1,5 kW (2,0HP)
SOLID MATTER BYPASS up to 50 mm

APPLICATIONS

- DECANTATION PIT, SEWAGE PIT AND SLURRY COLLECTION PIT PUMP OUT.
- PUMP OUT OF LAVATORY/FOUL WATER WITH POSSIBLE FLOATING SOLIDS CONTENTS.
- DOMESTIC AND INDUSTRIAL LAVATORY/BLACK WATER HANDLING SYSTEMS.

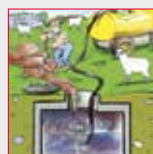

CARATTERISTICHE DI COSTRUZIONE:

- ELETTOPOMPA A DOPPIA CAMERA (MOTORE, TENUTA MECCANICA).
- MOTORE A BAGNO D'OLIO (BIODEGRADABILE E DIELETTRICO) PER RAFFREDDAMENTO E LUBRIFICAZIONE CUSCINETTI.
- ANELLO DI TENUTA LATO MOTORE.
- TENUTA MECCANICA A BAGNO D'OLIO.
- IMMERSIONE MASSIMA: mt. 5.
- GRADO DI PROTEZIONE IP 68.
- CLASSE DI ISOLAMENTO: F.
- TEMPERATURA MAX. LIQUIDO POMPATO:
25°C con pompa PARZIALMENTE immersa.
35°C con pompa TOTALMENTE immersa.
- PASSAGGIO LIBERO: 35 mm - SKIPPER 80.
50 mm - SKIPPER 100 - 150 - 200.
- VERSIONI: Monofase: 220-277V/50Hz e 220-277V/60Hz con protettore termico incorporato e condensatore permanentemente inserito.
Trifase: 220-277V/50Hz o 380-480V/50Hz e 220-277V/60Hz o 380-480V/60Hz con protezione da sovraccarico a cura dell'utente.
- VERSIONI MONOFASI AUTOMATICHE CON GALLEGGIANTE O MANUALI SENZA GALLEGGIANTE.
- CAVO STANDARD:
Monofase: 10 metri H07RN-F per versione normale (aut.-man.).
Trifase: 10 metri H07RN-F.

SPECIALI VOLTAGGI E FREQUENZE A RICHIESTA.

DESIGN ENGINEERING:

- DOUBLE CHAMBER ELECTRIC PUMP (MOTOR, MECHANICAL SEAL).
- OIL BATH MOTOR (BIODEGRADABLE AND DIELECTRIC) FOR COOLING AND BEARING LUBRICATION.
- SEALING RING - ENGINE FACE.
- OIL BATH MECHANICAL SEALS.
- PERMISSIBLE DRAUGHT OF WATER: 5 m.
- IP 68 PROTECTION CLASS.
- CLASS "F" INSULATION.
- MAX. PUMPED LIQUID TEMPERATURE:
25°C with PARTIALLY submerged pump.
35°C with TOTALLY submerged pump.
- BY PASS SECTION: 35 mm - SKIPPER 80.
50 mm - SKIPPER 100 - 150 - 200.
- VERSIONS: Single Phase: 220-277V/50Hz or 220-277V/60 Hz with built in thermal protection and permanent capacitor.
Three Phase :220-277V/50Hz or 380-480V/50Hz and 220-277V/60Hz or 380-480V/60Hz with overload protection care of the User
- AUTOMATIC SINGLE PHASE VERSIONS WITH FLOATER OR MANUAL SINGLE PHASE VERSIONS, WITHOUT FLOATER.
- STANDARD CABLE FEATURES:
Single Phase:10 metres H07RN-F for the standard version (automatic-manual).
Three Phase: 10 metres H07RN-F.

CUSTOMISED VOLTAGE AND FREQUENCY RATING AVAILABLE ON DEMAND.

TABELLA MATERIALI / MATERIALS TABLE:

Pos.	Componente / Component	Materiale / Materials	
A	Carcassa esterna / External housing	ACCIAIO INOX AISI 304 - DIN 1.4301 STAINLESS STEEL	
B	Girante / Impeller		
C	Albero (lato pompa) / Shaft (pump side)	ACCIAIO INOX AISI 316 - DIN 1.4401 STAINLESS STEEL	
D	Tenuta meccanica Mechanical seal	Lato pompa / Pump side	GRAFITE-CERAMICA GRAPHITE-CERAMIC
		Lato motore / Motor side	ANELLO DI TENUTA NBR NBR SEAL RING
E	O-ring	NBR	
G	Porta motore / Motor holder	ACCIAIO INOX AISI 304 - DIN 1.4301 STAINLESS STEEL	
I	Coperchio + maniglia / Cover + handle		
N	Base d'appoggio / Base holder		
P	Corpo pompa / Pump body		

SKIPPER 80 - 100 - 150 - 200

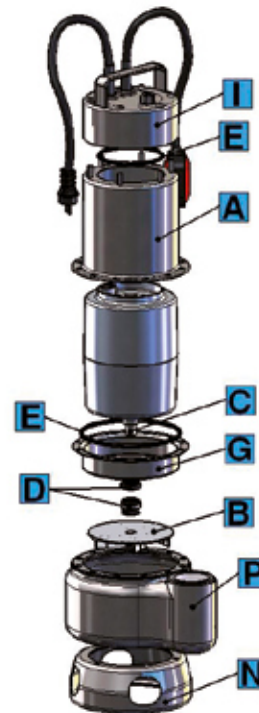

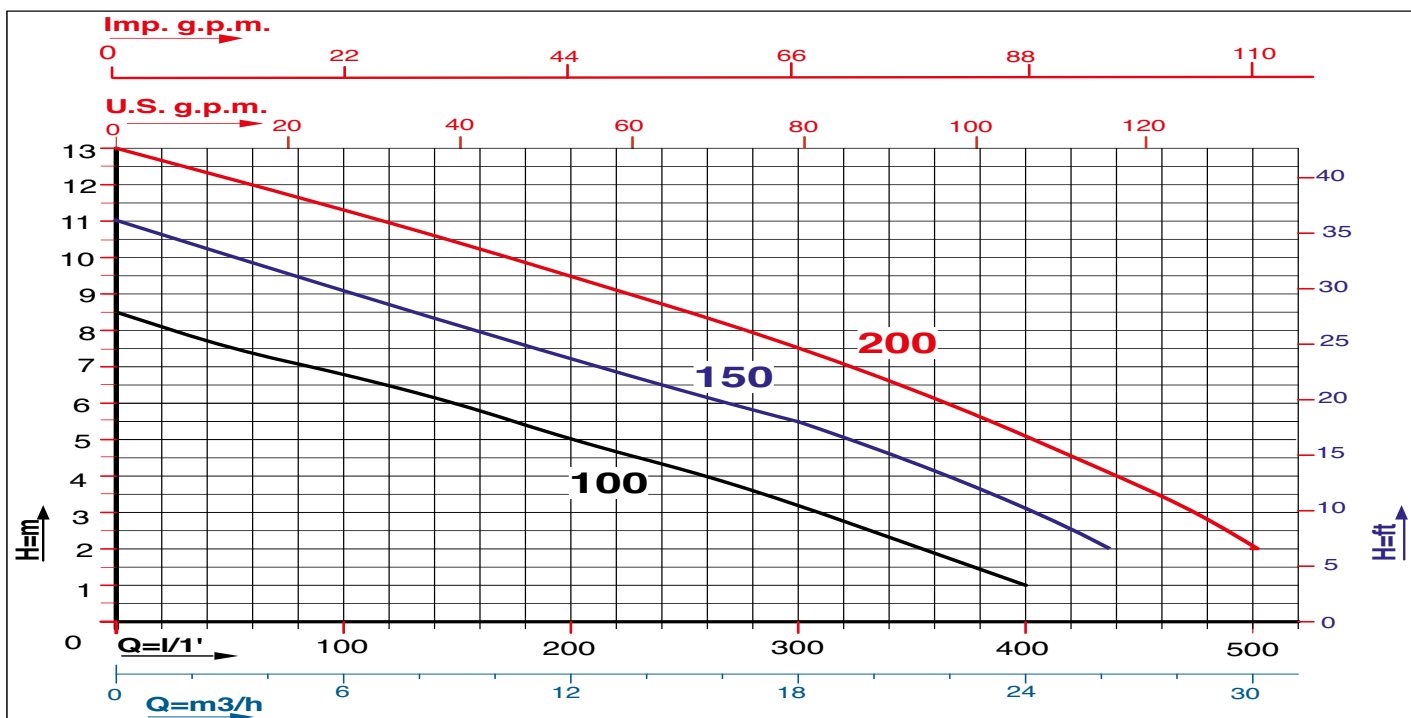
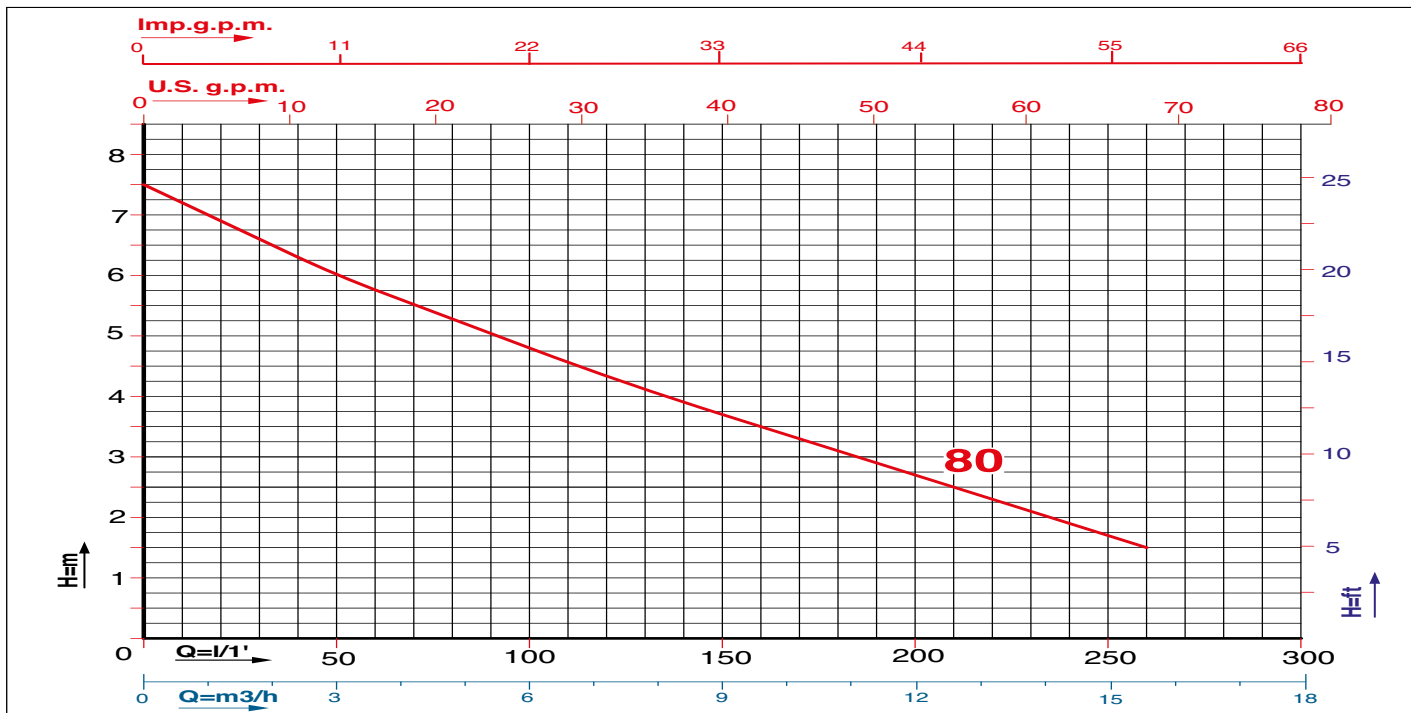

Caratteristiche di funzionamento a 2800 rpm 50Hz e 3450 rpm 60Hz - Performances at 2800 rpm 50 Hz and 3450 rpm 60 Hz
 Le prestazioni valgono per liquidi con densità $\rho = 1,0 \text{ kg/dm}^3$ ed una viscosità $\nu = 1 \text{ mm}^2/\text{s}$ / The performance data holds true for liquids with a $\rho = 1,0 \text{ kg/dm}^3$ density and a $\nu = 1 \text{ mm}^2/\text{s}$ viscosity.

MODELLO MODEL	VOLTAGGIO VOLTAGE	DATI ELETTRICI / ELECTRICAL DATA						DATI IDRAULICI / HYDRAULIC DATA											
		P1max		P2 nom.		I max	Condensatore Capacitor	H (m)											
		kW	kW	HP	Ampere	μF		VC	m³/h	0	3	6	9	12	15,6	18	24	27	30
SKIPPER 80 M	1 x 220-230V	1,1	0,6	0,8	5,0	16,0	450	H (m)	7,5	6,0	4,8	3,7	2,7	1,5	---	---	---	---	---
SKIPPER 80 T	3 x 380-440V	0,9	0,6	0,8	2,0	---	---		7,5	6,0	4,8	3,7	2,7	1,5	---	---	---	---	---
SKIPPER 100 M	1 x 220-230V	1,5	0,75	1,0	6,5	20,0	450		8,5	7,5	6,8	6,0	5,0	4,0	3,2	1,0	---	---	---
SKIPPER 100 T	3 x 380-440V	1,3	0,75	1,0	2,4	---	---		8,5	7,5	6,8	6,0	5,0	4,0	3,2	1,0	---	---	---
SKIPPER 150 M	1 x 220-230V	2,2	1,1	1,5	10,4	30,0	450		11,0	9,8	9,0	8,0	7,3	6,2	5,6	3,2	1,8	---	---
SKIPPER 150 T	3 x 380-440V	1,7	1,1	1,5	3,0	---	---		11,0	9,8	9,0	8,0	7,3	6,2	5,6	3,2	1,8	---	---
SKIPPER 200 M	1 x 220-230V	2,4	1,5	2,0	11,5	30,0	450		13,0	12,2	11,2	10,4	9,5	8,3	7,5	5,2	3,0	2,0	---
SKIPPER 200 T	3 x 380-440V	2,2	1,5	2,0	3,6	---	---		13,0	12,2	11,2	10,4	9,5	8,3	7,5	5,2	3,0	2,0	---

PREVALENZA TOTALE in METRI COLONNA ACQUA / TOTAL PUMP HEAD AND WATER COLUMN HEIGHT IN m.

DIMENSIONI E PESI / SIZE AND WEIGHT DATA:

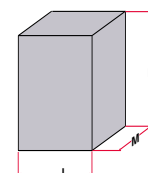
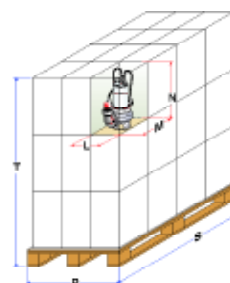
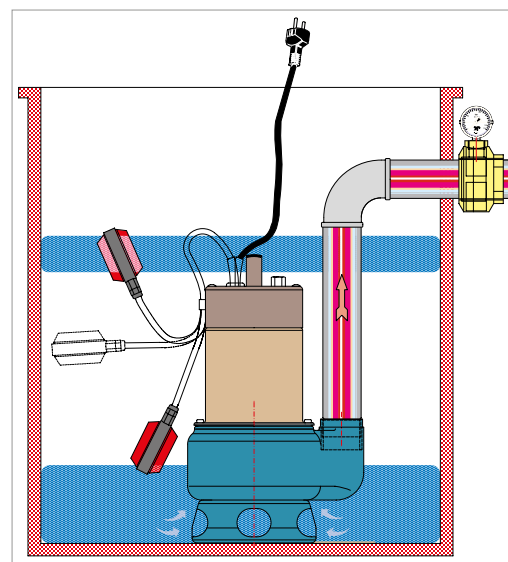
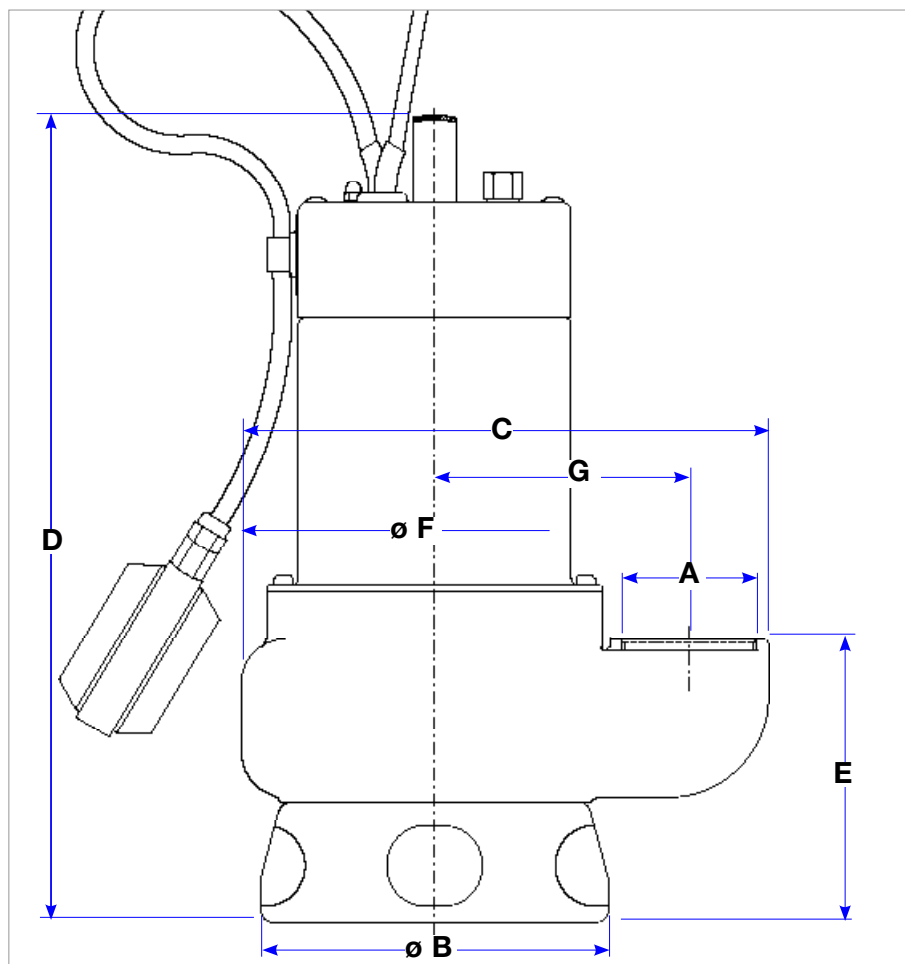

MODELLO / MODEL	DIMENSIONI POMPA in mm. / PUMP DIMENSIONS in mm.						
	A	B	C	D	E	F	G
SKIPPER 80	1" 1/2	164	217	355	153	164	108
SKIPPER 100	1" 1/2	164	217	355	153	164	108
SKIPPER 150	2"	164	221	395	178	164	108
SKIPPER 200	2"	164	221	395	178	164	108

MODELLO MODEL	DIMENSIONI SCATOLA / PACKING DIMENSIONS				DIMENSIONI PALLET / PALLET DIMENSIONS				
	L mm	M mm	N mm	Peso / Weight Kg	R mm	S mm	T mm	nr. scatole/cartons	Peso / Weight Kg
SKIPPER 80	190	230	410	10,5	800	1200	1360	60	650
SKIPPER 100	190	230	410	11,5	800	1200	1360	60	715
SKIPPER 150	190	230	410	13,5	800	1200	1360	60	835
SKIPPER 200	190	230	410	13,5	800	1200	1360	60	835

ARVEX/S aisi 316



ELETTROPOMPE SOMMERSIBILI VORTEX E BICANALI PER ACQUE CARICHE E LIQUIDI AGGRESSIVI SUBMERSIBLE VORTEX AND BICANAL ELECTRIC PUMPS FOR WASTEWATER AND AGGRESSIVE LIQUIDS

PREVALENZA : 10,5 m ÷ 16,0 m
PORTATA : 13,8 m³/h ÷ 42 m³/h
POTENZA NOMINALE : 0,6 kW (0,8HP) ÷ 2,2 kW (2HP)
PASSAGGIO SOLIDI FINO A 50 mm.

APPLICAZIONI

- SVUOTAMENTO DI FOSSE DI DECANTAZIONE, POZZI NERI, POZZI DI RACCOLTA LIQUAMI.
- POMPAGGIO DI ACQUE LURIDE ANCHE CON CORPI SOLIDI IN SOSPENSIONE.
- MOVIMENTAZIONE DI ACQUE LURIDE AD USO DOMESTICO ED INDUSTRIALE.
- POMPAGGIO DI LIQUIDI AGGRESSIVI.

PUMP HEAD : 10,5 mt ÷ 16,0 mt
DELIVERY : 13,8 m³/h ÷ 42,0 m³/h
RATED HORSEPOWER : 0,6 kW (0,8HP) ÷ 2,2 kW (2,0HP)
SOLID MATTER BYPASS up to 50 mm.

APPLICATIONS

- DECANTATION PIT, SEWAGE PIT AND SLURRY COLLECTION PIT PUMP OUT.
- PUMP OUT OF LAVATORY/FOUL WATER WITH POSSIBLE FLOATING SOLIDS CONTENTS.
- DOMESTIC AND INDUSTRIAL LAVATORY/BLACK WATER HANDLING SYSTEMS.
- PUMPING OF AGGRESSIVE MEDIA.

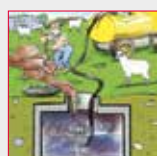

CARATTERISTICHE DI COSTRUZIONE:

- ELETTOPOMPA A DOPPIA CAMERA (MOTORE, TENUTA MECCANICA).
- MOTORE A BAGNO D'OLIO (BIODEGRADABILE E DIELETTRICO) PER RAFFREDDAMENTO E LUBRIFICAZIONE CUSCINETTI.
- ANELLO DI TENUTA LATO MOTORE.
- TENUTA MECCANICA A BAGNO D'OLIO.
- IMMERSIONE MASSIMA: mt. 5 .
- GRADO DI PROTEZIONE IP 68 .
- CLASSE DI ISOLAMENTO: F
- TEMPERATURA MAX. LIQUIDO POMPATO:
25°C con pompa PARZIALMENTE immersa.
35°C con pompa TOTALMENTE immersa.
- PASSAGGIO LIBERO: 30 mm - ARVEX 80 S.
50 mm - ARVEX 100 S - 150 S.
- VERSIONI:
Monofase: 220-277V/50Hz o 220-277V/60Hz con protettore termico incorporato e condensatore permanentemente inserito.
Trifase: 220-277V/50Hz o 380-480V/50Hz e 220-277V/60Hz o 380-480V/60Hz con protezione da sovraccarico a cura dell'utente.
- VERSIONI MONOFASI AUTOMATICHE CON GALLEGGIANTE O MANUALI SENZA GALLEGGIANTE.
- CAVO STANDARD:
Monofase: 10 metri H05VV-F per versione normale (aut.-man.).
Trifase: 10 metri H05VV-F.

SPECIALI VOLTAGGI E FREQUENZE A RICHIESTA.

DESIGN ENGINEERING:

- DOUBLE CHAMBER ELECTRIC PUMP (MOTOR, MECHANICAL SEAL).
- OIL BATH MOTOR (BIODEGRADABLE AND DIELECTRIC) FOR COOLING AND BEARING LUBRICATION.
- SEALING RING - ENGINE FACE
- OIL BATH MECHANICAL SEALS.
- PERMISSIBLE DRAUGHT OF WATER: 5 m.
- IP 68 PROTECTION CLASS.
- CLASS "F" INSULATION.
- MAX. PUMPED LIQUID TEMPERATURE:
25°C with PARTIALLY submerged pump.
35°C with TOTALLY submerged pump.
- BY PASS SECTION: 30 mm - ARVEX 80 S.
50 mm - ARVEX 100 S - 150 S.
- VERSIONS:
Single Phase: 220-277V/50Hz or 220-277V/60 Hz with built in thermal protection and permanent capacitor.
Three Phase: 220-277V/50Hz or 380-480V/50Hz and 220-277V/60Hz or 380-480V/60Hz with overload protection care of the User.
- AUTOMATIC SINGLE PHASE VERSIONS WITH FLOATER OR MANUAL WITHOUT FLOATER.
- STANDARD CABLE FEATURES:
Single Phase: 10 metres H05VV-F for the standard version (automatic-manual).
Three Phase: 10 metres H05VV-F.

CUSTOMISED VOLTAGE AND FREQUENCY RATING AVAILABLE ON DEMAND.

TABELLA MATERIALI / MATERIALS TABLE:

Pos.	Componente / Component		Materiale / Materials
A	Carcassa esterna / External housing		ACCIAIO INOX AISI 316 DIN 1.4401 STAINLESS STEEL
B	Girante / Impeller		
C	Albero (lato pompa) / Shaft (pump side)		
D	Tenuta meccanica Mechanical seal	Lato pompa / Pump face	CARBURO DI SILICIO-VITON SILICON CARBIDE-VITON
		Lato motore / Motor face	ANELLO DI TENUTA NBR NBR SEAL RING
E	O-ring		VITON
G	Porta motore / Motor holder		ACCIAIO INOX AISI 316 DIN 1.4401 STAINLESS STEEL
I	Coperchio + maniglia / Cover + handle		
N	Base d'appoggio / Base holder		
P	Corpo pompa / Pump body		

ARVEX 80/S - 100/S - 150/S - 200/S

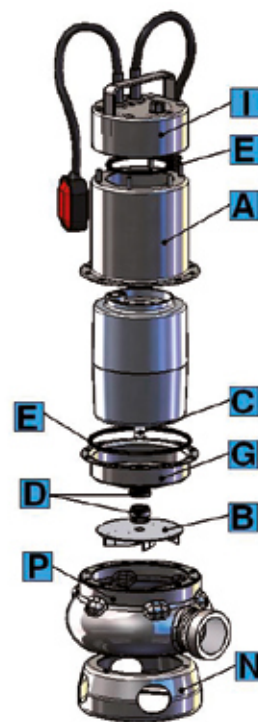

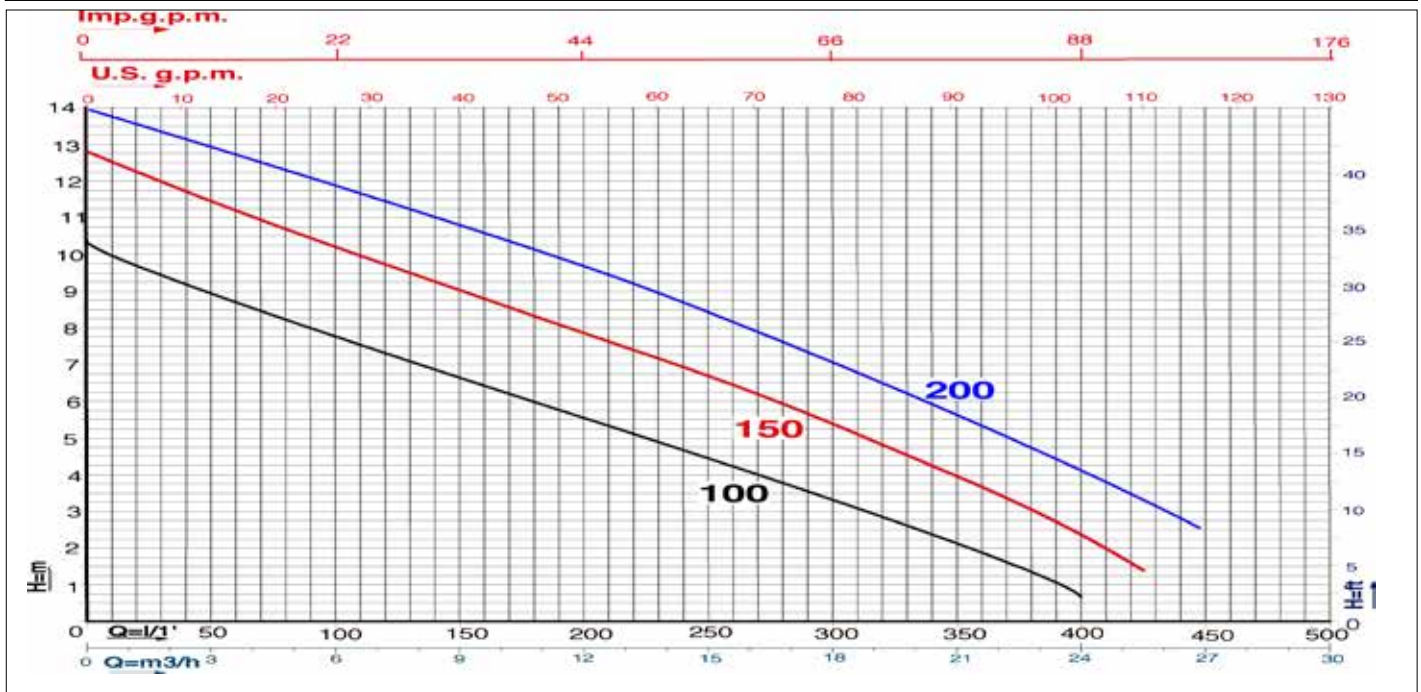
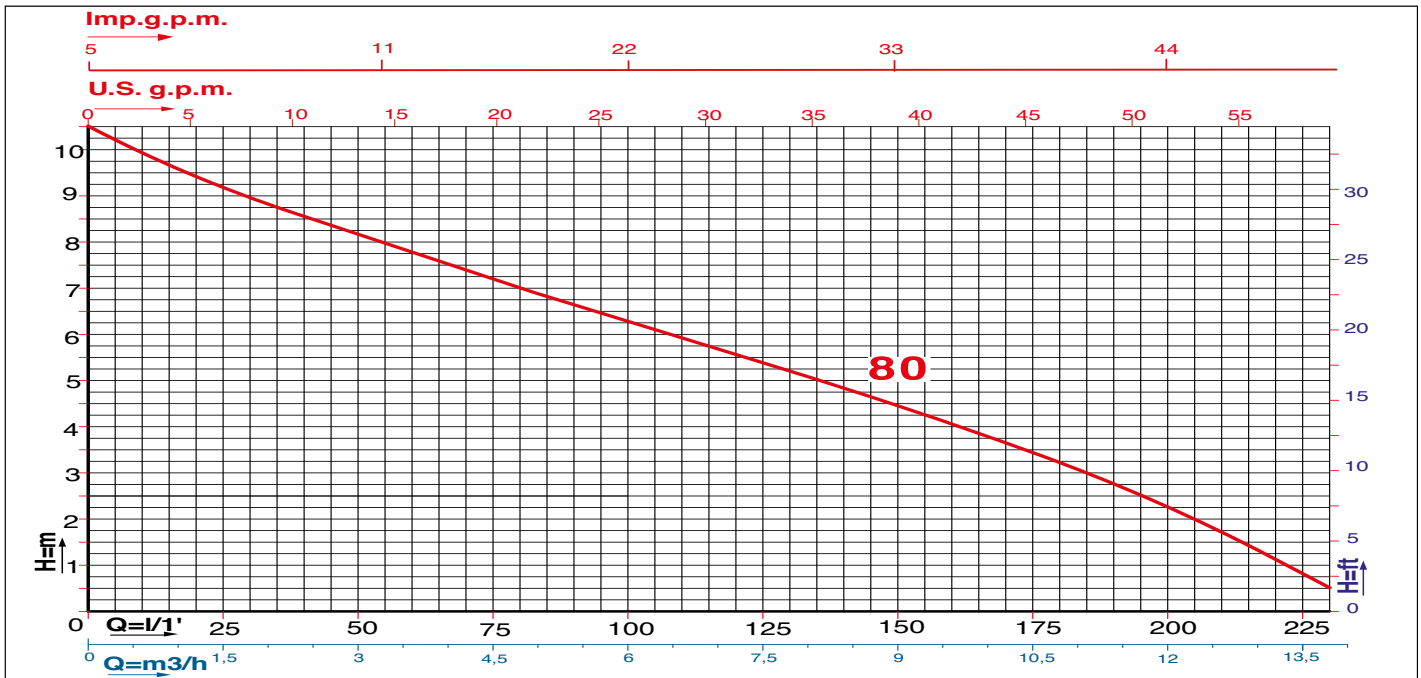

Caratteristiche di funzionamento a 2800 rpm 50Hz e 3450 rpm 60Hz - Performances at 2800 rpm 50 Hz and 3450 rpm 60 Hz
 Le prestazioni valgono per liquidi con densità $\rho = 1,0 \text{ kg/dm}^3$ ed una viscosità $\nu = 1 \text{ mm}^2/\text{s}$ / The performance data holds true for liquids with a $\rho = 1,0 \text{ kg/dm}^3$ density and a $\nu = 1 \text{ mm}^2/\text{s}$ viscosity.

MODELLO MODEL	VOLTAGGIO VOLTAGE 50Hz	DATI ELETTRICI / ELECTRICAL DATA						DATI IDRAULICI / HYDRAULIC DATA										
		P1 max		P2 nom.		I max	Condensatore Capacitor		m³/h		H (m)							
		KW	KW	HP	A	µF	VC	0	3	6	9	12	13,8	18	24	25,5	27	
ARVEX/S 80 M	1 x 220-230V	1,1	0,6	0,8	5,0	16	450	H (m)	0	50	100	150	200	230	300	400	425	450
ARVEX/S 80 T	3x220 or 380V	0,9	0,6	0,8	2,1	---	---		0	50	100	150	200	230	300	400	425	450
ARVEX/S 100 M	1 x 220-230V	1,5	0,75	1,0	6,5	20	450		0	50	100	150	200	230	300	400	425	450
ARVEX/S 100 T	3x220 or 380V	1,3	0,75	1,0	2,6	---	---		0	50	100	150	200	230	300	400	425	450
ARVEX/S 150 M	1 x 220-230V	2,2	1,1	1,5	9,4	30	450		0	50	100	150	200	230	300	400	425	450
ARVEX/S 150 T	3x220 or 380V	1,9	1,1	1,5	3,4	---	---		0	50	100	150	200	230	300	400	425	450
ARVEX/S 200 T	3 x 380-400V	2,5	1,5	2,0	4,3	---	---		0	50	100	150	200	230	300	400	425	450

PREVALENZA TOTALE in METRI COLONNA ACQUA / TOTAL PUMP HEAD AND WATER COLUMN HEIGHT IN m.

CARATTERISTICHE DI COSTRUZIONE:

- ELETTOPOMPA A DOPPIA CAMERA (MOTORE, TENUTA MECCANICA).
 - MOTORE A BAGNO D'OLIO (BIODEGRADABILE E DIELETTRICO) PER RAFFREDDAMENTO E LUBRIFICAZIONE CUSCINETTI.
 - ANELLO DI TENUTA LATO MOTORE.
 - TENUTA MECCANICA A BAGNO D'OLIO.
 - IMMERSIONE MASSIMA: mt. 5.
 - GRADO DI PROTEZIONE IP 68.
 - CLASSE DI ISOLAMENTO: F
 - TEMPERATURA MAX. LIQUIDO POMPATO:
25°C con pompa PARZIALMENTE immersa.
35°C con pompa TOTALMENTE immersa.
 - PASSAGGIO LIBERO: 50 mm.
 - VERSIONI:
Monofase: 220-277V/50Hz o 220-277V/60 Hz con protettore termico incorporato e condensatore permanentemente inserito.
Trifase: 220-277V/50Hz o 380-480V/50Hz e 220-277V/60Hz o 380-480V/60Hz con protezione da sovraccarico a cura dell'utente.
 - VERSIONI MONOFASI AUTOMATICHE CON GALLEGGIANTE O MANUALI SENZA GALLEGGIANTE.
 - CAVO STANDARD:
Monofase: 10 metri H05VV-F per versione normale (aut.-man.).
Trifase: 10 metri H05VV-F
- SPECIALI VOLTAGGI E FREQUENZE A RICHIESTA.

DESIGN ENGINEERING:

- DOUBLE CHAMBER ELECTRIC PUMP (MOTOR, MECHANICAL SEAL).
 - OIL BATH MOTOR (BIODEGRADABLE AND DIELECTRIC) FOR COOLING AND BEARING LUBRICATION.
 - SEALING RING - ENGINE FACE.
 - OIL BATH MECHANICAL SEALS.
 - PERMISSIBLE DRAUGHT OF WATER: 5 m.
 - IP 68 PROTECTION CLASS.
 - CLASS "F" INSULATION.
 - MAX. PUMPED LIQUID TEMPERATURE:
25°C with PARTIALLY submerged pump.
35°C with TOTALLY submerged pump.
 - BY PASS SECTION: 50 mm.
 - VERSIONS:
Single Phase: 220-277V/50Hz or 220-277V/60 Hz with built in thermal protection and permanent capacitor.
Three Phase: 220-277V/50Hz or 380-480V/50Hz and 220-277V/60Hz or 380-480V/60Hz with overload protection care of the User.
 - AUTOMATIC SINGLE PHASE VERSIONS WITH FLOATER OR MANUAL WITHOUT FLOATER.
 - STANDARD CABLE FEATURES:
Single Phase: 10 metres H05VV-F for the standard version (automatic-manual).
Three Phase: 10 metres H05VV-F
- CUSTOMISED VOLTAGE AND FREQUENCY RATING AVAILABLE ON DEMAND.

TABELLA MATERIALI / MATERIALS TABLE:

Pos.	Componente / Component		Materiale / Materials
A	Carcassa esterna / External housing		ACCIAIO INOX AISI 316 DIN 1.4401 STAINLESS STEEL
B	Girante / Impeller		
C	Albero (lato pompa) / Shaft (pump side)		
D	Tenuta meccanica Mechanical seal	Lato pompa / Pump face	CARBURO DI SILICIO-VITON SILICON CARBIDE-VITON
		Lato motore / Motor face	ANELLO DI TENUTA NBR NBR SEAL RING
E	O-ring		VITON
G	Porta motore / Motor holder		ACCIAIO INOX AISI 316 DIN 1.4401 STAINLESS STEEL
I	Coperchio + maniglia / Cover + handle		
N	Base d'appoggio / Base holder		
P	Corpo pompa / Pump body		

ARVEX BC 100/S - 150/S - 200/S

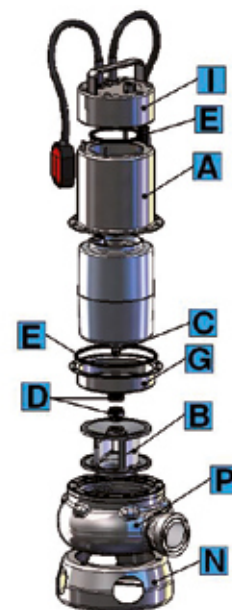

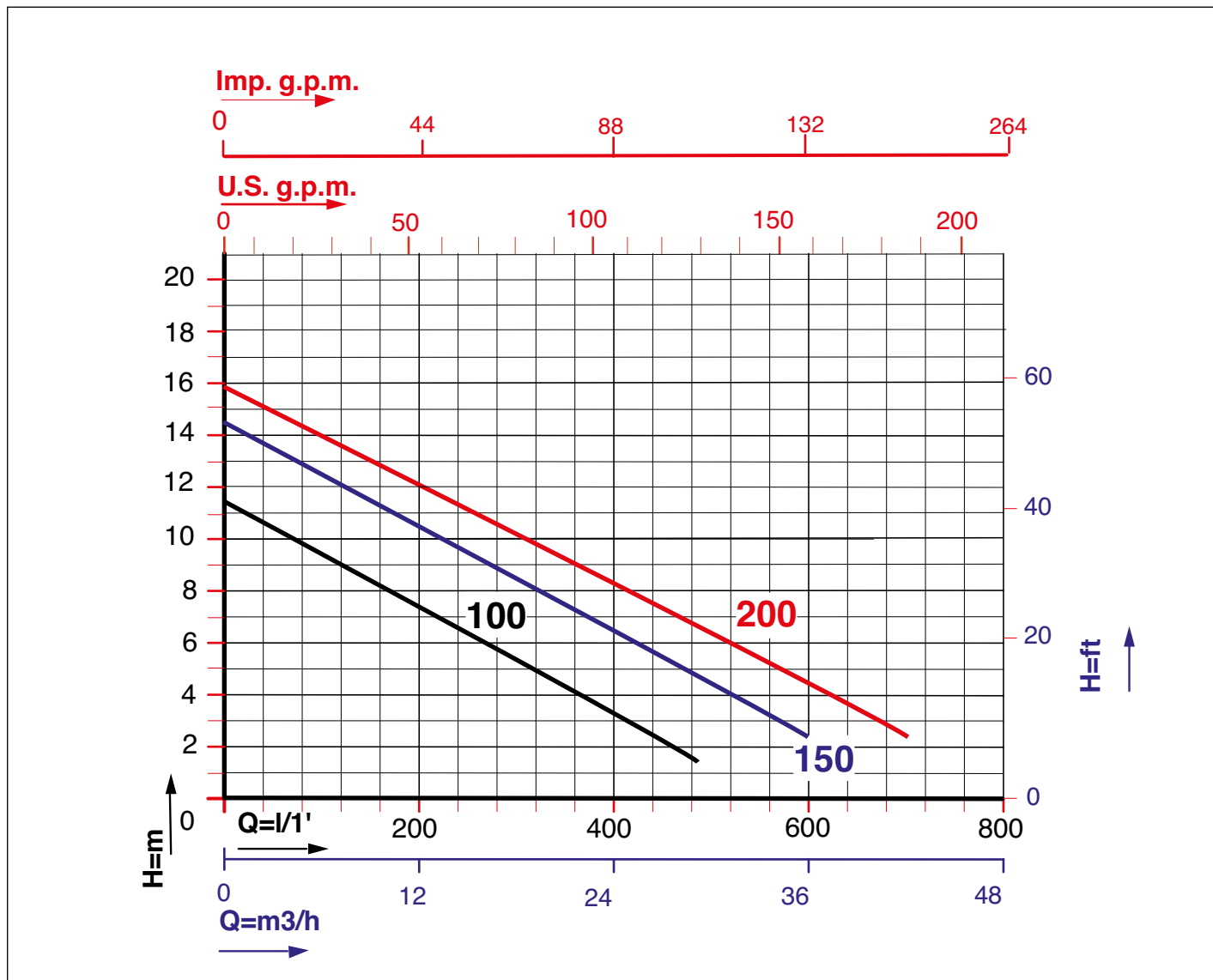

Caratteristiche di funzionamento a 2800 rpm 50Hz e 3450 rpm 60Hz - Performances at 2800 rpm 50 Hz and 3450 rpm 60 Hz
 Le prestazioni valgono per liquidi con densità $\rho = 1,0 \text{ kg/dm}^3$ ed una viscosità $\nu = 1 \text{ mm}^2/\text{s}$ / The performance data holds true for liquids with a $\rho = 1,0 \text{ kg/dm}^3$ density and a $\nu = 1 \text{ mm}^2/\text{s}$ viscosity.

MODELLO MODEL	VOLTAGGIO VOLTAGE	DATI ELETTRICI / ELECTRICAL DATA						DATI IDRAULICI / HYDRAULIC DATA										
		P1max	P2 nom.		I max	Condensatore Capacitor		m³/h	0	3	6	12	18	24	30	36	42	
50Hz		kW	kW	HP	Ampere	µF	VC	l/min.	0	50	100	200	300	400	500	600	700	
ARVEX/S BC 100 M	1 x 220-230V	1,5	0,75	1,0	7,0	20	450	H (m)	11,5	10,5	9,5	7,5	5,5	3,5	1,5			
ARVEX/S BC 100 T	3x380V - 400V	1,3	0,75	1,0	3,2	---	---		11,5	10,5	9,5	7,5	5,5	3,5	1,5			
ARVEX/S BC 150 M	1 x 220-230V	2,2	1,1	1,5	11,5	30	450		14,5	13,5	12,5	10,5	8,5	6,5	4,5	2,5		
ARVEX/S BC 150 T	3x380V - 400V	1,7	1,1	1,5	4,5	---	---		14,5	13,5	12,5	10,5	8,5	6,5	4,5	2,5		
ARVEX/S BC 200 T	3x380V - 400V	2,2	1,5	2,0	4,8	---	---		16,0	14,8	14,0	12,0	10,5	8,2	6,5	4,3	2,5	

PREVALENZA TOTALE in METRI COLONNA ACQUA / TOTAL PUMP HEAD AND WATER COLUMN HEIGHT IN m.

DIMENSIONI E PESI / SIZE AND WEIGHT DATA:

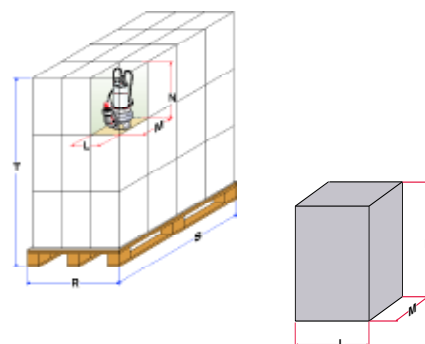
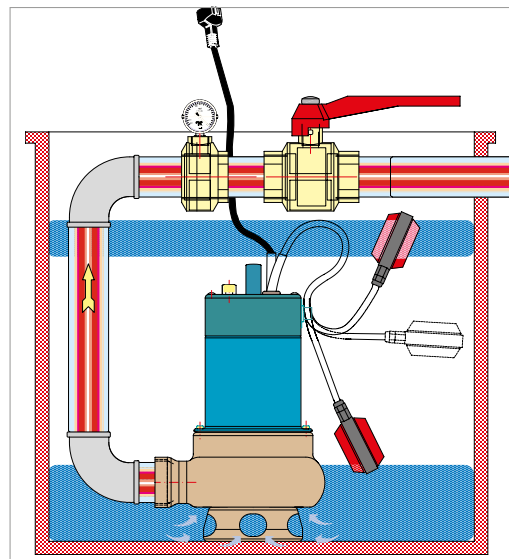
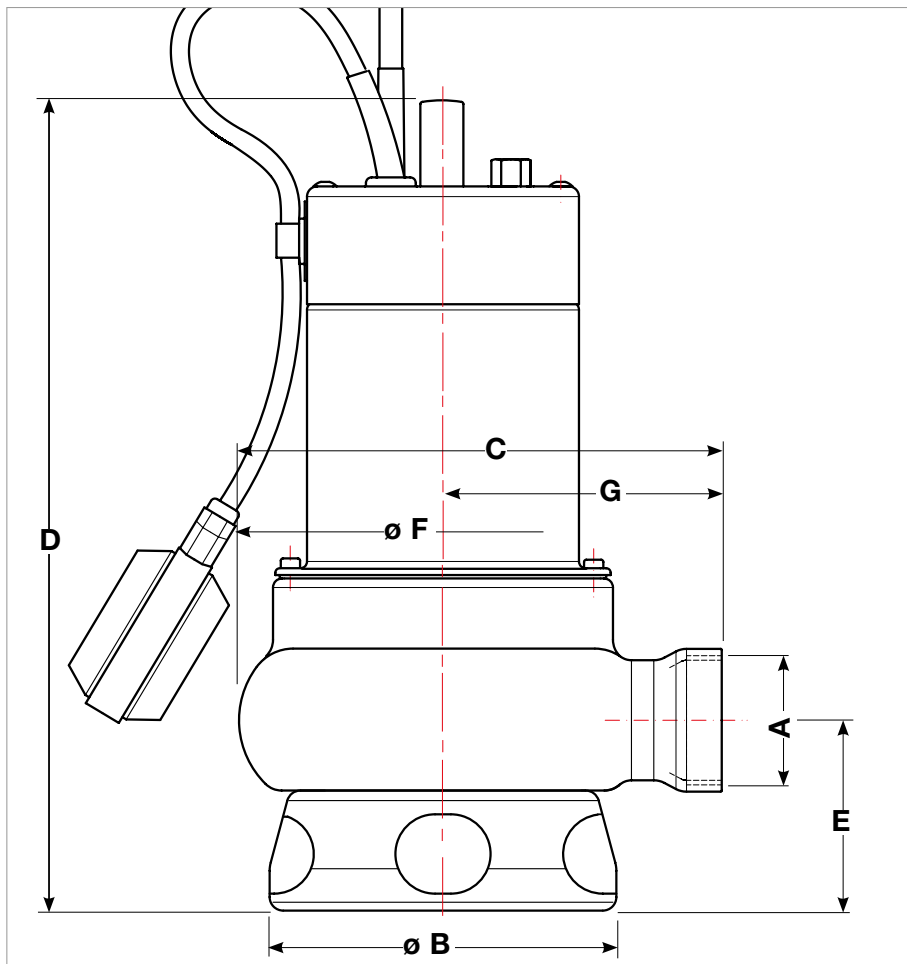

MODELLO MODEL	DIMENSIONI POMPA in mm. / PUMP DIMENSIONS in mm.						
	A	B	C	D	E	F	G
ARVEX/S 80 M	2"	176	214	358	88	180	124
ARVEX/S 80 T	2"	176	214	358	88	180	124
ARVEX/S 100 M	2"	176	214	358	88	180	124
ARVEX/S 100 T	2"	176	214	358	88	180	124
ARVEX/S 150 M	2"	176	214	398	88	180	124
ARVEX/S 150 T	2"	176	214	398	88	180	124
ARVEX/S BC 100	2"	176	214	369	88	180	124
ARVEX/S BC 150	2"	176	214	409	88	180	124
ARVEX/S BC 200	2"	176	214	409	88	180	124

MODELLO MODEL	DIMENSIONI SCATOLA / PACKING DIMENSIONS				DIMENSIONI PALLET / PALLET DIMENSIONS				
	L mm.	M mm.	N mm.	Peso / Weight Kg.	R mm.	S mm.	T mm.	nr. scatole/cartons	Peso / Weight Kg.
ARVEX/S 80 M	190	230	410	10,5	800	1200	1360	60	650
ARVEX/S 80 T	190	230	410	10,5	800	1200	1360	60	650
ARVEX/S 100 M	190	230	410	11,5	800	1200	1360	60	715
ARVEX/S 100 T	190	230	410	11,5	800	1200	1360	60	715
ARVEX/S 150 M	190	230	410	13,5	800	1200	1360	60	835
ARVEX/S 150 T	190	230	410	13,5	800	1200	1360	60	835
ARVEX/S BC 100	190	230	480	12,5	800	1200	1570	60	775
ARVEX/S BC 150	190	230	480	14,5	800	1200	1570	60	895
ARVEX/S BC 200	190	230	480	14,5	800	1200	1570	60	895

ARVEX aisi 304



ELETTROPOMPE SOMMERGIBILI VORTEX E BICANALI PER ACQUE CARICHE SUBMERSIBLE VORTEX AND BICANAL ELECTRIC PUMPS FOR WASTEWATER

PREVALENZA : 9,5 m ÷ 16,0 m
PORTATA : 18,0 m³/h ÷ 42 m³/h
POTENZA NOMINALE : 0,75 kW (1,0HP) ÷ 1,5 kW (2,0HP)
PASSAGGIO SOLIDI FINO A 50 mm.

APPLICAZIONI

- SVUOTAMENTO DI FOSSE DI DECANTAZIONE, POZZI NERI, POZZI DI RACCOLTA LIQUAMI.
- POMPAGGIO DI ACQUE LURIDE ANCHE CON CORPI SOLIDI IN SOSPENSIONE.
- MOVIMENTAZIONE DI ACQUE LURIDE AD USO DOMESTICO ED INDUSTRIALE.

PUMP HEAD : 9,5 mt ÷ 16,0 mt
DELIVERY : 18,0 m³/h ÷ 42,0 m³/h
RATED HORSEPOWER : 0,75 kW (1,0HP) ÷ 1,5 kW (2,0HP)
SOLID MATTER BYPASS up to 50 mm.

APPLICATIONS

- DECANTATION PIT, SEWAGE PIT AND SLURRY COLLECTION PIT PUMP OUT.
- PUMP OUT OF LAVATORY/FOUL WATER WITH POSSIBLE FLOATING SOLIDS CONTENTS.
- DOMESTIC AND INDUSTRIAL LAVATORY/BLACK WATER HANDLING SYSTEMS.



CARATTERISTICHE DI COSTRUZIONE:

- ELETTOPOMPA A DOPPIA CAMERA (MOTORE, TENUTA MECCANICA).
- MOTORE A BAGNO D'OLIO (BIODEGRADABILE E DIELETTRICO) PER RAFFREDDAMENTO E LUBRIFICAZIONE CUSCINETTI.
- ANELLO DI TENUTA LATO MOTORE.
- TENUTA MECCANICA A BAGNO D'OLIO.
- IMMERSIONE MASSIMA: mt. 5 .
- GRADO DI PROTEZIONE IP 68 .
- CLASSE DI ISOLAMENTO: F
- TEMPERATURA MAX. LIQUIDO POMPATO:
25°C con pompa PARZIALMENTE immersa.
35°C con pompa TOTALMENTE immersa.
- PASSAGGIO LIBERO: 40mm ARVEX 80
50mm ARVEX 100-150-200
- VERSIONI:
Monofase: 220-277V/50Hz o 220-277V/60Hz con protettore termico incorporato e condensatore permanentemente inserito.
Trifase: 220-277V/50Hz o 380-480V/50Hz e 220-277V/60Hz o 380-480V/60Hz con protezione da sovraccarico a cura dell'utente.

- VERSIONI MONOFASI AUTOMATICHE CON GALLEGGIANTE O MANUALI SENZA GALLEGGIANTE.
- CAVO STANDARD:
Monofase: 5 e 10 metri H07RN-F (aut.-man.).
Trifase: 10 metri H07RN-F

SPECIALI VOLTAGGI E FREQUENZE A RICHIESTA.

OPTIONAL:

- SISTEMI DI DISCESA (DN50) PER IMPIANTI FISSI (VEDERE PAGINA 108-109)

DESIGN ENGINEERING:

- DOUBLE CHAMBER ELECTRIC PUMP (MOTOR, MECHANICAL SEAL).
- OIL BATH MOTOR (BIODEGRADABLE AND DIELECTRIC) FOR COOLING AND BEARING LUBRICATION.
- SEALING RING - ENGINE FACE.
- OIL BATH MECHANICAL SEALS.
- PERMISSIBLE DRAUGHT OF WATER: 5 m
- IP 68 PROTECTION CLASS.
- CLASS "F" INSULATION.
- MAX. PUMPED LIQUID TEMPERATURE:
25°C with PARTIALLY submerged pump.
35°C with TOTALLY submerged pump.
- BY PASS SECTION: 40mm ARVEX 80
50mm ARVEX 100-150-200
- VERSIONS:
Single Phase: 220-277V/50Hz or 220-277V/60Hz with built in thermal protection and permanent capacitor.
Three Phase: 220-277V/50Hz or 380-480V/50Hz and 220-277V/60Hz or 380-480V/60Hz with overload protection care of the User.

- AUTOMATIC SINGLE PHASE VERSIONS WITH FLOATER OR MANUAL WITHOUT FLOATER.
- STANDARD CABLE FEATURES:
Single Phase: 5 and 10 metres H07RN-F for the standard version (automatic manual).
Three Phase: 10 metres H07RN-F

CUSTOMISED VOLTAGE AND FREQUENCY RATING AVAILABLE ON DEMAND.

OPTIONAL:

- DOWN STROKE GUIDE RAIL SYSTEMS (DN50) FOR FIXED PLANTS (SEE PAGE 108-109)

TABELLA MATERIALI / MATERIALS TABLE:

Pos.	Componente / Component		Materiale / Materials
A	Carcassa esterna / External housing		ACCIAIO INOX AISI 304 DIN 1.4301 STAINLESS STEEL
B	Girante / Impeller		
C	Albero (lato pompa) / Shaft (pump side)		ACCIAIO INOX AISI 316 DIN 1.4401 STAINLESS STEEL
D	Tenuta meccanica Mechanical seal	Lato pompa/ Pump side	GRAFITE-CERAMICA GRAPHITE-CERAMIC
		Lato motore/ motor side	ANELLO DI TENUTA NBR NBR SEAL RING
E	O-ring		NBR
G	Porta motore / Motor holder		ACCIAIO INOX AISI 304 DIN 1.4301 STAINLESS STEEL
I	Coperchio + maniglia / Cover + handle		
N	Base d'appoggio / Base holder		
P	Corpo pompa / Pump body		

ARVEX 80- 100 - 150 - 200

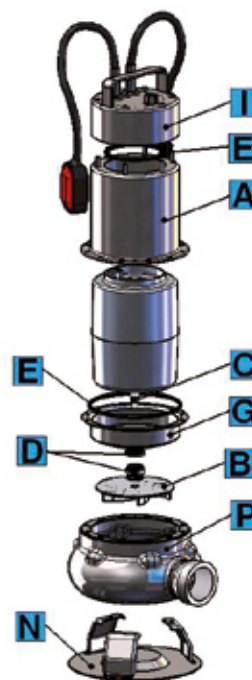

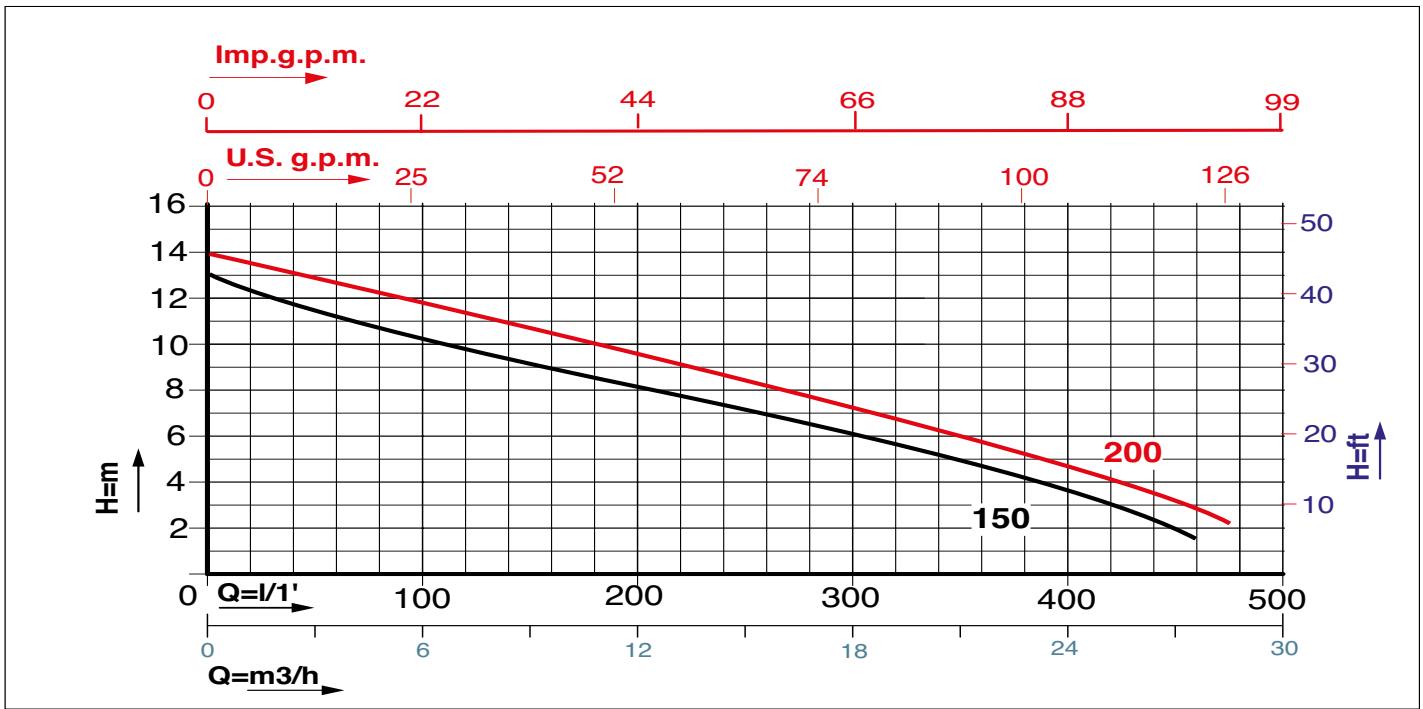
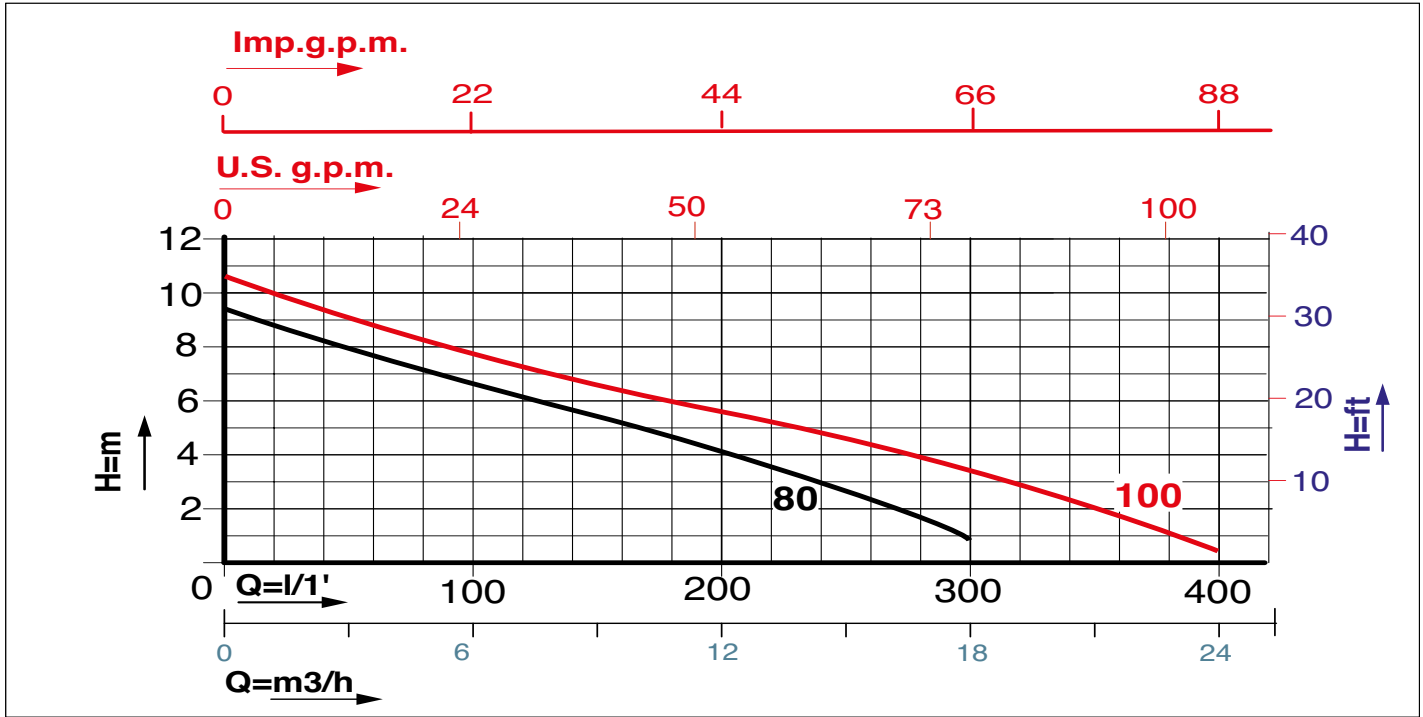

Caratteristiche di funzionamento a 2800 rpm 50Hz e 3450 rpm 60Hz - Performances at 2800 rpm 50 Hz and 3450 rpm 60 Hz
 Le prestazioni valgono per liquidi con densità $\rho = 1,0 \text{ kg/dm}^3$ ed una viscosità $\nu = 1 \text{ mm}^2/\text{s}$ / The performance data holds true for liquids with a $\rho = 1,0 \text{ kg/dm}^3$ density and a $\nu = 1 \text{ mm}^2/\text{s}$ viscosity.

MODELLO MODEL	VOLTAGGIO VOLTAGE	DATI ELETTRICI / ELECTRICAL DATA						DATI IDRAULICI / HYDRAULIC DATA												
		P1max	P2 nom.		I max	Condensatore Capacitore		m³/h		H (m)										
50Hz		kW	kW	HP	Ampere	µF	VC	0	3	6	9	12	15,6	18	24	25,5	27,0	l/min.		
								0	50	100	150	200	260	300	400	425	450			
ARVEX 80 M	1 x 220-240V	1,1	0,6	0,8	5,1	16	450	9,5	8,0	6,7	5,5	4,2	2,4	0,6						
ARVEX 80 T	3x 380V - 400V	0,9	0,6	0,8	2,1	---	---	9,5	8,0	6,7	5,5	4,2	2,4	0,6						
ARVEX 100 M	1 x 220-240V	1,5	0,75	1,0	6,5	20	450	10,5	8,6	7,6	6,6	5,4	4,4	3,2	0,6					
ARVEX 100 T	3x 380V - 400V	1,3	0,75	1,0	2,6	---	---	10,5	8,6	7,6	6,6	5,4	4,4	3,2	0,6					
ARVEX 150 M	1 x 220-240V	2,2	1,1	1,5	10,4	30	---	13,0	11,4	10,4	9,4	8,4	7,0	5,4	2,5	1,6				
ARVEX 150 T	3x 380V - 400V	1,7	1,1	1,5	3,3	---	---	13,0	11,4	10,4	9,4	8,4	7,0	5,4	2,5	1,6				
ARVEX 200 M	1 x 220V - 240V	2,4	1,5	2,0	11,5	30	450	14,0	13,0	12,0	10,8	9,8	8,4	7,4	4,0	3,4	2,4			
ARVEX 200 T	3x 380V - 400V	2,2	1,5	2,0	3,7	---	---	14,0	13,0	12,0	10,8	9,8	8,4	7,4	4,0	3,4	2,4			

CARATTERISTICHE DI COSTRUZIONE:

- ELETTOPOMPA A DOPPIA CAMERA (MOTORE, TENUTA MECCANICA).
- MOTORE A BAGNO D'OLIO (BIODEGRADABILE E DIELETTRICO) PER RAFFREDDAMENTO E LUBRIFICAZIONE CUSCINETTI.
- ANELLO DI TENUTA LATO MOTORE.
- TENUTA MECCANICA A BAGNO D'OLIO.
- IMMERSIONE MASSIMA: mt. 5 .
- GRADO DI PROTEZIONE IP 68 .
- CLASSE DI ISOLAMENTO: F
- TEMPERATURA MAX. LIQUIDO POMPATO:
25°C con pompa PARZIALMENTE immersa.
35°C con pompa TOTALMENTE immersa.
- PASSAGGIO LIBERO: 50 mm

- VERSIONI:
Monofase: 220-277V / 50Hz o 220 - 277V/ 60Hz con protettore termico incorporato e condensatore permanentemente inserito.
Trifase: 220 - 277V/ 50Hz o 380-480V/50 Hz e 220 - 277V/ 60Hz o 380 - 480V/ 60Hz con protezione da sovraccarico a cura dell'utente.

- VERSIONI MONOFASI AUTOMATICHE CON GALLEGGIANTE O MANUALI SENZA GALLEGGIANTE.
- CAVO STANDARD:
Monofase: 10 metri H07RN-F (automatico - manuale).
Trifase: 10 metri H07RN-F

SPECIALI VOLTAGGI E FREQUENZE A RICHIESTA

OPTIONAL:

- SISTEMI DI DISCESA DN50 PER IMPIANTI FISSI (VEDERE PAGINA 108)

DESIGN ENGINEERING:

- DOUBLE CHAMBER ELECTRIC PUMP (MOTOR, MECHANICAL SEAL).
- OIL BATH MOTOR (BIODEGRADABLE AND DIELECTRIC) FOR COOLING AND BEARING LUBRICATION.
- SEALING RING - ENGINE FACE
- OIL BATH MECHANICAL SEALS.
- PERMISSIBLE DRAUGHT OF WATER: 5 m
- IP 68 PROTECTION CLASS.
- CLASS "F" INSULATION.
- MAX. PUMPED LIQUID TEMPERATURE:
25°C with PARTIALLY submerged pump.
35°C with TOTALLY submerged pump.
- BY PASS SECTION: 50 mm

- VERSIONS:
Single Phase: 220 – 277V / 50Hz or 220 – 277V / 60 Hz with built in thermal protection and permanent capacitor.
Three Phase: 220-277V/50 Hz or 380 – 480V / 50Hz and 220- 277V or 380 - 480V / 60Hz with overload protection care of the User.

- AUTOMATIC SINGLE PHASE VERSIONS WITH FLOATER OR MANUAL WITHOUT FLOATER.
- STANDARD CABLE FEATURES:
Single Phase: 10 metres H07RN-F (automatic-manual).
Three Phase: 10 metres H07RN-F

CUSTOMISED VOLTAGE AND FREQUENCY RATING AVAILABLE ON DEMAND.

OPTIONAL:

- DOWN STROKE GUIDE RAIL SYSTEMS DN50 FOR FIXED PLANTS (SEE PAGE 108)

TABELLA MATERIALI / MATERIALS TABLE:

Pos.	Componente / Component		Materiale / Materials
A	Carcassa esterna / External housing		ACCIAIO INOX AISI 304 DIN 1.4301 STAINLESS STEEL
B	Girante / Impeller		ACCIAIO INOX AISI 316 DIN 1.4401 STAINLESS STEEL
C	Albero (lato pompa) / Shaft (pump side)		
D	Tenuta meccanica Mechanical seal	Lato pompa/ Pump side	GRAFITE - CERAMICA GRAPHITE - CERAMIC
		Lato motore/ motor side	ANELLO DI TENUTA NBR NBR SEAL RING
E	O-ring		NBR
G	Porta motore / Motor holder		ACCIAIO INOX AISI 304 DIN 1.4301 STAINLESS STEEL
I	Coperchio + maniglia / Cover + handle		
N	Base d'appoggio / Base holder		
P	Corpo pompa / Pump body		

ARVEX - BC 100 - 150 - 200

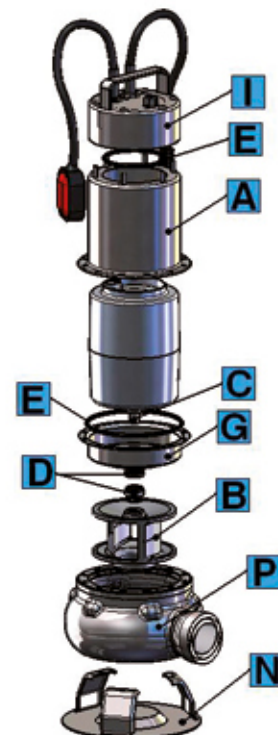

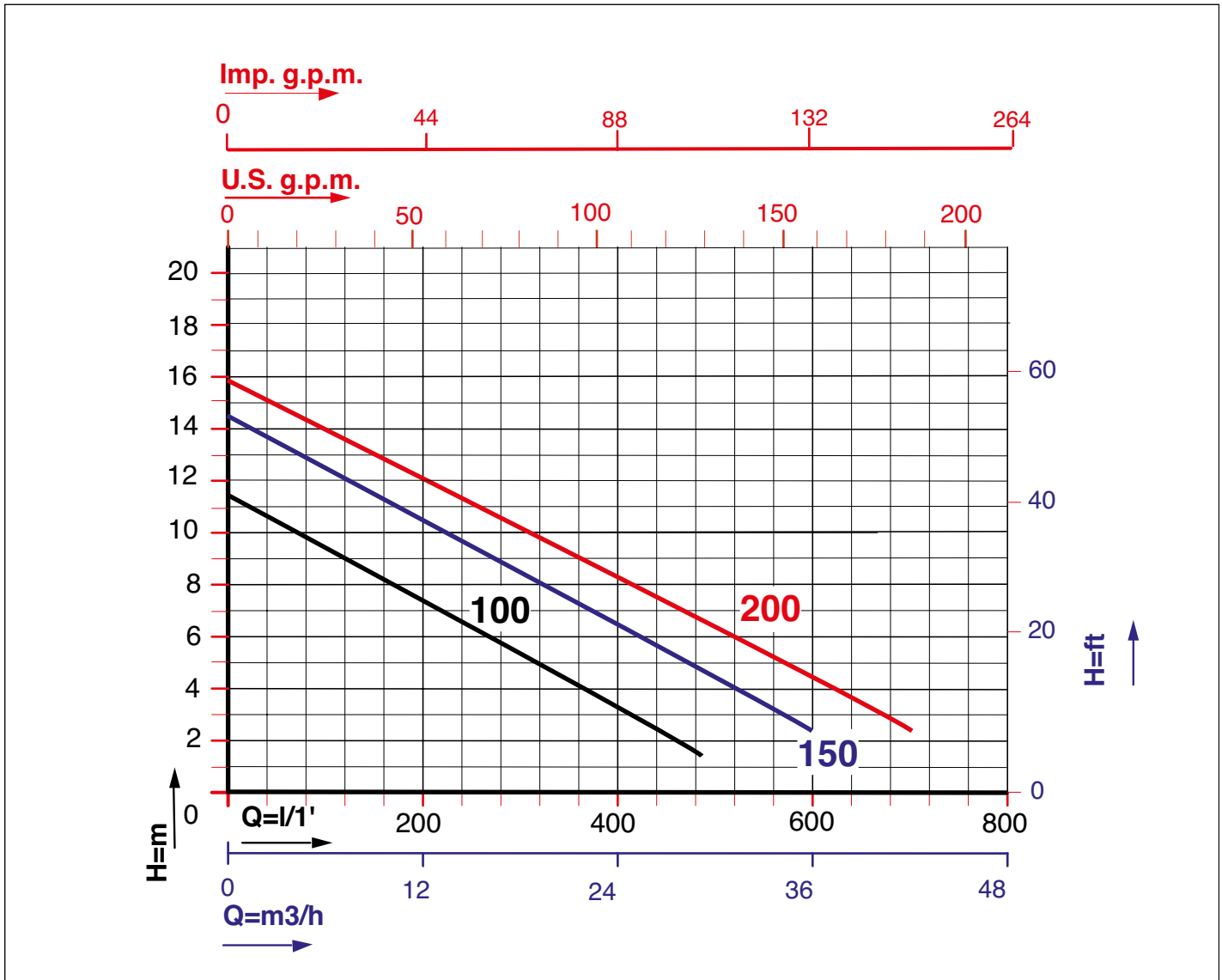

Caratteristiche di funzionamento a 2800 rpm 50Hz e 3450 rpm 60Hz - Performances at 2800 rpm 50 Hz and 3450 rpm 60 Hz
 Le prestazioni valgono per liquidi con densità $\rho = 1,0 \text{ kg/dm}^3$ ed una viscosità $\nu = 1 \text{ mm}^2/\text{s}$ / The performance data holds true for liquids with a $\rho = 1,0 \text{ kg/dm}^3$ density and a $\nu = 1 \text{ mm}^2/\text{s}$ viscosity.

MODELLO MODEL	VOLTAGGIO VOLTAGE	DATI ELETTRICI / ELECTRICAL DATA						DATI IDRAULICI / HYDRAULIC DATA									
		P1max	P2 nom.		I max	Condensatore Capacitor		m³/h	0	3	6	12	18	24	30	36	42
	50Hz	kW	kW	HP	Ampere	µF	VC	l/min.	0	50	100	200	300	400	500	600	700
ARVEX BC 100 M	1 x 220-230V	1,5	0,75	1,0	7,0	20	450	H (m)	11,5	10,5	9,5	7,5	5,5	3,5	1,5		
ARVEX BC 100 T	3x 380V - 400V	1,3	0,75	1,0	3,2	---	---		11,5	10,5	9,5	7,5	5,5	3,5	1,5		
ARVEX BC 150 M	1 x 220-230V	2,2	1,1	1,5	11,5	30	450		14,5	13,5	12,5	10,5	8,5	6,5	4,5	2,5	
ARVEX BC 150 T	3x 380V - 400V	1,7	1,1	1,5	4,5	---	---		14,5	13,5	12,5	10,5	8,5	6,5	4,5	2,5	
ARVEX BC 200 T	3x 380V - 400V	2,2	1,5	2,0	4,8	---	---		16,0	14,8	14,0	12,0	10,5	8,2	6,5	4,3	2,5

PREVALENZA TOTALE IN METRI COLONNIA ACQUA / TOTAL PUMP HEAD AND WATER COLUMN HEIGHT IN m.

DIMENSIONI e PESI / SIZE AND WEIGHT DATA:

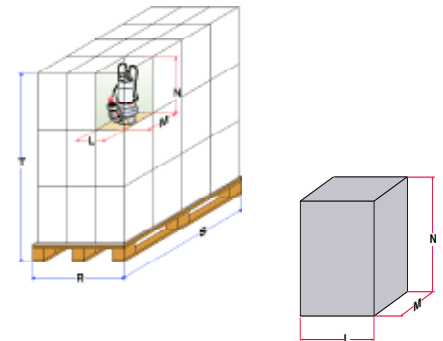
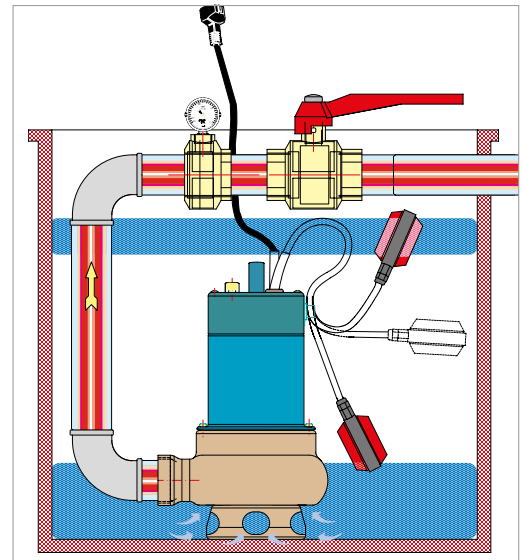
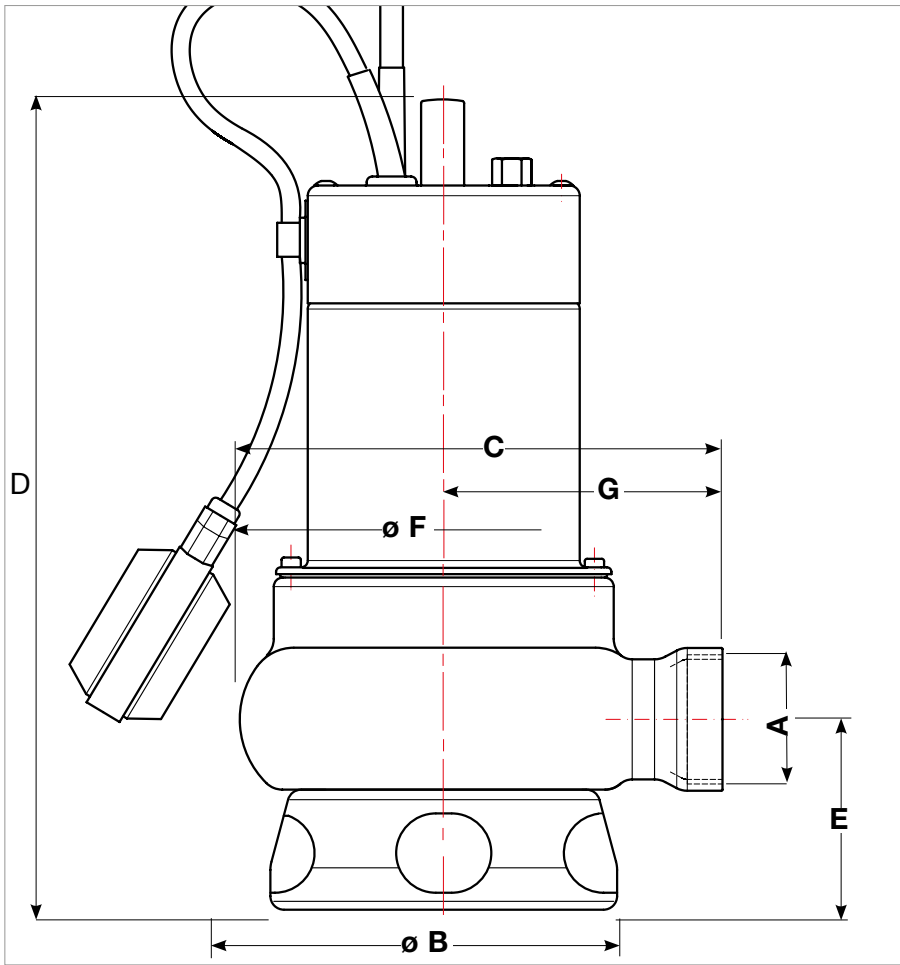

MODELLO MODEL	DIMENSIONI POMPA in mm. / PUMP DIMENSIONS in mm.						
	A	B	C	D	E	F	G
ARVEX 80	1" 1/2	180	214	358	88	180	124
ARVEX 100	2"	180	214	358	88	180	124
ARVEX 150	2"	180	214	398	88	180	124
ARVEX 200	2"	180	214	398	88	180	124
ARVEX BC 100	2"	180	214	369	88	180	124
ARVEX BC 150	2"	180	214	409	88	180	124
ARVEX BC 200	2"	180	214	409	88	180	124

MODELLO MODEL	DIMENSIONI SCATOLA / PACKING DIMENSIONS				DIMENSIONI PALLET / PALLET DIMENSIONS				
	L mm.	M mm.	N mm.	Peso / Weight Kg.	R mm.	S mm.	T mm.	nr. scatole/cartons	Peso / Weight Kg.
ARVEX 80	190	230	410	10,5	800	1200	1360	60	650
ARVEX 100	190	230	410	11,5	800	1200	1360	60	715
ARVEX 150	190	230	480	13,5	800	1200	1570	60	835
ARVEX 200	190	230	480	13,5	800	1200	1570	60	835
ARVEX BC 100	190	230	480	12,5	800	1200	1570	60	775
ARVEX BC 150	190	230	480	14,5	800	1200	1570	60	895
ARVEX BC 200	190	230	480	14,5	800	1200	1570	60	895

RIVER



ELETTROPOMPE SOMMERSIBILI MONOCANALI PER ACQUE CARICHE DOTATE DI CONTROFLANGIA SUBMERSIBLE SINGLE CHANNEL ELECTRIC PUMP FOR VERY FOUL WASTE WATER, FEATURING A COUNTER FLANGE

PREVALENZA : 10,5 mt. ÷ 30,5 mt.
PORTATA : 30 m³/h ÷ 96 m³/h
POTENZA NOMINALE : 1,1 kW (1,5HP) ÷ 4,5 kW (6,0HP)
PASSAGGIO SOLIDI FINO A 60 mm.

PUMP HEAD : 10,5 mt ÷ 30,5 mt
DELIVERY : 30,0 m³/h ÷ 96,0 m³/h
RATED HORSEPOWER : 1,1 kW (1,5HP) ÷ 4,5 kW (6,0HP)
SOLID MATTER BYPASS up to 60 mm

APPLICAZIONI

- SVUOTAMENTO DI FOSSE DI DECANTAZIONE, POZZI DI RACCOLTA LIQUAMI.
- POMPAGGIO DI ACQUE LURIDE ANCHE CON CORPI SOLIDI E PARTI FIBROSE IN SOSPENSIONE.
- MOVIMENTAZIONE DI ACQUE LURIDE AD USO DOMESTICO E INDUSTRIALE

APPLICATIONS

- DECANTATION PIT, SLURRY COLLECTION PIT PUMP OUT.
- LAVATORY/FOUL WATER WITH FLOATING/NON-FLOATING SOLIDS AND FIBRE SUSPENSIDS PUMP OUT.
- DOMESTIC AND INDUSTRIAL LAVATORY/BLACK WATER HANDLING SYSTEMS.

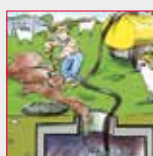

CARATTERISTICHE DI COSTRUZIONE:

- ELETTOPOMPA A DOPPIA CAMERA (MOTORE TENUTA MECCANICA).
- ELETTOPOMPA A UNICA CAMERA (SOLO PER RIVER 300F - 600F)
- MOTORE A BAGNO D'OLIO (BIODEGRADABILE E DIELETTRICO) PER RAFFREDDAMENTO E LUBRIFICAZIONE CUSCINETTI.
- ANELLO DI TENUTA LATO MOTORE.
- TENUTA MECCANICA A BAGNO D'OLIO.
- DOPPIA TENUTA MECCANICA (SOLO RIVER 300F - 600F):
LATO MOTORE A BAGNO D'OLIO
LATO POMPA IN BAGNO D'ACQUA
- IMMERSIONE MASSIMA: mt. 5.
- GRADO DI PROTEZIONE IP 68.
- CLASSE DI ISOLAMENTO: F
- TEMPERATURA MAX.LIQUIDO POMPATO:
25°C con pompa PARZIALMENTE immersa.
35°C con pompa TOTALMENTE immersa.
- PASSAGGIO LIBERO: 50 mm - RIVER 150F **a** (monocanale aperta)
60 mm - RIVER 200F **a** (monocanale aperta)
50 mm - RIVER 300F **c** (monocanale chiusa)
50 mm - RIVER 400F **c** (monocanale chiusa)
50 mm - RIVER 600F **c** (monocanale chiusa)
- VERSIONI: Monofase: 220-277V/50Hz o 220-277V/60Hz con protettore termico incorporato e condensatore permanentemente inserito.
Trifase: 220-277V/50Hz o 220-277V/60Hz e 380-480V/50Hz con protezione da sovraccarico a cura dell'utente.
- POTENZA MOTORE: DA 1,5 Hp a 2 Hp VERSIONI MONOFASE E TRIFASE.
DA 3 Hp a 6 Hp solo VERSIONI TRIFASE.
- VERSIONI MONOFASI AUTOMATICHE CON GALLEGGIANTE fino a 1,5 HP.

VERSIONI MONOFASI da 2 Hp solo MANUALI SENZA GALLEGGIANTE.

- CAVO STANDARD: Monofase: 10 metri H07RN-F per versione normale (aut.-man).
Trifase: 10 metri H07RN-F

SPECIALI VOLTAGGI E FREQUENZE A RICHIESTA.

OPTIONAL:

- SISTEMI DI DISCESA DN80 PER IMPIANTI FISSI (VEDERE PAGINA 108-109)

DESIGN ENGINEERING:

- DOUBLE CHAMBER ELECTRIC PUMP (MOTOR, MECHANICAL SEAL).
 - SINGLE CHAMBER ELECTRIC PUMP (ONLY FOR RIVER 300F - 600F)
 - OIL BATH MOTOR (BIODEGRADABLE AND DIELECTRIC) FOR COOLING AND BEARING LUBRICATION.
 - SEALING RING - ENGINE FACE.
 - OIL BATH MECHANICAL SEALS.
 - DOUBLE MECHANICAL SEALS (ONLY FOR RIVER 300F - 600F):
ENGINE FACE: OIL BATH
PUMP FACE: WATER BATH.
 - PERMISSIBLE DRAUGHT OF WATER: 5 m
 - IP 68 PROTECTION CLASS.
 - CLASS "F" INSULATION.
 - MAX. PUMPED LIQUID TEMPERATURE:
25°C with PARTIALLY submerged pump.
35°C with TOTALLY submerged pump.
 - BY PASS SECTION: 50 mm - RIVER 150F **a** (open single channel)
60 mm - RIVER 200F **a** (open single channel)
50 mm - RIVER 300F **c** (close single channel)
50 mm - RIVER 400F **c** (close single channel)
50 mm - RIVER 600F **c** (close single channel)
 - VERSIONS: Single Phase: 220-277V/50Hz with built in thermal protection and permanent capacitor.
Three Phase: 220-277V/50Hz or 220-277V/60Hz and 380-480V/50Hz with overload protection care of the User.
 - MOTOR POWER: From 1,5HP to 2HP SINGLE PHASE & THREE PHASE VERSIONS
From 3HP to 6HP Only THREE PHASE VERSIONS.
 - AUTOMATIC SINGLE PHASE VERSIONS up to 1,5 HP.
SINGLE PHASE VERSIONS from 2 HP only manual, without floater.
 - STANDARD CABLE FEATURES:
Single Phase: 10 metres H07RN-F for the standard version (automatic-manual).
Three Phase: 10 metres H07RN-F
- CUSTOMISED VOLTAGE AND FREQUENCY RATING AVAILABLE ON DEMAND
- OPTIONAL:**
- DOWN STROKE GUIDE RAIL SYSTEMS DN80 FOR FIXED PLANTS (SEE PAGE 108-109)

TABELLA MATERIALI / MATERIALS TABLE:

Pos.	Componente / Component		Materiale / Materials
A	Carcassa esterna / External housing		ACCIAIO INOX AISI 304 DIN 1.4301 / STAINLESS STEEL
B	Girante / Impeller		GHISA (G20)/CAST IRON
C	Albero (lato pompa) / Pump body		ACCIAIO INOX AISI 316 DIN 1.4401 STAINLESS STEEL
D	Tenuta meccanica Mechanical seal	Lato pompa / Pump side	CARBURO DI SILICIO-CERAMICA SILICON CARBIDE - CERAMIC
		Lato motore per Motor side for	RIVER 300F-600F GRAFITE-CERAMICA CARBIDE-CERAMIC RIVER 150F-200F ANELLO DI TENUTA NBR NBR SEAL RING
E	O-ring		NBR
G	Porta motore / Motor holder	RIVER 150F-200F	ACCIAIO INOX AISI 304 DIN 1.4301 STAINLESS STEEL
H	Carcassa motore / Motor housing	RIVER 300F-600F	
I	Coperchio + maniglia / Cover + handle		
N	Base d'appoggio / Grid holder		
P	Corpo pompa / Pump body		GHISA (G20) CAST IRON
R	Flangia portamotore inferiore / Lower motor-flange		
S	Flangia portamotore superiore / Upper motor-flange		
T	Controflangia d'aspirazione / Suction counter-flange		ACCIAIO INOX AISI 304 DIN 1.4301 STAINLESS STEEL

RIVER 150F ÷ 200F

RIVER 300F ÷ 600F

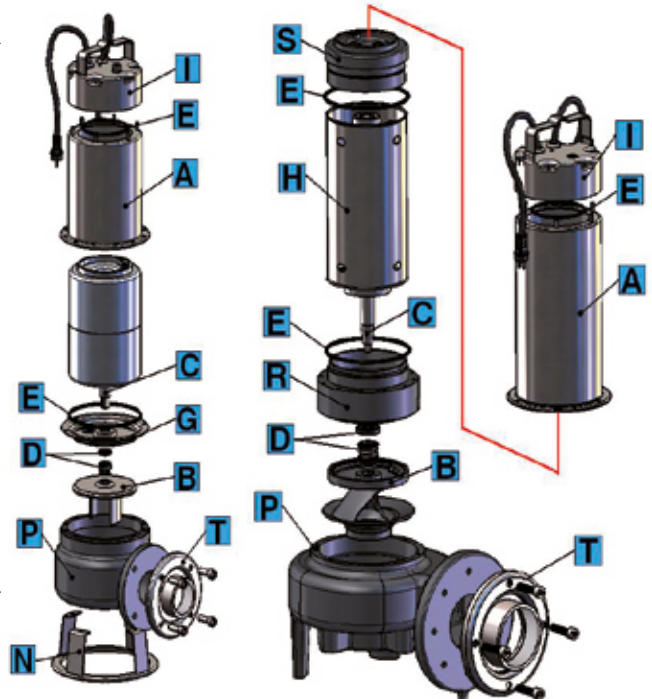

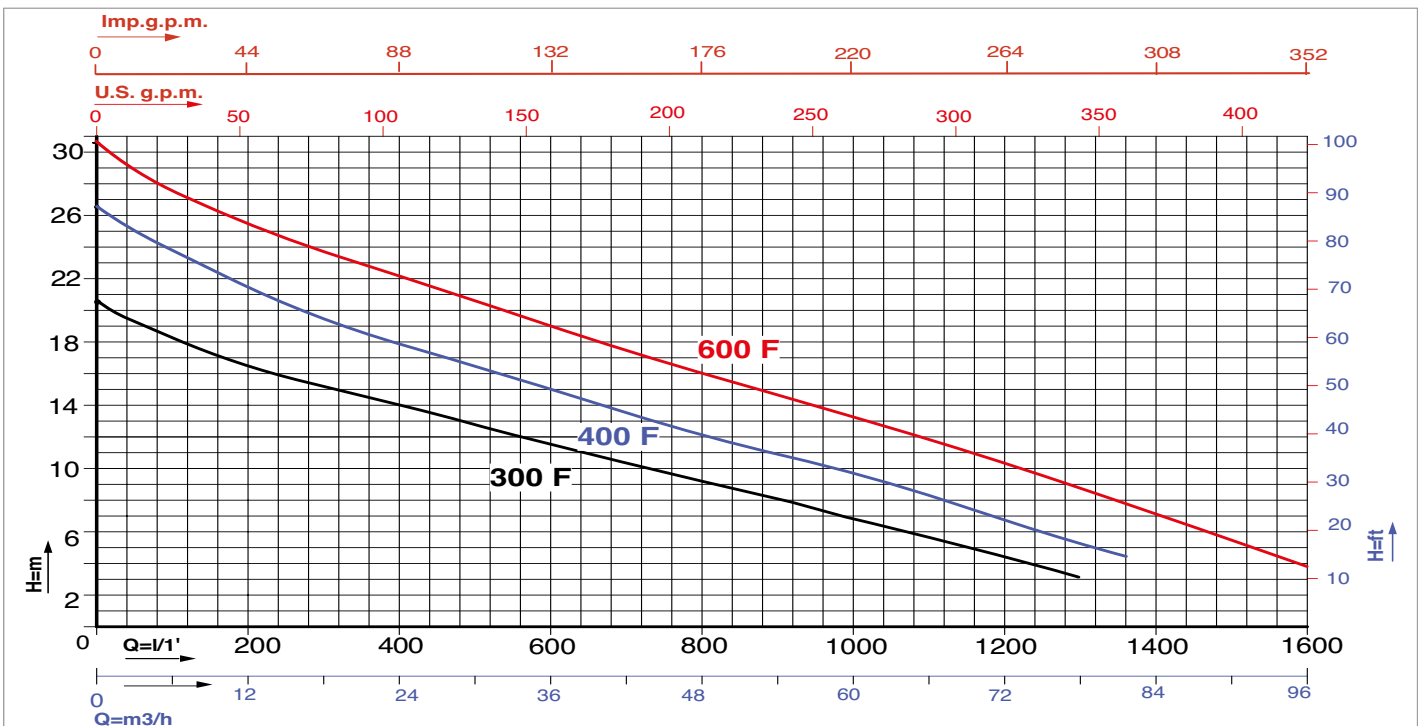
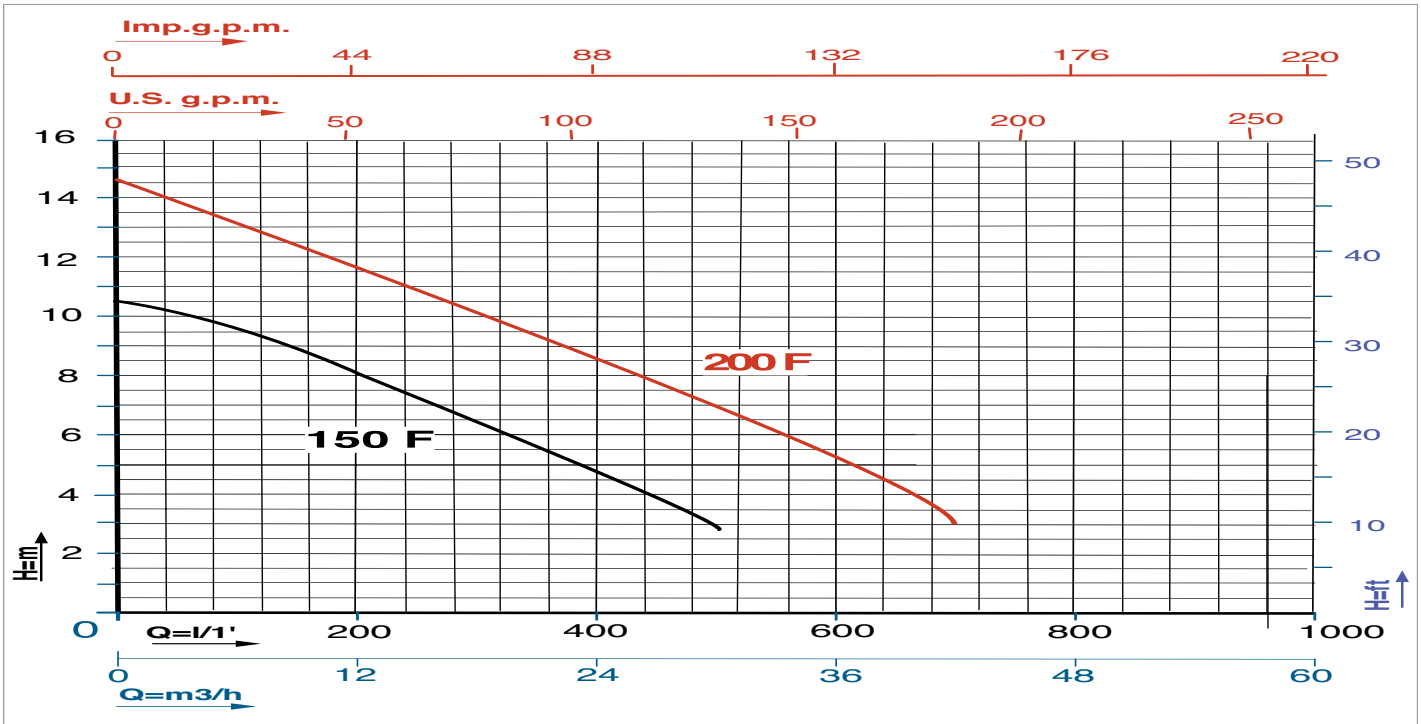

Caratteristiche di funzionamento a 2800 rpm 50Hz e 3450 rpm 60Hz - Performances at 2800 rpm 50 Hz and 3450 rpm 60 Hz
 Le prestazioni valgono per liquidi con densità $\rho = 1,0 \text{ kg/dm}^3$ ed una viscosità $\nu = 1 \text{ mm}^2/\text{s}$ / The performance data holds true for liquids with a $\rho = 1,0 \text{ kg/dm}^3$ density and a $\nu = 1 \text{ mm}^2/\text{s}$ viscosity.

MODELLO MODEL	VOLTAGGIO VOLTAGE	DATI ELETTRICI / ELECTRICAL DATA						DATI IDRAULICI / HYDRAULIC DATA										
		P1max	P2 nom.		I max	Condensatore Capacitor		m³/h		0	3	15	30	39	57	75	81	96
	50Hz	kW	kW	HP	Ampere	µF	VC	l/min.	0	50	250	500	650	950	1250	1350	1600	
RIVER 150F a M	1 x 220 - 240V	2,1	1,1	1,5	9,0	40	450	PRESSIONE TOTALE in METRI COLONNINA ACQUA / TOTAL PUMP HEAD AND WATER COLUMN HEIGHT IN m.	10,5	9,7	6,6	2,8						
RIVER 150F a T	3 x 380V - 400V	1,8	1,1	1,5	3,2	---	---		10,5	9,7	6,6	2,8						
RIVER 200F a M	1 x 220 - 240V	2,9	1,5	2,0	13,0	50	450		14,6	13,7	10,2	5,7	3,0					
RIVER 200F a T	3 x 380V - 400V	2,6	1,5	2,0	4,6	---	---		14,6	13,7	10,2	5,7	3,0					
RIVER 300F c T	3 x 380V - 400V	3,4	2,25	3,0	6,9	---	---		20,5	18,6	15,2	12,2	10,5	6,9	3,8			
RIVER 400F c T	3 x 380V - 400V	4,0	3,0	4,0	8,1	---	---		26,5	25,0	20,5	16,5	14,3	10,4	6,0	4,6		
RIVER 600F c T	3 x 380V - 400V	5,5	4,5	6,0	9,5	---	---		30,5	28,7	24,4	20,4	18,0	13,8	9,4	7,8	3,7	

DIMENSIONI e PESI / SIZE AND WEIGHT DATA:

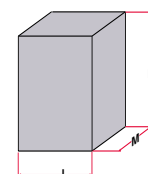
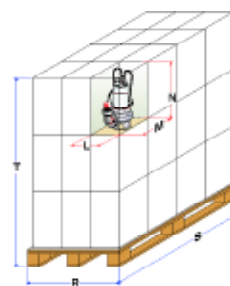
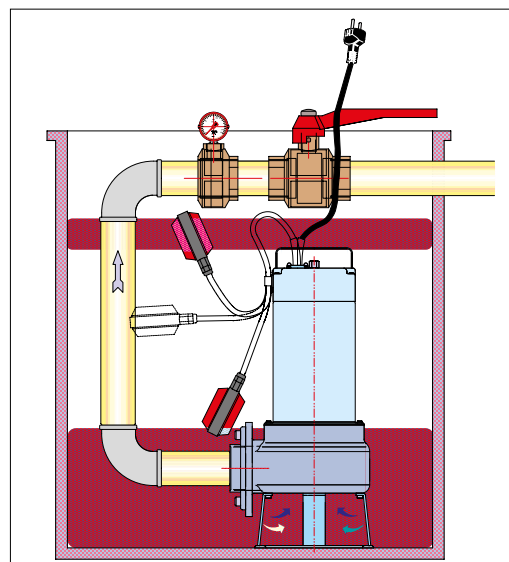
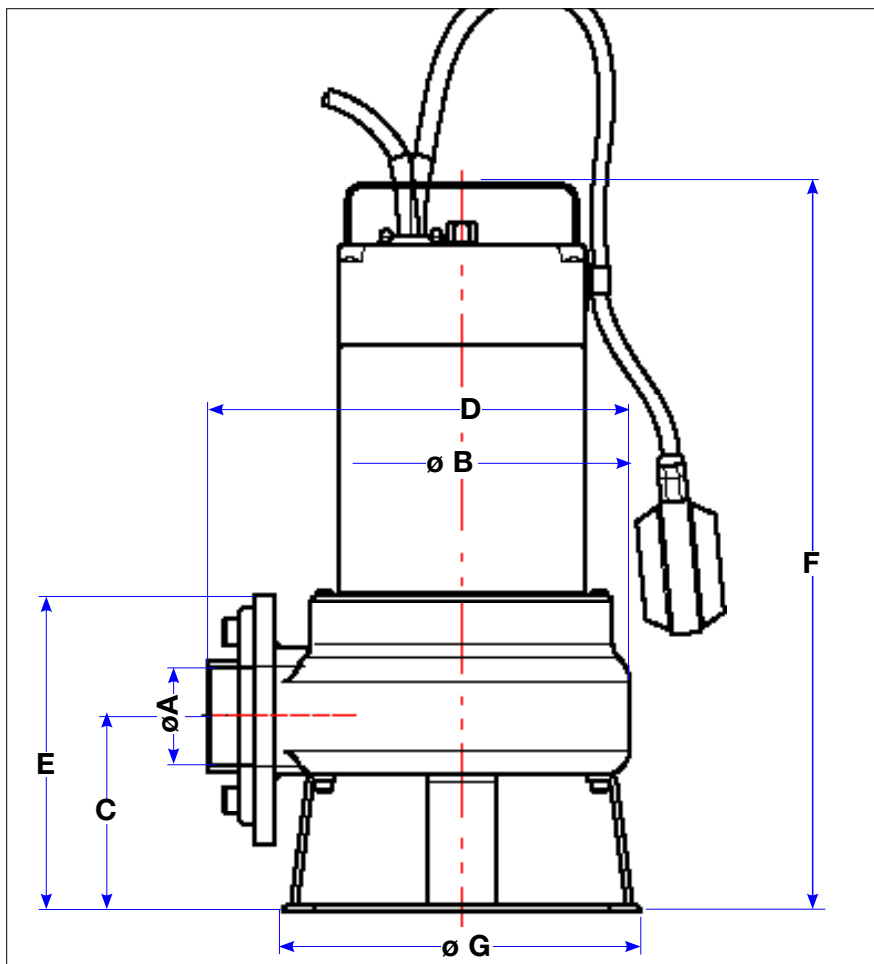

MODELLO MODEL	DIMENSIONI POMPA in mm. / PUMP DIMENSIONS in mm.						
	A	B	C	D	E	F	G
RIVER 150 F a M	2" 1/2	100	121	280,5	196	490	214
RIVER 150 F a T	2" 1/2	100	121	280,5	196	490	214
RIVER 200 F a M	2" 1/2	100	121	280,5	196	490	214
RIVER 200 F a T	2" 1/2	100	121	280,5	196	490	214
RIVER 300 F c T	3"	128	121	390	216	647	---
RIVER 400 F c T	3"	128	121	390	216	647	---
RIVER 600 F c T	3"	128	121	390	216	647	---

*..c Monocanale chiusa / Close single channel

*..a Monocanale aperta / Open single channel

MODELLO MODEL	DIMENSIONI SCATOLA / PACKING DIMENSIONS				DIMENSIONI PALLET / PALLET DIMENSIONS				
	L mm.	M mm.	N mm.	Peso / Weight Kg.	R mm.	S mm.	T mm.	nr. scatole/cartons	Peso / Weight Kg.
RIVER 150F M	260	300	530	23	800	1200	1750	36	850
RIVER 150F T	260	300	530	23	800	1200	1750	36	850
RIVER 200F M	260	300	530	28	800	1200	1750	36	1030
RIVER 200F T	260	300	530	28	800	1200	1750	36	1030
RIVER 300F T	720	400	260	53	800	1200	900	9	500
RIVER 400F T	720	400	260	54	800	1200	900	9	510
RIVER 600F T	720	400	260	55	800	1200	900	9	515

TENAX



ELETTROPOMPE SOMMERGIBILI MONOCANALI PER ACQUE CARICHE DOTATE DI CONTROFLANGIA
SUBMERSIBLE SINGLE CHANNEL ELECTRIC PUMP FOR VERY FOUL WASTE WATER, FEATURING A COUNTER FLANGE

PREVALENZA : 10,5 mt. ÷ 30,5 mt.
PORTATA : 30 m³/h ÷ 96 m³/h
POTENZA NOMINALE : 1,1 kW (1,5HP) ÷ 4,5 kW (6HP)
PASSAGGIO SOLIDI FINO A 60 mm.

PUMP HEAD : 10,5 mt ÷ 30,5 mt
DELIVERY : 30,0 m³/h ÷ 96,0 m³/h
RATED HORSEPOWER : 1,1 kW (1,5HP) ÷ 4,5 kW (6,0HP)
SOLID MATTER BYPASS up to 60 mm

APPLICAZIONI

- SVUOTAMENTO DI FOSSE DI DECANTAZIONE, POZZI DI RACCOLTA LIQUAMI.
- POMPAGGIO DI ACQUE LURIDE ANCHE CON CORPI SOLIDI E PARTI FIBROSE IN SOSPENSIONE.
- MOVIMENTAZIONE DI ACQUE LURIDE AD USO DOMESTICO E INDUSTRIALE.

APPLICATIONS

- DECANTATION PIT, SLURRY COLLECTION PIT PUMP OUT.
- LAVATORY/FOUL WATER WITH FLOATING/NON-FLOATING SOLIDS AND FIBRE SUSPENSIDS PUMP OUT.
- DOMESTIC AND INDUSTRIAL LAVATORY/BLACK WATER HANDLING SYSTEMS.

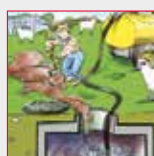

CARATTERISTICHE DI COSTRUZIONE:

- ELETTOPOMPA A DOPPIA CAMERA (MOTORE, TENUTA MECCANICA).
- ELETTOPOMPA A UNICA CAMERA (SOLO PER TENAX 400F - 600F)
- MOTORE A BAGNO D'OLIO (BIODEGRADABILE E DIELETTRICO) PER RAFFREDDAMENTO E LUBRIFICAZIONE CUSCINETTI.
- ANELLO DI TENUTA LATO MOTORE.
- TENUTA MECCANICA A BAGNO D'OLIO.
- DOPPIA TENUTA MECCANICA (SOLO PER TENAX 400F - 600F):
LATO MOTORE A BAGNO D'OLIO
LATO POMPA A BAGNO D'ACQUA
- IMMERSIONE MASSIMA: mt. 5.
- GRADO DI PROTEZIONE IP 68.
- CLASSE DI ISOLAMENTO: F
- TEMPERATURA MAX. LIQUIDO POMPATO:
25°C con pompa PARZIALMENTE immersa.
35°C con pompa TOTALMENTE immersa.
- PASSAGGIO LIBERO: 50 mm - TENAX 150 F **a**
60 mm - TENAX 200F **a**
50 mm - TENAX 300F **c**
50 mm - TENAX 400F **c**
50 mm - TENAX 600F **c**
- VERSIONI: Monofase: 220-277V/50Hz o 220-277V/60 Hz con protettore termico incorporato e condensatore permanentemente inserito.
Trifase: 220-277V/50Hz o 380-480V/50Hz e 220-277V/60Hz o 380-480V/60Hz con protezione da sovraccarico a cura dell'utente.
- POTENZA MOTORE: DA 1,5 Hp a 2 Hp VERSIONI MONOFASE E TRIFASE.
DA 3 Hp a 6 Hp solo VERSIONI TRIFASE.
- VERSIONI MONOFASI AUTOMATICHE CON GALLEGGIANTE fino a 1,5 HP.
VERSIONI MONOFASI da 2 Hp solo MANUALI SENZA GALLEGGIANTE.
- CAVO STANDARD:
Monofase: 10 metri H07RN-F per versione normale (aut.-man).
Trifase: 10 metri H07RN-F

SPECIALI VOLTAGGI E FREQUENZE A RICHIESTA.

OPTIONAL:

- SISTEMI DI DISCESA DN80 PER IMPIANTI FISSI (VEDERE PAGINA 108-109)

DESIGN ENGINEERING:

- DOUBLE CHAMBER ELECTRIC PUMP (MOTOR, MECHANICAL SEAL).
- SINGLE CHAMBER ELECTRIC PUMP (ONLY FOR TENAX 400F - 600F)
- OIL BATH MOTOR (BIODEGRADABLE AND DIELECTRIC) FOR COOLING AND BEARING LUBRICATION.
- SEALING RING - ENGINE FACE.
- OIL BATH MECHANICAL SEALS.
- DOUBLE MECHANICAL SEALS (ONLY FOR TENAX 300F):
ENGINE FACE: OIL BATH
PUMP FACE: WATER BATH
- PERMISSIBLE DRAUGHT OF WATER: 5 m
- IP 68 PROTECTION CLASS.
- CLASS "F" INSULATION.
- MAX. PUMPED LIQUID TEMPERATURE:
25°C with PRTIALLY submerged pump.
35°C with TOTALLY submerged pump.
- BY PASS SECTION: 50 mm - TENAX 150 F **a**
60 mm - TENAX 200F **a**
50 mm - TENAX 300F **c**
50 mm - TENAX 400F **c**
50 mm - TENAX 600F **c**
- VERSIONS: Single Phase: 220-277V/50Hz or 220-277V/60Hz with built in thermal protection and permanent capacitor.
Three Phase: 220-277V/50Hz or 380-480V/50Hz and 220-277V/60Hz or 380-480V/60Hz with overload protection care of the User.
- MOTOR POWER: From 1,5 HP to 2 HP single phase and three phase versions.
3 HP Only three phase versions.
- AUTOMATIC SINGLE PHASE VERSIONS up to 1,1 kW (1,5 HP).
SINGLE PHASE VERSIONS from 1.5 kW (2 HP) only manual, without floater.
- STANDARD CABLE FEATURES:
Single Phase: 10 metres H07RN-F for the standard version (automatic-manual).
Three Phase: 10 metres H07RN-F

CUSTOMISED VOLTAGE AND FREQUENCY RATING AVAILABLE ON DEMAND.

OPTIONAL:

- DOWN STROKE GUIDE RAIL SYSTEMS DN80 FOR FIXED PLANTS (SEE PAGE 108-109)

TABELLA MATERIALI / MATERIALS TABLE:

Pos.	Componente / Component	Materiale / Materials
A	Carcassa esterna / External housing	ACCIAIO INOX AISI 304 - DIN 1.4301 STAINLESS STEEL
B	Girante / Impeller	TENAX 150F-200F
		TENAX 300F-600F
C	Albero (lato pompa) / Shaft (pump side)	ACCIAIO INOX AISI 316 - DIN 1.4401 STAINLESS STEEL
D	Tenuta meccanica Mechanical seal	Lato pompa / Pump face
		Lato motore Motor face
E	O-Ring	TENAX 300F-600F
		TENAX 150F-200F
G	Porta motore / Motor holder	ACCIAIO INOX AISI 304 - DIN 1.4301 STAINLESS STEEL
H	Cassa motore / Motor housing	
I	Coperchio + maniglia / Cover + Handle	
N	Base d'appoggio / Grid holder	
P	Corpo pompa / Pump body	
R	Flangia portamotore inferiore / Lower motor-flange	GHISA (G20) CAST IRON
S	Flangia portamotore superiore / Upper motor flange	
T	Controflangia aspirazione / Suction counter-flange	ACCIAIO INOX AISI 304 - DIN 1.4301 STAINLESS STEEL

TENAX 150F - 200F

TENAX 300F - 400F - 600F

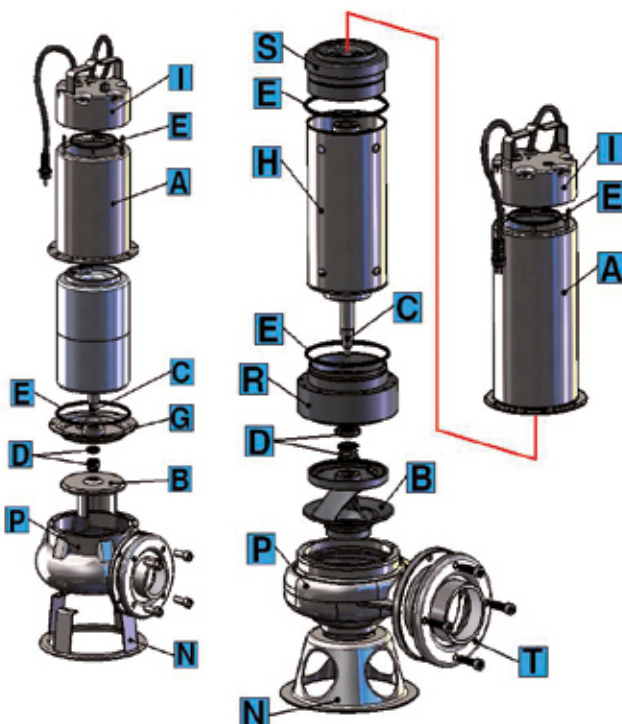

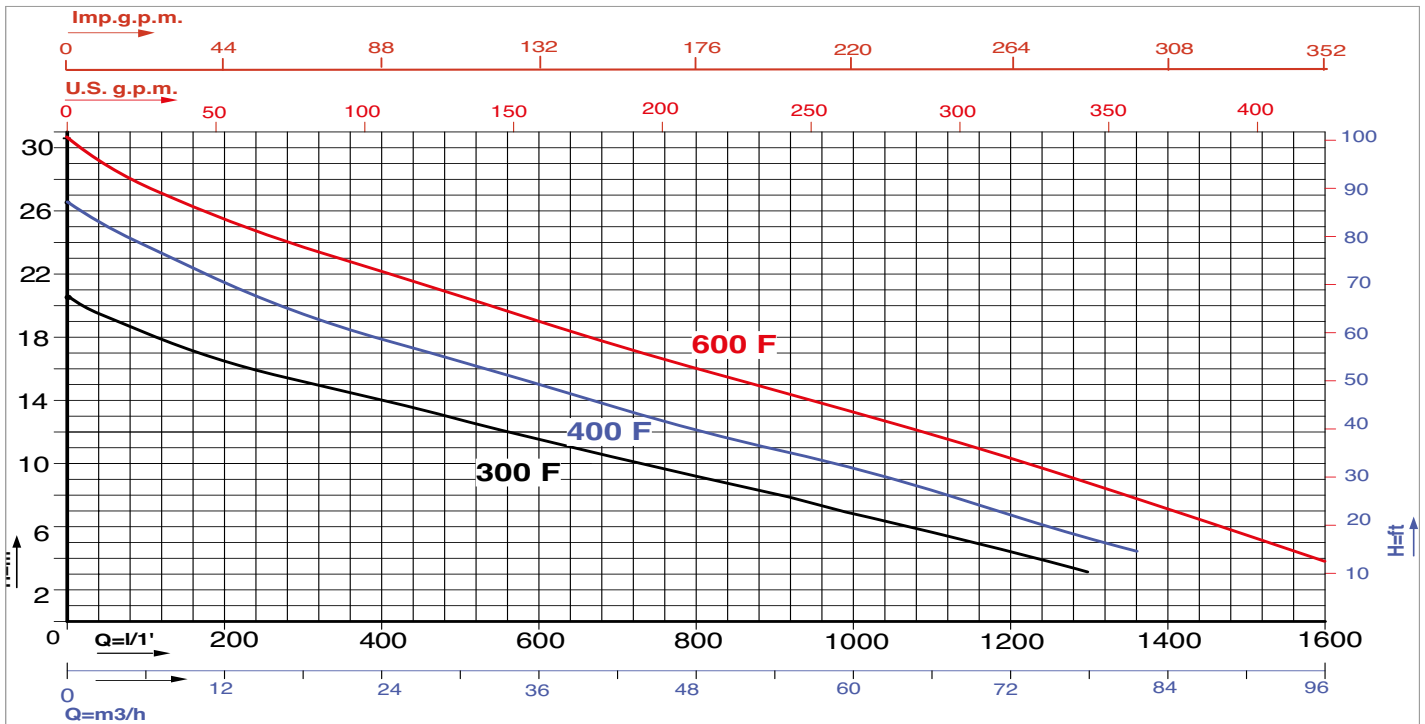
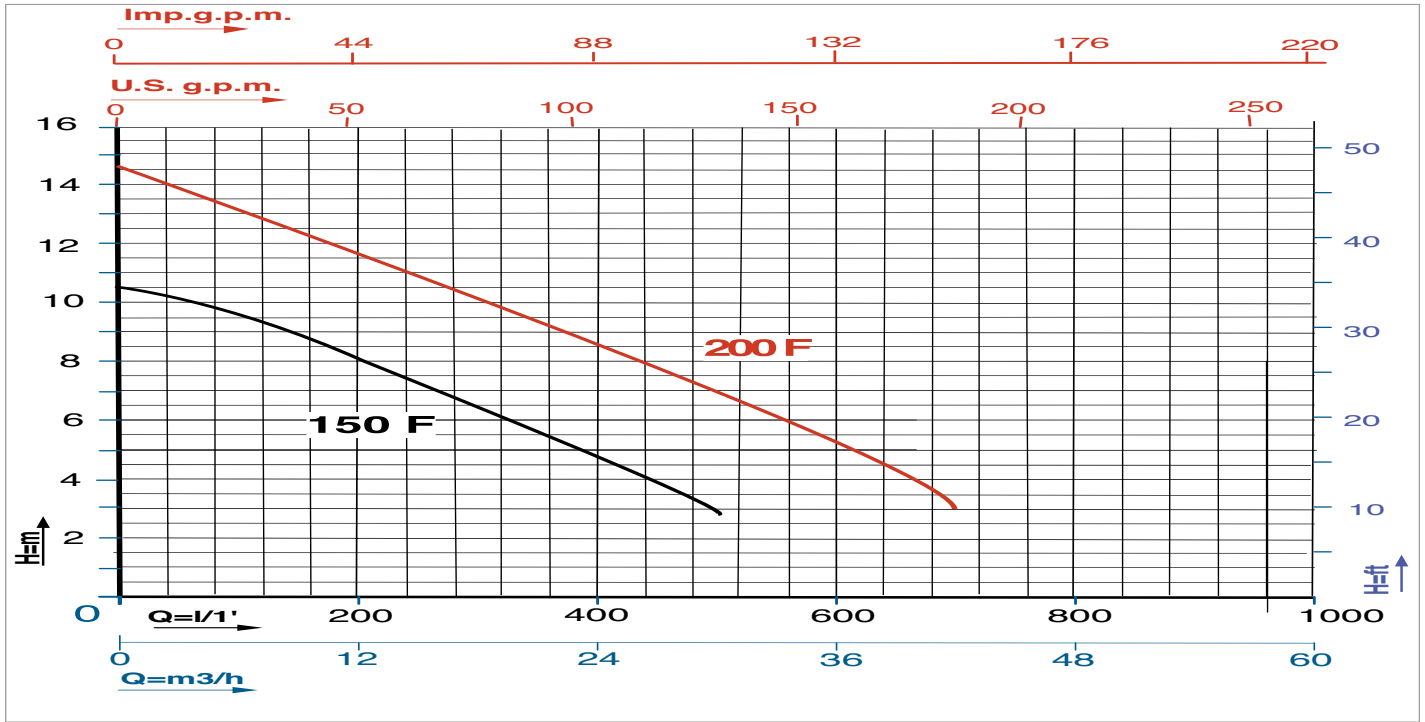

Caratteristiche di funzionamento a 2800 rpm 50Hz e 3450 rpm 60Hz - Performances at 2800 rpm 50 Hz and 3450 rpm 60 Hz
 Le prestazioni valgono per liquidi con densità $\rho = 1,0 \text{ kg/dm}^3$ ed una viscosità $\nu = 1 \text{ mm}^2/\text{s}$ / The performance data holds true for liquids with a $\rho = 1,0 \text{ kg/dm}^3$ density and a $\nu = 1 \text{ mm}^2/\text{s}$ viscosity.

Modello MODEL	VOLTAGGIO VOLTAGE 50Hz	DATI ELETTRICI / ELECTRICAL DATA						DATI IDRAULICI / HYDRAULIC DATA									
		P1 max kW	P2 nom. kW	I max HP	I max Ampere	Condensatore Capacitor		PREVALENZA TOTALE IN METRI / TOTAL PUMP HEAD AND WATER COLUMN HEIGHT IN Ft.									
						μF	VC	m³/h	0	3	15	30	39	57	72	81	96
TENAX 150F a M	1 x 220-240V	2,1	1,1	1,5	9,0	40	450	l/min.	0	50	250	500	650	950	1200	1350	1600
TENAX 150F a T	3x 380 - 400V	1,8	1,1	1,5	3,2	---	---	H (m)	10,5	9,7	6,6	2,8					
TENAX 200F a M	1 x 220-240V	2,9	1,5	2,0	13	40	450		10,5	9,7	6,6	2,8					
TENAX 200F a T	3x 380 - 400V	2,6	1,5	2,0	4,6	---	---		14,5	13,7	10,2	5,7	3,0				
TENAX 300F c T	3x 380 - 400V	3,4	2,25	3,0	6,9	---	---		20,5	18,6	15,2	12,2	10,5	6,9	3,8		
TENAX 400F c T	3x 380 - 400V	4,0	3,0	4,0	8,1	---	---		26,5	25,0	20,5	16,5	14,3	10,4	6,0	4,6	
TENAX 600F c T	3x 380 - 400V	5,5	4,5	6,0	9,5	---	---		30,5	28,7	24,4	20,4	18,0	13,8	9,4	7,8	3,7

DIMENSIONI e PESI / SIZE AND WEIGHT DATA:

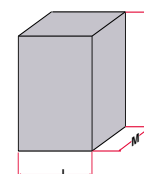
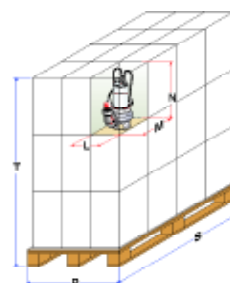
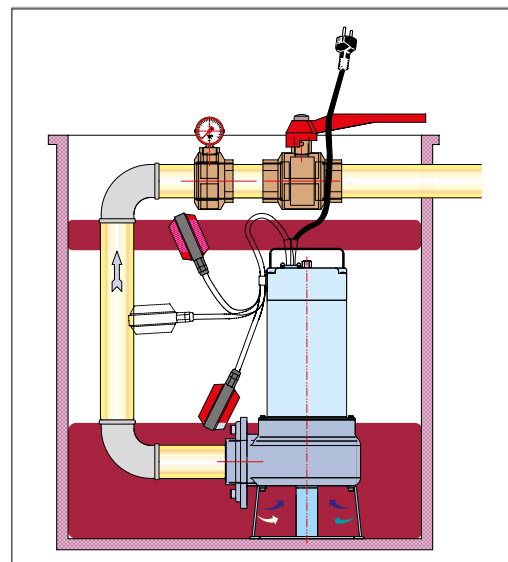
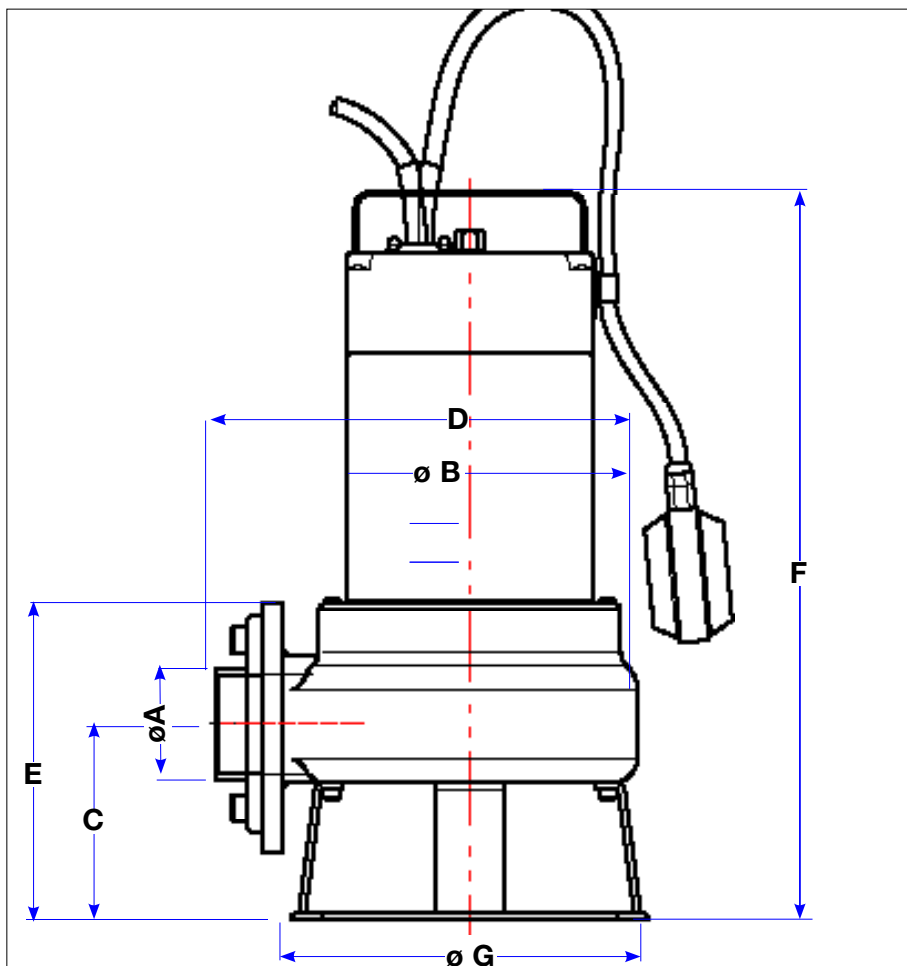

MODELLO MODEL	DIMENSIONI POMPA in mm. / PUMP DIMENSIONS in mm.						
	A	B	C	D	E	F	G
TENAX 150F a M	2" 1/2	115	116,5	260	192	473	214
TENAX 150F a M	2" 1/2	115	116,5	260	192	473	214
TENAX 200F a M	2" 1/2	115	116,5	260	192	473	214
TENAX 200F a T	2" 1/2	115	116,5	260	192	473	214
TENAX 300F c T	3"	119	190	390	285	662	279
TENAX 400F c T	3"	119	190	390	285	662	279
TENAX 600F c T	3"	119	190	390	285	662	279

*..c Monocanale chiusa / Close single channel

*..a Monocanale aperta / Open single channel

MODELLO MODEL	DIMENSIONI SCATOLA / PACKING DIMENSIONS				DIMENSIONI PALLET / PALLET DIMENSIONS				
	L mm.	M mm.	N mm.	Peso / Weight Kg.	R mm.	S mm.	T mm.	nr. scatole/cartons	Peso / Weight Kg.
TENAX 150F a M	260	300	530	19	800	1200	1750	36	709
TENAX 150F a T	260	300	530	19	800	1200	1750	36	709
TENAX 200F a M	260	300	530	22,5	800	1200	1750	36	835
TENAX 200F a T	260	300	530	22,5	800	1200	1750	36	835
TENAX 300F c T	720	400	260	28	800	1200	900	9	280
TENAX 400F c T	720	400	260	33	800	1200	900	9	325
TENAX 600F c T	720	400	260	37	800	1200	900	9	360

CUTTER



ELETTROPOMPE SOMMERGIBILI TRITURATRICI PER ACQUE SPORCHE E CARICHE SUBMERSIBLE ELECTRIC GRINDER PUMPS FOR FOUL AND HEAVY WASTE WATER

PREVALENZA : 16,5 mt. ÷ 23,5 mt.
PORTATA : 9 m³/h ÷ 21 m³/h
POTENZA NOMINALE : 1,1 kW (1,5HP) ÷ 2,25 kW (3HP)

PUMP HEAD : 16,5 mt ÷ 23,5 mt
DELIVERY : 9,0 m³/h ÷ 21,0 m³/h
RATED HORSEPOWER : 1,1 kW (1,5HP) ÷ 2,25 kW (3,0HP)

APPLICAZIONI

- POMPAGGIO E TRITURAZIONE DI ACQUE LURIDE CON CORPI SOLIDI E PARTI FIBROSE
- SVUOTAMENTO DI FOSSE DI DECANTAZIONE POZZI NERI POZZI DI RACCOLTA LIQUAMI
- MOVIMENTAZIONE DI ACQUE LURIDE AD USO DOMESTICO E INDUSTRIALE

APPLICATIONS

- GRINDING AND PUMP OUT OF LAVATORY/FOUL WATER WITH FLOATING SOLIDS AND FIBRE SUSPENSIDS .
- DECANTATION PIT, SEWAGE PIT AND SLURRY COLLECTION PIT PUMP OUT
- DOMESTIC AND INDUSTRIAL LAVATORY/BLACK WATER HANDLING SYSTEMS.

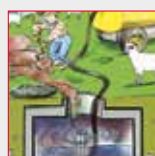

CARATTERISTICHE DI COSTRUZIONE:

- ELETTOPOMPA A DOPPIA CAMERA (MOTORE, TENUTA MECCANICA).
- MOTORE A BAGNO D'OLIO (BIODEGRADABILE E DIELETTRICO)PER RAFFREDDAMENTO E LUBRIFICAZIONE CUSCINETTI.
- ANELLO DI TENUTA LATO MOTORE.
- DOPPIA TENUTA MECCANICA: LATO MOTORE A BAGNO D'OLIO.(ESCLUSA CUTTER 140) LATO POMPA A BAGNO D'ACQUA.
- IMMERSIONE MASSIMA: mt. 5.
- GRADO DI PROTEZIONE IP 68.
- CLASSE DI ISOLAMENTO: F
- TEMPERATURA MAX.LIQUIDO POMPATO: 25°C PARZIALMENTE immersa
35°C TOTALMENTE immersa
- VERSIONI: Monofase: 220-277V/50Hz o 220-277V/60Hz con protettore termico incorporato e condensatore permanentemente inserito. (CUTTER140)
Trifase: 220-277V/50Hz o 380-480V/50Hz e 220-277V/60Hz o 380-480V/60Hz con protezione da sovraccarico a cura dell'utente.
- POTENZA MOTORE: DA 1,5 Hp a 2 Hp VERSIONI MONOFASE E TRIFASE.
DA 3 Hp solo VERSIONI TRIFASE.
- VERSIONI MONOFASI AUTOMATICHE SOLO FINO A 1,5 Hp.
- CAVO STANDARD:
Monofase: 10 metri H07RN-F completa di quadro elettrico con spezzone 0,7metri senza spina.
Trifase: 10 metri H07RN-F.

SPECIALI VOLTAGGI E FREQUENZE A RICHIESTA.

OPTIONAL:

- SISTEMI DI DISCESA DN50 PER IMPIANTI FISSI (VEDERE PAGINA 108)

DESIGN ENGINEERING:

- DOUBLE CHAMBER ELECTRIC PUMP (MOTOR, MECHANICAL SEAL).
- OIL BATH MOTOR (BIODEGRADABLE AND DIELECTRIC) FOR COOLING AND BEARING LUBRICATION.
- SEALING RING - ENGINE FACE.
- DOUBLE MECHANICAL SEALS: ENGINE FACE: OIL BATH.(ESCLUDED CUTTER 140) PUMP FACE: WATER BATH.
- PERMISSIBLE DRAUGHT OF WATER: 5 m
- IP 68 PROTECTION CLASS.
- CLASS "F" INSULATION.
- MAX. PUMPED LIQUID TEMPERATURE:
25°C with PARTIALLY submerged pump.
35°C with TOTALLY submerged pump.
- VERSIONS: Single Phase: 220-277V/50Hz or 220-277V/60Hz with built in thermal protection and permanent capacitor. (CUTTER 140)
Three Phase: 22-277V/50Hz or 380-480V/50Hz and 220-277V/60Hz or 380-480V/60Hz with overload protection care of the User.
- MOTOR POWER: From 1,5 HP to 2 HP single phase and three phase versions.
From 3 HP only three phase versions.
- AUTOMATIC SINGLE PHASE VERSIONS ONLY UP TO 1.5 HP.
- STANDARD CABLE FEATURES:
Single Phase: 10 metres H07RN-F complete with power supply box 0,7m cable section, without connection plug.
Three Phase: 10 metres H07RN-F.

CUSTOMISED VOLTAGE AND FREQUENCY RATING AVAILABLE ON DEMAND.

OPTIONAL:

- DOWN STROKE GUIDE RAIL SYSTEMS DN50 FOR FIXED PLANTS (SEE PAGE 108)

TABELLA MATERIALI / MATERIALS TABLE:

Pos.	Componente / Component		Materiale / Materials
A	Carcassa esterna / External housing		ACCIAIO INOX AISI 304 - DIN 1.4301 STAINLESS STEEL
B	Girante / Impeller		GHISA G20 / CAST IRON
C	Albero (lato pompa) / Shaft (pump side)		ACCIAIO INOX AISI 316 - DIN 1.4401 STAINLESS STEEL
D	Tenuta meccanica Mechanical seal	Lato pompa / Pump face	CARBURO DI SILICIO-CERAMICA SILICON CARBIDE-CERAMIC
		Lato motore Motor face	CUTTER 140 ANELLO DI TENUTA NBR NBR SEAL RING CUTTER 150-200-300 GRAFITE - CERAMICA GRAPHITE - CERAMIC
E	O-Ring		NBR
I	Coperchio + maniglia / Cover + handle		ACCIAIO INOX AISI 304 - DIN 1.4301 STAINLESS STEEL
L	Diffusore / Pump body		GHISA (G20) CAST IRON
P	Corpo pompa / Pump body		
N	Base d'appoggio / Grid holder		ACCIAIO INOX AISI 304 - DIN 1.4301 STAINLESS STEEL
Z	Sistema trituratore / Grinder system		ACCIAIO INOX AISI 440C - DIN 1.4125 STAINLESS STEEL

CUTTER 140

CUTTER 150-200-300

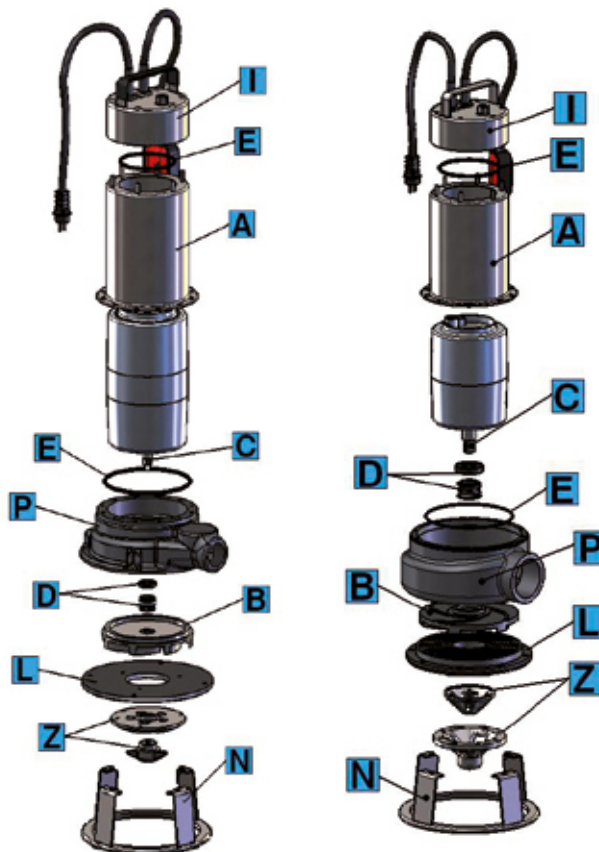

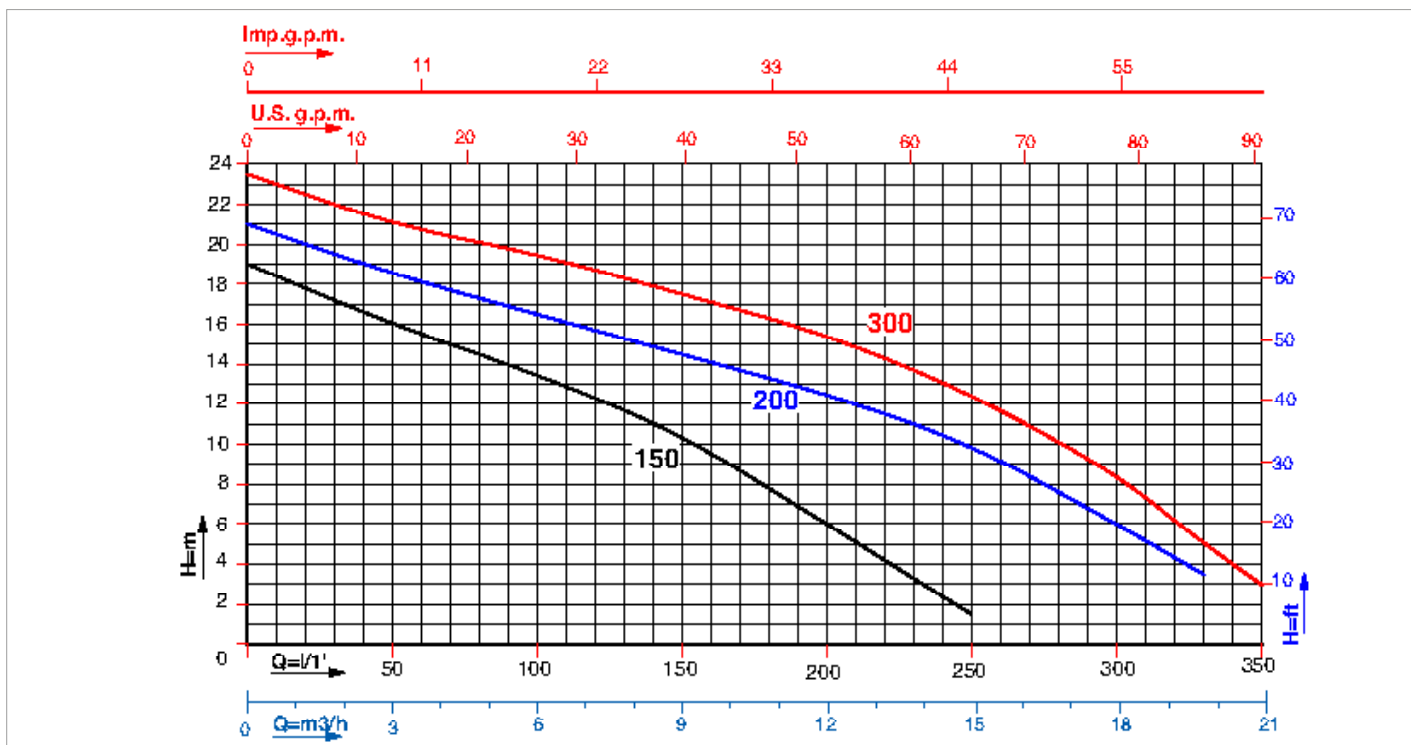
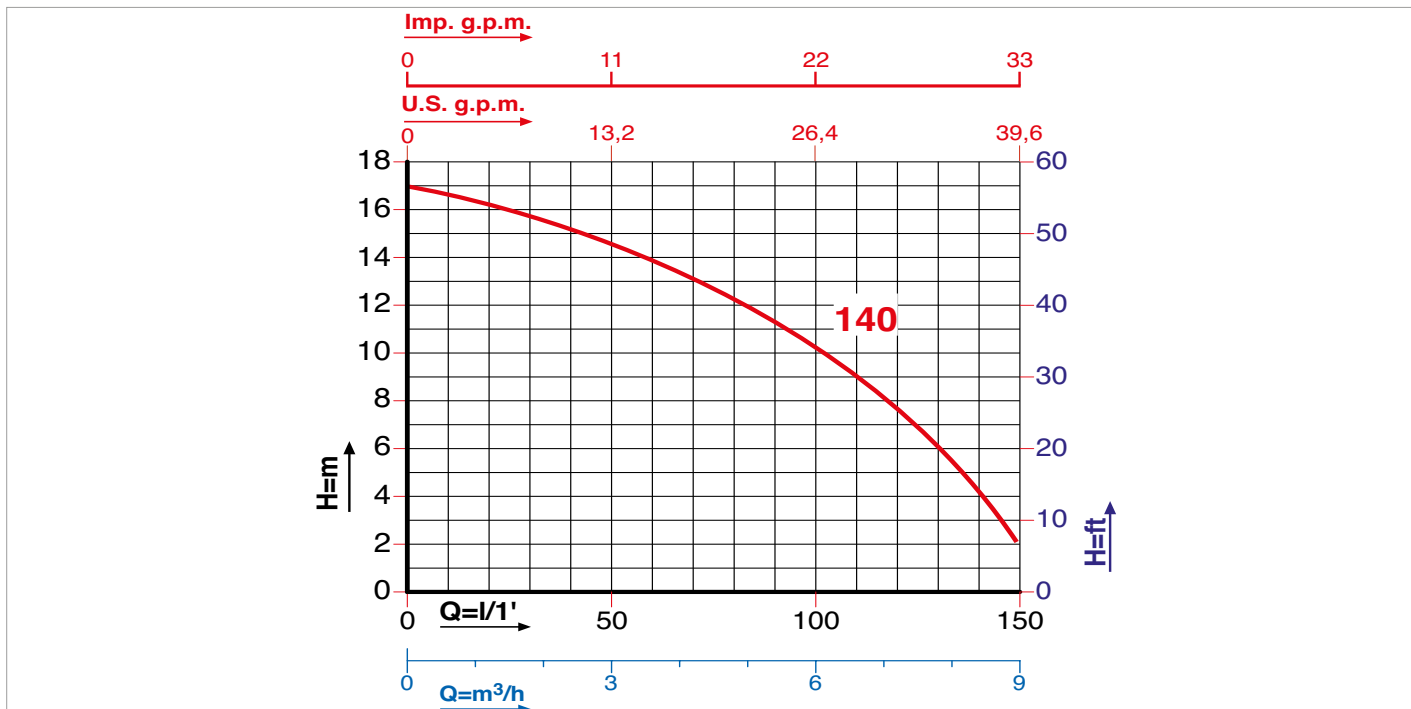

Caratteristiche di funzionamento a 2800 rpm 50Hz e 3450 rpm 60Hz - Performances at 2800 rpm 50 Hz and 3450 rpm 60 Hz
 Le prestazioni valgono per liquidi con densità $\rho = 1,0 \text{ kg/dm}^3$ ed una viscosità $\nu = 1 \text{ mm}^2/\text{s}$ / The performance data holds true for liquids with a $\rho = 1,0 \text{ kg/dm}^3$ density and a $\nu = 1 \text{ mm}^2/\text{s}$ viscosity.

MODELLO MODEL	VOLTAGGIO VOLTAGE 50 Hz	DATI ELETTRICI / ELECTRICAL DATA					DATI IDRAULICI / HYDRAULIC DATA										
		P1 max kW	P2 nom. kW	I max HP	I max Ampere	Condensatore Capacitor μF VC	m^3/h	0	3	6	9	12	15	18	19,8	21	
CUTTER 140 M	1 x 220-230V	1,6	1,1	1,5	7,1	30	450	H (m)	17,0	14,5	10,0	2,0					
CUTTER 140 T	3 x 380-400V	1,3	1,1	1,5	3,0	---	---		17,0	14,5	10,0	2,0					
CUTTER 150 M	1 x 220-230V	2,2	1,1	1,5	10,5	80	450	H (m)	19,0	16,0	13,5	10,5	6,0	1,5			
CUTTER 150 T	3 x 380-400V	2,0	1,1	1,5	4,0	---	---		19,0	16,0	13,5	10,5	6,0	1,5			
CUTTER 200 M	1 x 220-230V	2,9	1,5	2,0	13,0	80	450	H (m)	21,0	18,5	16,5	14,5	12,5	10,0	6,0	3,5	
CUTTER 200 T	3 x 380-400V	2,5	1,5	2,0	4,5	---	---		21,0	18,5	16,5	14,5	12,5	10,0	6,0	3,5	
CUTTER 300 T	3 x 380-400V	3,4	2,25	3,0	6,0	---	---	23,5	21,0	19,5	17,5	15,5	12,5	8,5	5,0	3,0	

DIMENSIONI e PESI / SIZE AND WEIGHT DATA:

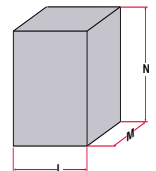
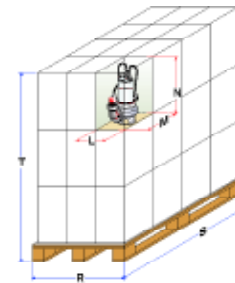
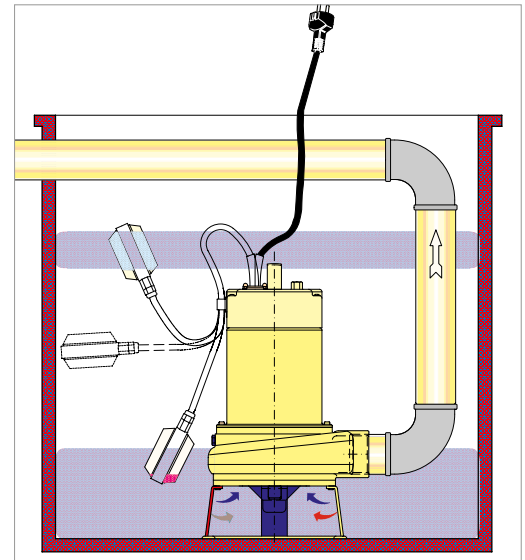
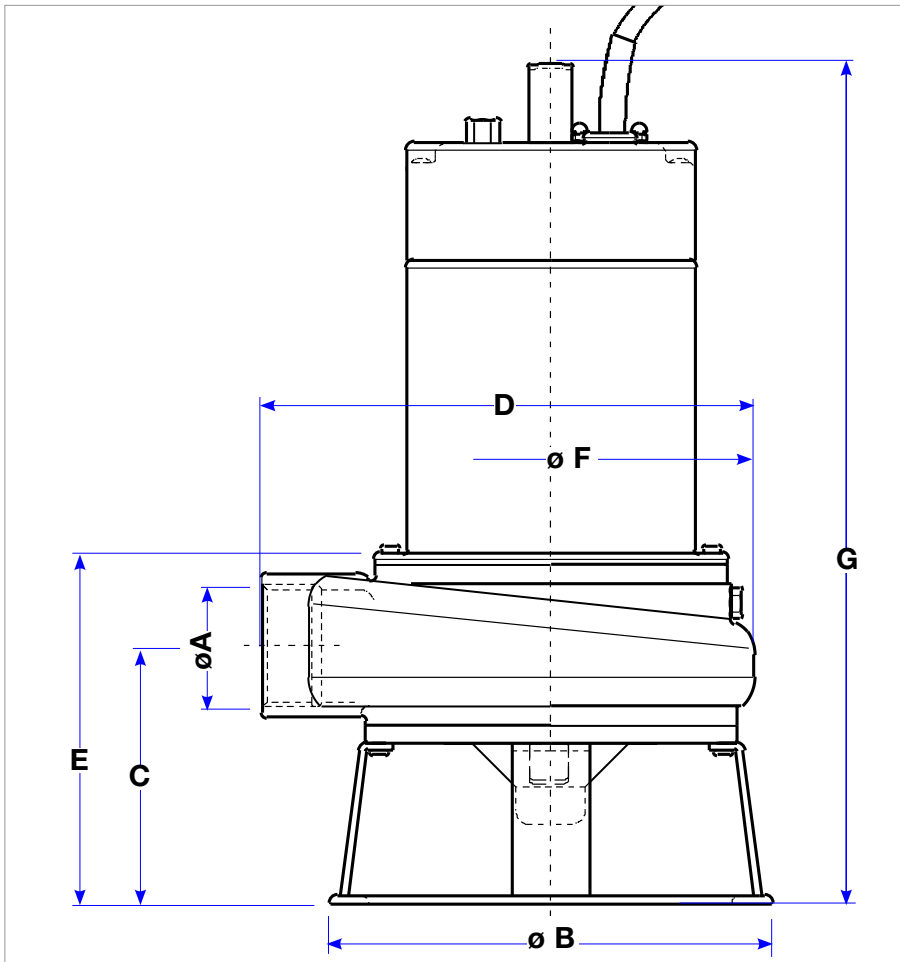

MODELLO / MODEL	DIMENSIONI POMPA in mm. / PUMP DIMENSIONS in mm.						
	A	B	C	D	E	F	G
CUTTER 140 M	1" 1/2	225	102,5	213,5	126	156	356
CUTTER 140 T	1"1/2	225	102,5	213,5	126	156	356
CUTTER 150 M	2"	225	131,5	260	165	215	425
CUTTER 150 T	2"	225	131,5	260	165	215	425
CUTTER 200 M	2"	225	131,5	260	165	215	425
CUTTER 200 T	2"	225	131,5	260	165	215	425
CUTTER 300 T	2"	225	131,5	260	165	215	425

MODELLO / MODEL	DIMENSIONI SCATOLA / PACKING DIMENSIONS				DIMENSIONI PALLET / PALLET DIMENSIONS				
	L mm.	M mm.	N mm.	Peso / Weight Kg.	R mm.	S mm.	T mm.	nr. scatole/cartons	Peso / Weight Kg.
CUTTER 140 M	260	320	340	21	800	1200	1400	36	771
CUTTER 140 T	260	320	340	21	800	1200	1400	36	771
CUTTER 150 M	260	300	530	25,5	800	1200	1750	36	933
CUTTER 150 T	260	300	530	25,5	800	1200	1750	36	933
CUTTER 200 M	260	300	530	28,5	800	1200	1750	36	1050
CUTTER 200 T	260	300	530	28,5	800	1200	1750	36	1050
CUTTER 300 T	260	300	530	29	800	1200	1750	36	1070

ROXY



ELETTROPOMPE SOMMERSIBILI MULTISTADIO VERTICAL SUBMERSIBLE SINGLE-BLOCK MULTISTAGE

PREVALENZA : 31,0 ÷ 38,0 mt.
PORTATA : 4,5 ÷ 6,5 m³/h
POTENZA NOMINALE : 0,55 kW (0,75 HP) ÷ 0,6 kW (0,85 HP)

PUMP HEAD : 31,0 ÷ 38,0 mt
DELIVERY : 4,5 ÷ 6,5 m³/h
RATED HORSEPOWER : 0,55 kW (0,75 HP) ÷ 0,6 kW (0,85 HP)

APPLICAZIONI

- SVUOTAMENTO DA ACQUE PIOVANE, D'INFILTRAZIONE, DI POZZETTI O VASCHE DI RACCOLTA.
- PRELIEVO DA VASCHE DI RACCOLTA DI ACQUE PIOVANE PER PICCOLE IRRIGAZIONI A SCORRIMENTO DI ORTI E DI GIARDINI.
- TRAVASO DI ACQUA CHIARA DA SERBATOI E VASCHE.

APPLICATIONS

- RAIN, SEEPAGE, SUMP PIT AND CATCH TANK WATER PUMP OUT.
- GARDEN AND VEGETABLE-GARDEN MINI FLOOD IRRIGATION SYSTEM RAINWATER CATCH TANK PUMP DOWN.
- WHITE WATER PUMP OVER FROM RESERVOIRS AND VATS.

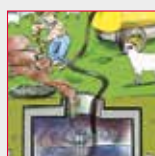

CARATTERISTICHE DI COSTRUZIONE:

- MOTORE A SECCO RAFFREDDATO DAL LIQUIDO POMPATO
- DOPPIA TENUTA MECCANICA: DOPPIO ANELLO DI TENUTA LATO MOTORE, TENUTA MECCANICA A BAGNO D'OLIO LATO POMPA
- IMMERSIONE MASSIMA: mt. 10.
- GRADO DI PROTEZIONE IP 68.
- CLASSE DI ISOLAMENTO: F
- TEMPERATURA MAX.LIQUIDO POMPATO: 35°C
- VERSIONI: Monofase: 220-277V/50Hz o 220-277V/60Hz con protettore termico incorporato e condensatore permanentemente inserito.
- CAVO STANDARD:
Monofase: 10 metri H07RN-F per versione normale (aut.-man).

SPECIALI VOLTAGGI E FREQUENZE A RICHIESTA.

DESIGN ENGINEERING:

- SEMI WET MOTOR WATERCOOLED
- DOUBLE MECHANICAL SEAL: DOUBLE SEAL RING -ENGINE FACE
OIL BATH MECHANICAL SEALS PUMP FACE
- PERMISSIBLE DRAUGHT OF WATER: 10 m
- IP 68 PROTECTION CLASS.
- CLASS "F" INSULATION.
- MAX. PUMPED LIQUID TEMPERATURE: 35°C
- VERSIONS: Single Phase: 220-277V/50Hz or 220-277V/60Hz with built in thermal protection and permanent capacitor.
- STANDARD CABLE FEATURES:
Single phase :10 metres H07RN-F for the standard version (automatic-manual).

CUSTOMISED VOLTAGE AND FREQUENCY RATING AVAILABLE ON DEMAND.

TABELLA MATERIALI - MATERIALS TABLE:

Pos.	Componente -Component	Materiale - Materials	
A	Carcassa esterna / External motor housing	ACCIAIO INOX AISI 304 - DIN 1.4301 / STAINLESS STEEL	
B	Girante / Impeller	TECNOPOLIMERO TECNOPOLYMER	
C	Albero (lato pompa) / Shaft (pump side)	ACCIAIO INOX AISI 303 - DIN 1.4005 / STAINLESS STEEL	
D	Tenuta meccanica Mechanical seal	Lato motore / Motor face	DOPPIO ANELLO DI TENUTA NBR NBR DOUBLE SEALING RING
		Lato pompa / Pump face	GRAFITE-CERAMICA GRAPHITE - CERAMIC
E	O-ring	NBR	
F	Porta tenuta / Seal holder	ACCIAIO INOX AISI 304 - DIN 1.4301 / STAINLESS STEEL	
G	Porta motore / Motor holder	TECNOPOLIMERO TECNOPOLYMER	
H	Cassa motore / Motor housing	ACCIAIO INOX AISI 304 - DIN 1.4301 / STAINLESS STEEL	
I	Coperchio / Cover	TECNOPOLIMERO TECNOPOLYMER	
K	Distanziale / Spacer	NORYL	
L	Diffusori / Diffusers	TECNOPOLIMERO TECNOPOLYMER	
N	Base d'aspirazione / Suction base	ACCIAIO INOX AISI 304 - DIN 1.4301 / STAINLESS STEEL	
Y	Piatto diffusori / Diffusers plate	FERRO / STEEL	

ROXY 75 - 85



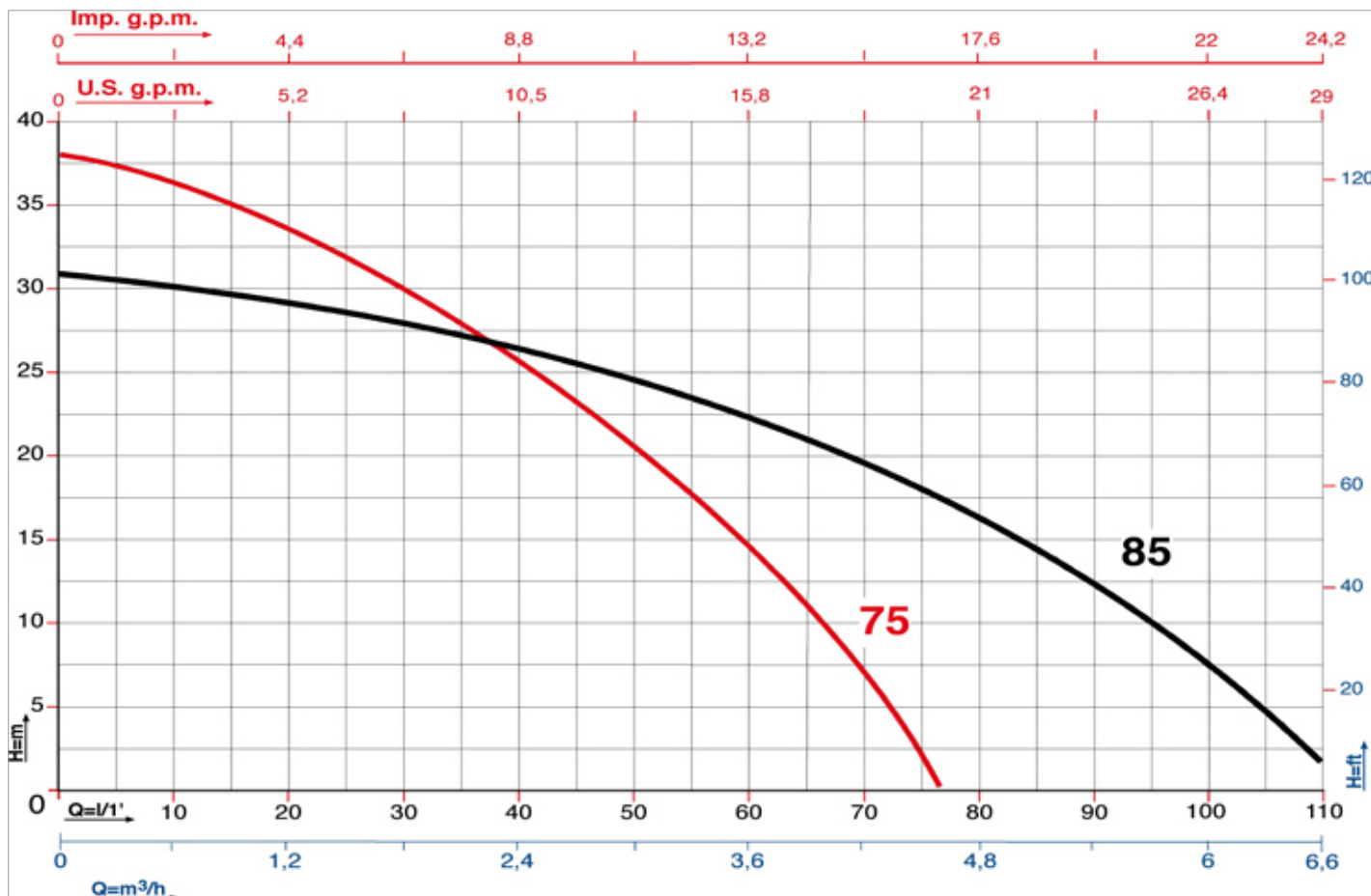

Caratteristiche di funzionamento a 2800 rpm 50Hz e 3450 rpm 60Hz - Performances at 2800 rpm 50 Hz and 3450 rpm 60 Hz
 Le prestazioni valgono per liquidi con densità $\rho = 1,0 \text{ kg/dm}^3$ ed una viscosità $\nu = 1 \text{ mm}^2/\text{s}$ / The performance data holds true for liquids with a $\rho = 1,0 \text{ kg/dm}^3$ density and a $\nu = 1 \text{ mm}^2/\text{s}$ viscosity.

MODELLO / MODEL	VOLTAGGIO VOLTAGE 50Hz	DATI ELETTRICI / ELECTRICAL DATA						DATI IDRAULICI / HYDRAULIC DATA										
		P1 max	P2 nom			I max	Condensatore Capacitor	m ³ /h										
			kW	kW	HP				Ampere	μF	VC	I/ min.	0	1	2	3	4	4,5
ROXY 75 M	1 x 220-230V	0,95	0,55	0,75	4,2	16	450	H (m)	38	34	28,5	20,5	10	2,5	---	---	---	
ROXY 85 M	1 x 220-230V	1,05	0,6	0,85	5,0	16	450	H (m)	31	30	28	25	20	17,5	15	7,5	2,5	

PREVALENZA TOTALE in METRI COLONNA ACQUA
 TOTAL PUMP HEAD AND WATER COLUMN HEIGHT IN m.

DIMENSIONI E PESI / SIZE AND WEIGHT DATA :

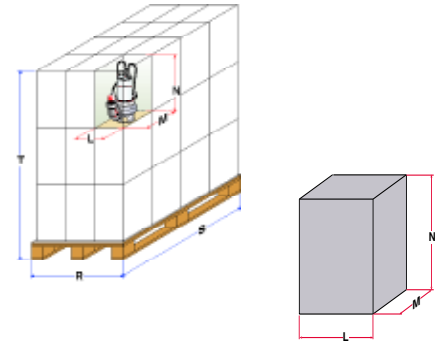
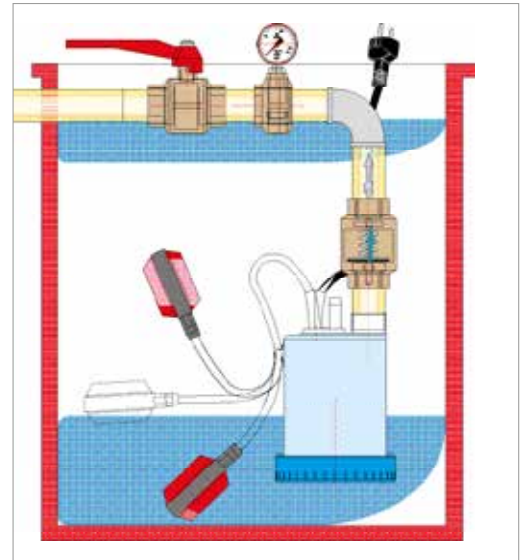
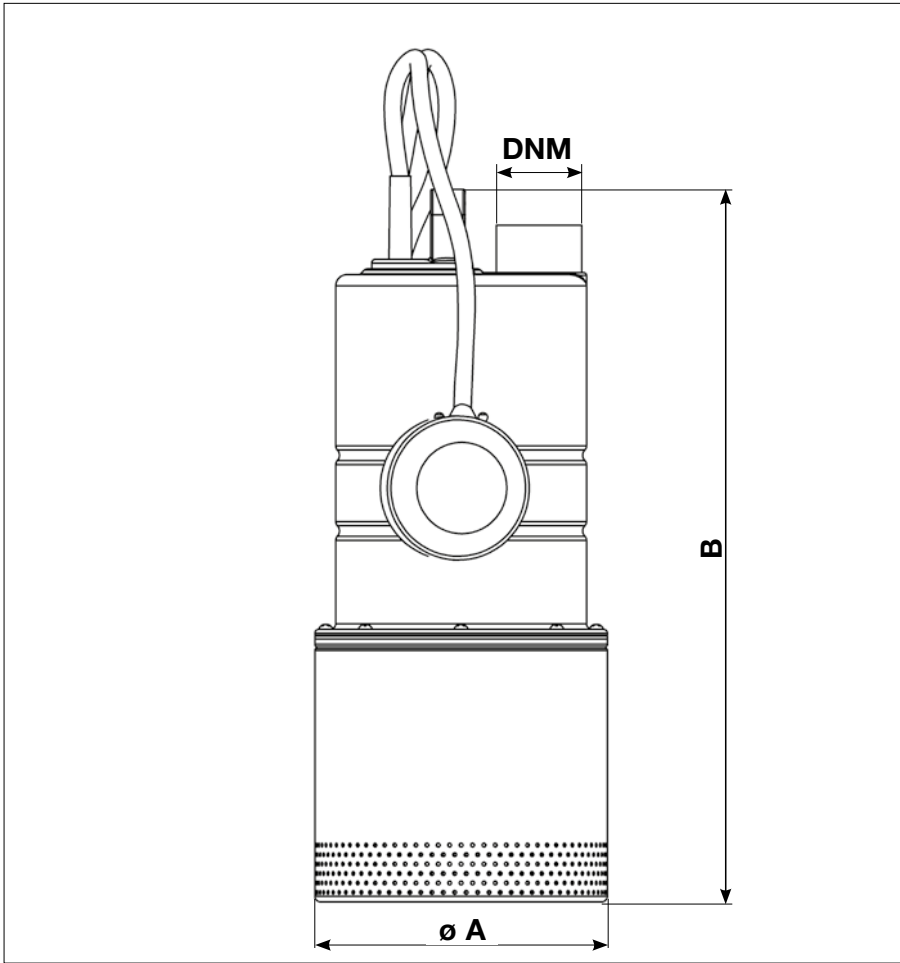

MODELLO / MODEL	DIMENSIONE POMPA in mm. / PUMP DIMENSION in mm.		
	DNM	A	B
ROXY 75 M	1" 1/4	154	376,5
ROXY 85 M	1" 1/4	154	376,5

MODELLO MODEL	DIMENSIONI SCATOLA / PACKING DIMENSIONS				DIMENSIONI PALLET / PALLET DIMENSIONS				
	L mm	M mm	N mm	PESO/Weight kg	R mm	S mm	T mm	nr. scatole/cartoons	Peso/ Weight Kg
ROXY 75 M	220	290	415	8,0	800	1200	1810	80	655
ROXY 85 M	220	290	415	8,0	800	1200	1810	80	655

ROXY



ELETTROPOMPE SOMMERGIBILI MONOBLOCCO MULTISTADIO VERTICALI, PER POZZI DA 5" VERTICAL SUBMERSIBLE SINGLE BLOCK MULTI STAGE ELECTRIC PUMPS, FOR 5 INCH WELLS

PREVALENZA : 34 mt. ÷ 73 mt.
PORTATA : 5,4 m³/h
POTENZA NOMINALE : 0,6 kW (0,8 HP) ÷ 1,2 kW (1,6 HP)

PUMP HEAD : 34 mt ÷ 73 mt
DELIVERY : 5,4 m³/h
RATED HORSEPOWER : 0,6 kW (0,8 HP) ÷ 1,2 kW (1,6 HP)

APPLICAZIONI

- IMPIANTI PER LA MOVIMENTAZIONE DI ACQUE NEI SETTORI CIVILE ED INDUSTRIALE
- IMPIANTI DI PRESSURIZZAZIONE.
- IMPIANTI DI APPROVIGIONAMENTO IDRICO DA VASCHE DI PRIMA RACCOLTA, POZZI DA 5", POZZI ROMANI, BACINI E CORSI D'ACQUA.
- IRRIGAZIONE A PIOGGIA.

APPLICATIONS

- CIVIL AND INDUSTRIAL WATERS HANDLING PLANTS
- PRESSURISATION PLANTS.
- WATER SUPPLY FROM RAIN WATER TANKS OR RESERVOIS, 5" WELLS, ROMAN WELLS, BASINS AND WATERCOURSES.
- SPRINKLER SYSTEMS.



CARATTERISTICHE DI COSTRUZIONE:

- MOTORE A BAGNO D'OLIO (BIODEGRADABILE E DIELETTRICO) PER RAFFREDDAMENTO E LUBRIFICAZIONE CUSCINETTI.
- IMMERSIONE MASSIMA: mt. 20.
- GRADO DI PROTEZIONE IP 68.
- CLASSE DI ISOLAMENTO: B.
- TEMPERATURA MAX. LIQUIDO POMPATO: 35°C.
- VERSIONI: Monofase: 220-230V/50Hz con protettore termico incorporato e quadro elettrico in materiale plastico completo di condensatore e interruttore
- CAVO STANDARD:
Monofase: 20 metri H07RNF

SPECIALI VOLTAGGI E FREQUENZE A RICHIESTA.

DESIGN ENGINEERING:

- OIL BATH MOTOR (BIODEGRADABLE AND DIELECTRIC) FOR COOLING AND BEARING LUBRICATION.
- PERMISSIBLE DRAUGHT OF WATER: 20 m
- IP 68 PROTECTION CLASS.
- CLASS "B" INSULATION.
- MAX. PUMPED LIQUID TEMPERATURE: 35°C
- VERSIONS: Single Phase: 220-230V/50Hz with built in thermal and plastic casing power supply box comprising capacitor and switch.
- STANDARD CABLE FEATURES:
Single Phase: 20 metres H07RNF

CUSTOMISED VOLTAGE AND FREQUENCY RATING AVAILABLE ON DEMAND.

ROXY 80-120-160

Pos	Componente - Component	Materiale - Materials
1	Carcassa esterna	ACCIAIO INOX/STAINLESS STEEL A.304
2	Scudo superiore	TECNOPOLIMERO / TECHNOPOLYMER
3	Scudo porta cuscinetto	TECNOPOLIMERO / TECHNOPOLYMER
4	Portamotore	ACCIAIO INOX/STAINLESS STEEL A.304
5	Albero	ACCIAIO INOX/STAINLESS STEEL
6	O-ring	NBR
7	Flangia inferiore	OTTONE / BRASS
8	Tenuta meccanica/mechanical seal	GRAFITE ALLUMINA/GRAPHITE ALLUMINA
9	Piattello diffusore	TECNOPOLIMERO / TECHNOPOLYMER
10	Diffusore	TECNOPOLIMERO / TECHNOPOLYMER
11	Girante	TECNOPOLIMERO / TECHNOPOLYMER
12	Anello di centraggio	GHISA CON CATAFORESI/ CAST IRON WITH CATAPHORESIS
13	Griglia	ACCIAIO INOX/STAINLESS STEEL A.304



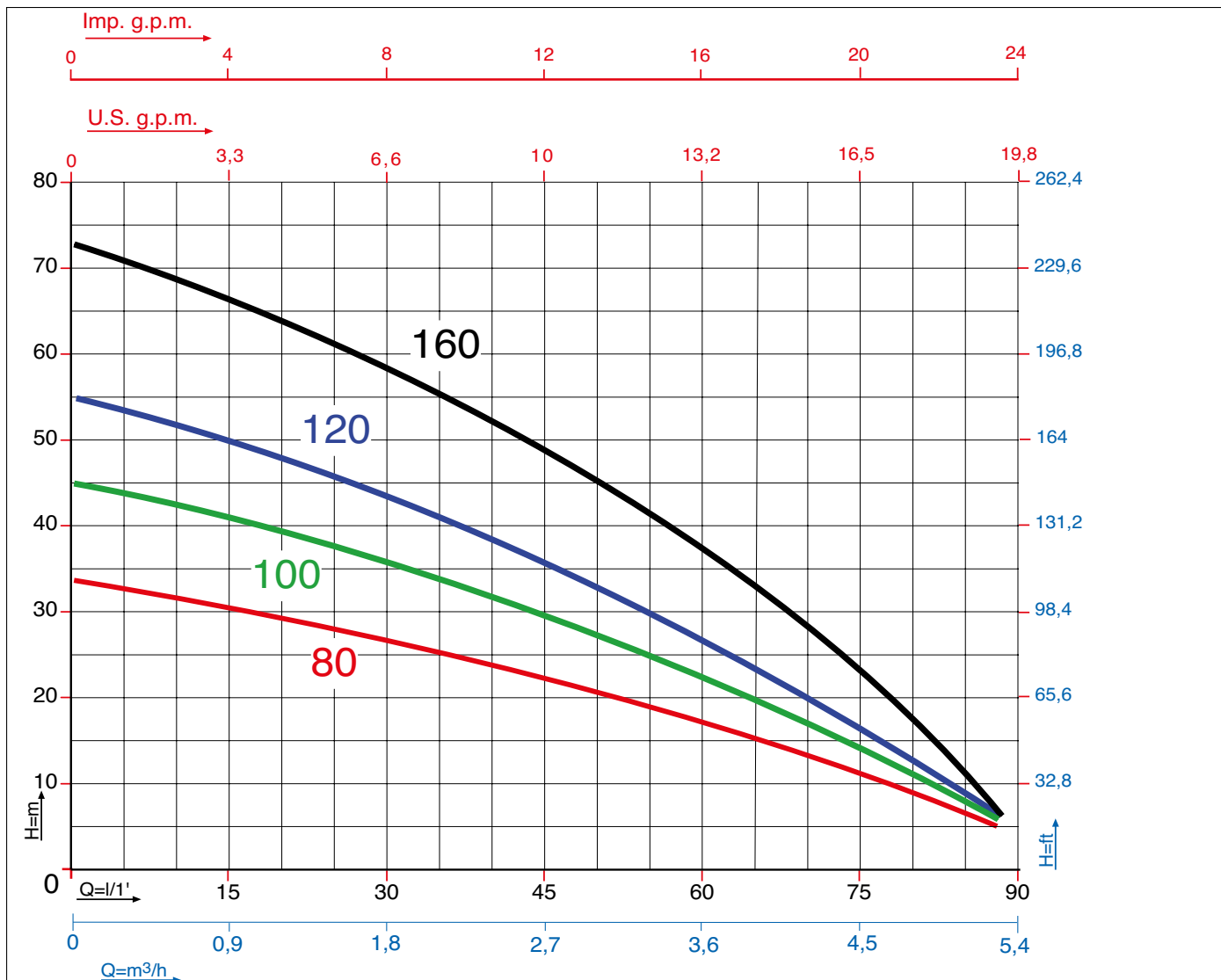

Caratteristiche di funzionamento a 2800 rpm 50Hz e 3450 rpm 60Hz - Performances at 2800 rpm 50 Hz and 3450 rpm 60 Hz
 Le prestazioni valgono per liquidi con densità $\rho = 1,0 \text{ kg/dm}^3$ ed una viscosità $\nu = 1 \text{ mm}^2/\text{s}$ / The performance data holds true for liquids with a $\rho = 1,0 \text{ kg/dm}^3$ density and a $\nu = 1 \text{ mm}^2/\text{s}$ viscosity.

MODELLO / MODEL	VOLTAGGIO VOLTAGE 50Hz	DATI ELETTRICI / ELECTRICAL DATA						DATI IDRAULICI / HYDRAULIC DATA											
		P1 max		P2 nom		I max	Condensatore Capacitor		m³/h	0	0,6	1,2	1,8	2,4	3,0	3,6	4,2	4,8	5,4
		kW	kW	HP	Ampere	µF	VC	l/min.	0	10	20	30	40	50	60	70	80	90	
ROXY 80	1 x 220-230V	1,0	0,6	0,8	4	20	450	H (m)	34	32	29	27	24	21	17	14	9	5	
ROXY 100	1x220-230V	1,2	0,75	1	5	30	450		45	42	40	35	32	27	22	18	11	5	
ROXY 120	1 x 220-230V	1,5	0,9	1,2	6	31,5	450		55	51	47	43	39	34	27	21	14	5	
ROXY 160	1 x220-230V	1,9	1,2	1,6	8	40	450		73	68	64	58	52	45	37	28	17	5	

PRELENZA TOTALE IN METRI COLONNA ACQUA
 TOTAL PUMP HEAD AND WATER COLUMN HEIGHT IN m.

DIMENSIONI e PESI / SIZE AND WEIGHT DATA:

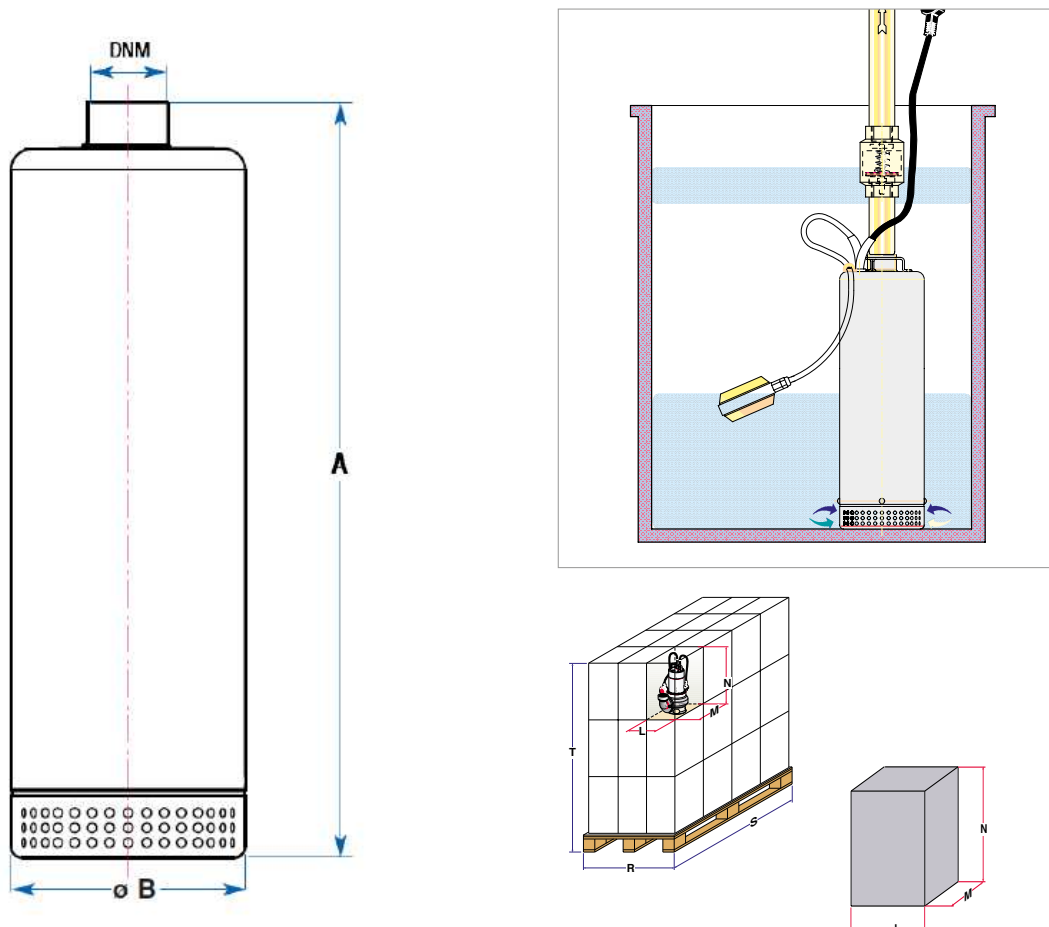

MODELLO / MODEL	DIMENSIONI in mm / PUMP DIMENSION in mm		
	DNM	A	B
ROXY 80	1" 1/4	425	127
ROXY 100	1" 1/4	460	127
ROXY 120	1" 1/4	495	127
ROXY 160	1" 1/4	560	127

MODELLO / MODEL	DIMENSIONI SCATOLA / PACKING DIMENSION				DIMENSIONI PALLET / PALLET DIMENSIONS				
	L mm	M mm	N mm	Peso/weight	R mm	S mm	T mm	nr.	Peso/weight
ROXY 80	210	650	180	11,0	800	1200	1375	35	410
ROXY 100	210	650	180	12,0	800	1200	1375	35	445
ROXY 120	210	670	240	14,0	800	1200	1375	35	515
ROXY 160	210	670	240	15,0	800	1200	1375	35	550

GPV.RX



ELETTROPOMPE SOMMERGIBILI MONOBLOCCO MULTISTADIO VERTICALI, PER POZZI DA 6" **VERTICAL SUBMERSIBLE SINGLE BLOCK MULTI STAGE ELECTRIC PUMPS, FOR 6 INCH WELLS**

PREVALENZA : 44 mt. ÷ 76,5 mt.
PORTATA : 4,5 m³/h
POTENZA NOMINALE : 0,75 kW (0,8 HP) ÷ 1,5 kW (2,0 HP)

PUMP HEAD : 44 mt ÷ 76,5 mt
DELIVERY : 4,5 m³/h
RATED HORSEPOWER : 0,75 kW (0,8 HP) ÷ 1,5 kW (2,0 HP)

APPLICAZIONI

- IMPIANTI PER LA MOVIMENTAZIONE DI ACQUE NEI SETTORI CIVILE ED INDUSTRIALE
- IMPIANTI DI PRESSURIZZAZIONE.
- IMPIANTI DI APPROVVIGIONAMENTO IDRICO DA VASCHE DI PRIMA RACCOLTA, POZZI DA 6", POZZI ROMANI, BACINI E CORSI D'ACQUA.
- IRRIGAZIONE A PIOGGIA.

APPLICATIONS

- CIVIL AND INDUSTRIAL WATERS HANDLING PLANTS
- PRESSURISATION PLANTS.
- WATER SUPPLY FROM RAIN WATER TANKS OR RESERVOIRS, 6" WELLS, ROMAN WELLS, BASINS AND WATERCOURSES.
- SPRINKLER SYSTEMS.



CARATTERISTICHE DI COSTRUZIONE:

- MOTORE A BAGNO D'OLIO (BIODEGRADABILE E DIELETTRICO) PER RAFFREDDAMENTO E LUBRIFICAZIONE CUSCINETTI.
- DOPPIA TENUTA MECCANICA: LATO MOTORE A BAGNO D'OLIO, LATO POMPA A BAGNO D'ACQUA.
- IMMERSIONE MASSIMA: mt. 20.
- GRADO DI PROTEZIONE IP 68.
- CLASSE DI ISOLAMENTO: F.
- TEMPERATURA MAX. LIQUIDO POMPATO: 35°C.
- VERSIONI: Monofase: 220-230V/50Hz con protettore termico incorporato e quadro elettrico in materiale plastico completo di condensatore e interruttore
- CAVO STANDARD:
 - Monofase: 20 metri H07RN-F per versione normale (aut.-man).
 - Trifase: 20 metri H07RN-F

SPECIALI VOLTAGGI E FREQUENZE A RICHIESTA.

DESIGN ENGINEERING:

- OIL BATH MOTOR (BIODEGRADABLE AND DIELECTRIC) FOR COOLING AND BEARING LUBRICATION.
- DOUBLE MECHANICAL SEALS: ENGINE FACE: OIL BATH. PUMP FACE: WATER BATH.
- PERMISSIBLE DRAUGHT OF WATER: 20 m
- IP 68 PROTECTION CLASS.
- CLASS "F" INSULATION.
- MAX. PUMPED LIQUID TEMPERATURE: 35°C
- VERSIONS: Single Phase: 220-230V/50Hz with built in thermal and plastic casing power supply box comprising capacitor and switch.
- STANDARD CABLE FEATURES:
 - Single Phase: 20 metres H07RN-F for the standard version (automatic-manual).
 - Three Phase: 20 metres H07RN-F

CUSTOMISED VOLTAGE AND FREQUENCY RATING AVAILABLE ON DEMAND.

TABELLA MATERIALI / MATERIALS TABLE:

Pos.	Componente -Component	Materiale - Materials
A	Carcassa esterna / External motor housing	ACCIAIO INOX AISI 304 - DIN 1.4301 / STAINLESS STEEL
B	Giranti / Impellers	ACCIAIO INOX AISI 303 - DIN 1.4005 / STAINLESS STEEL
C	Albero (lato pompa) / Shaft (pump side)	ACCIAIO INOX AISI 304 - DIN 1.4301 / STAINLESS STEEL
D	Tenuta meccanica GPV.RX / Mechanical seal	CARBURO DI SILICIO / SILICON CARBIDE
	Lato motore / Motor face	
	Lato pompa / Pump face	
E	O-ring	NBR
H	Carcassa motore / Motor housing	ACCIAIO INOX AISI 304 - DIN 1.4301 / STAINLESS STEEL
I	Coperchio / Cover	OTTONE / BRASS
L	Diffusori + piattelli / Diffusers + disks	ACCIAIO INOX AISI 304 - DIN 1.4301 / STAINLESS STEEL
N	Base d'aspirazione / Suction base	OTTONE / BRASS
R	Flangia inferiore / Lower support	OTTONE / BRASS
S	Flangia superiore / Upper support	
V	Convogliatore / Conveyor	

GPV.RX 100 - 150 - 200

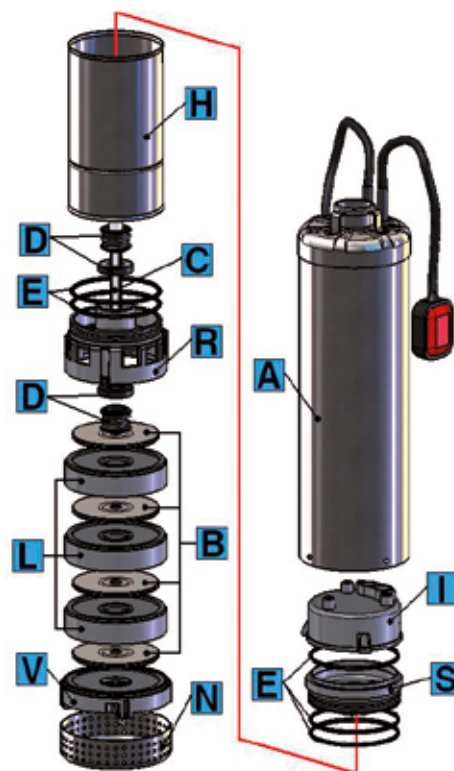

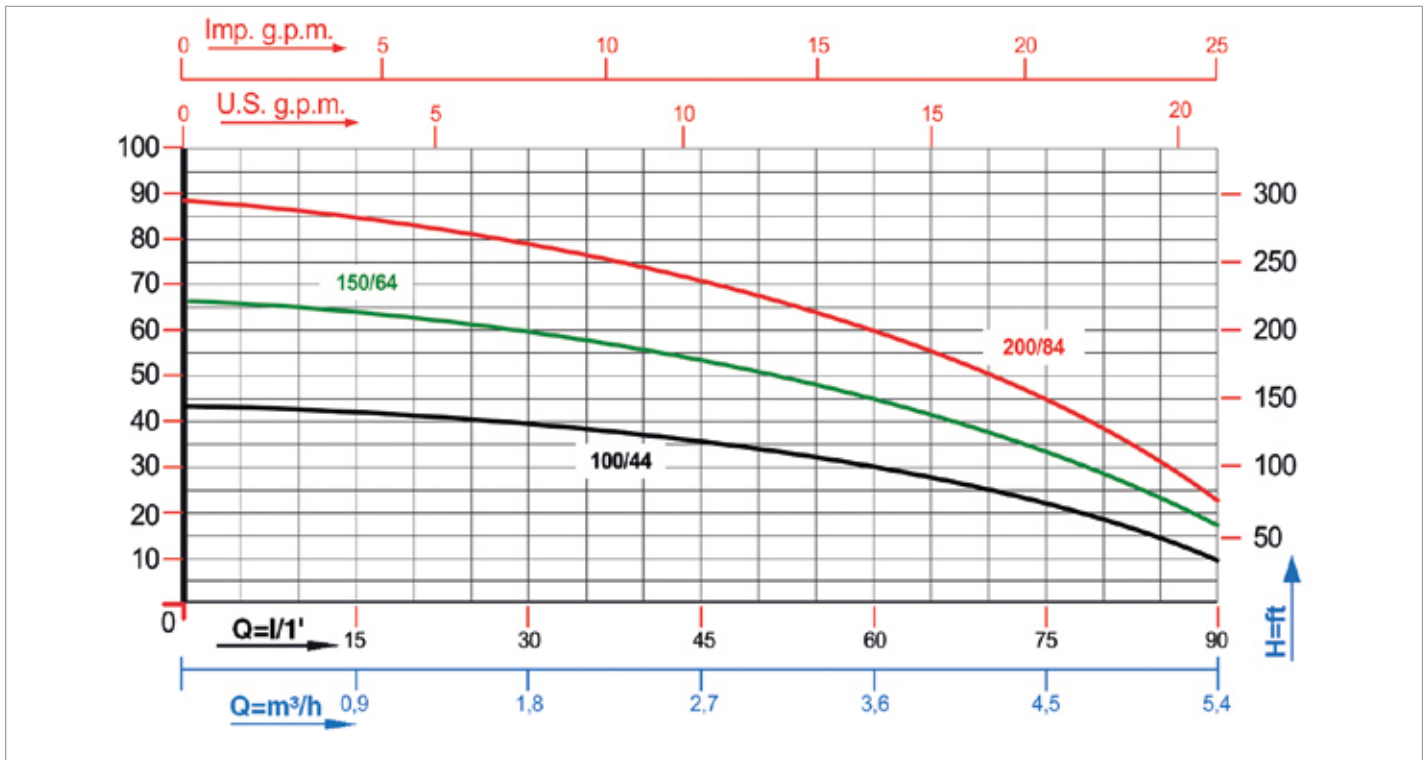

Caratteristiche di funzionamento a 2800 rpm 50Hz e 3450 rpm 60Hz - Performances at 2800 rpm 50 Hz and 3450 rpm 60 Hz
 Le prestazioni valgono per liquidi con densità $p = 1,0 \text{ kg/dm}^3$ ed una viscosità $v = 1 \text{ mm}^2/\text{s}$ / The performance data holds true for liquids with a $p = 1,0 \text{ kg/dm}^3$ density and a $v = 1 \text{ mm}^2/\text{s}$ viscosity.

MODELLO MODEL	VOLTAGGIO VOLTAGE 50 Hz	DATI ELETTRICI / ELECTRICAL DATA						DATI IDRAULICI / HYDRAULIC DATA									
		P1max	P2 nom.	I max	Condensatore Capacitor		m³/h	0	0,6	1,2	1,8	2,4	3	3,6	4,5	9,6	
		kW	kW	HP	Ampere	µF	VC	l/min.	0	10	20	30	40	50	60	75	100
GPV.RX 100/44 M	1 x 220-230V	0,9	0,75	1,0	4,0	20,0	450	H (m)	44,0	44,5	41,5	38,5	35,0	29,5	25,0	16,0	---
GPV.RX 150/64 M	1 x 220-230V	1,1	1,1	1,5	5,0	20,0	450		53,0	51,5	50,0	46,5	42,0	35,0	30,0	19,0	---
GPV.RX 200/84 M	1 x 220-230V	1,4	1,5	2,0	6,5	30,0	450		76,5	74,0	70,0	65,0	60,0	54,0	46,0	32,5	---

PREVALENZA TOTALE in METRI COLONNA ACQUA / TOTAL PUMP HEAD AND WATER COLUMN HEIGHT IN m.

DIMENSIONI e PESI / SIZE AND WEIGHT DATA:

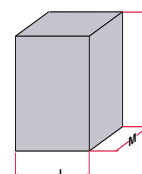
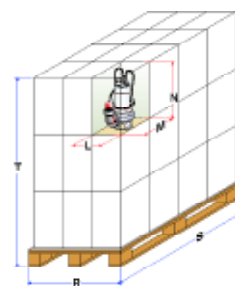
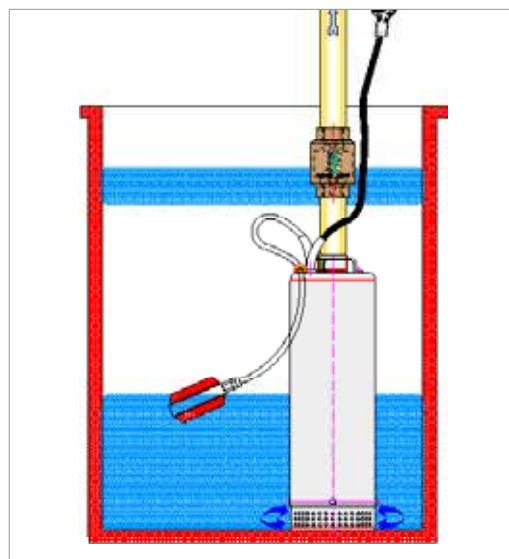
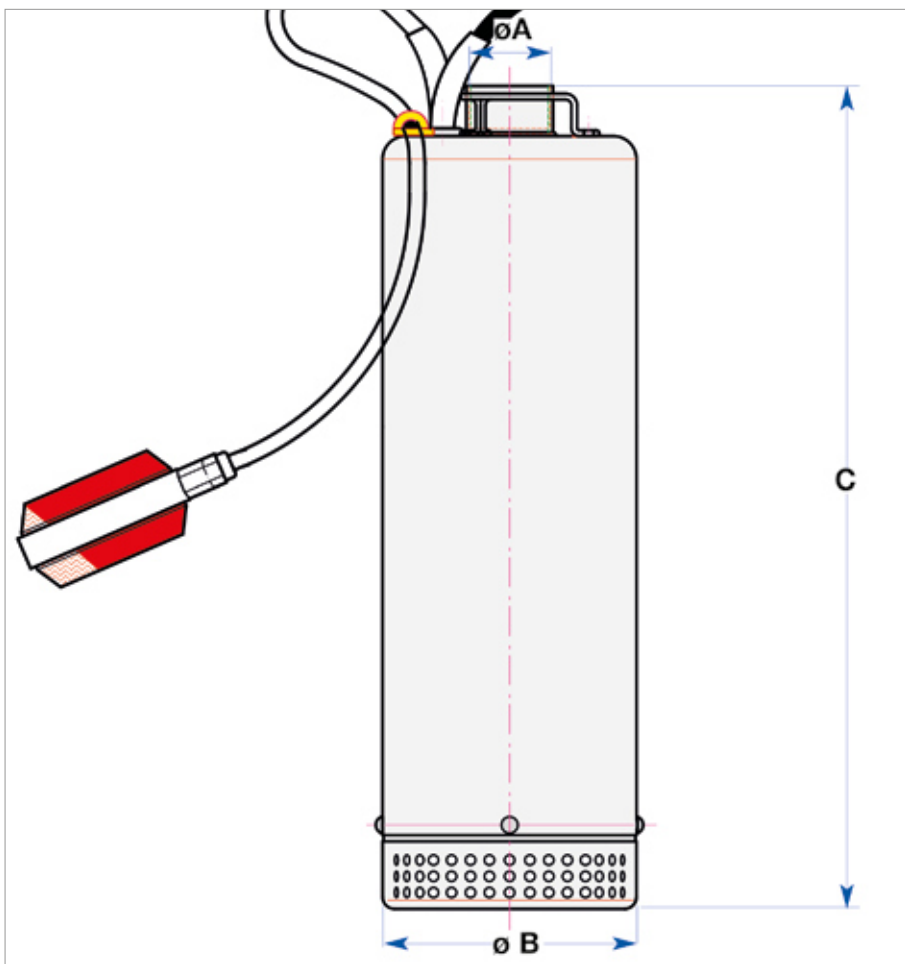

MODELLO / MODEL	DIMENSIONI POMPA in mm. / PUMP DIMENSIONS in mm.		
	A	B	C
GPV.RX 100/44 M	1" 1/4	130	434
GPV.RX 150/64 M	1" 1/4	130	458
GPV.RX 200/84 M	1" 1/4	130	530

MODELLO MODEL	DIMENSIONI SCATOLA / PACKING DIMENSIONS				DIMENSIONI PALLET / PALLET DIMENSIONS				
	L mm	M mm	N mm	Peso / Weight Kg	R mm	S mm	T mm	nr. scatole/cartons	Peso / Weight Kg
GPV.RX 100/44	455	210	250	14,6	800	1200	1500	30	465
GPV.RX 150/64	490	210	250	16,5	800	1200	1500	30	520
GPV.RX 200/84	585	210	250	18,8	800	1200	1500	30	590

WORKER 250 - 350



ELETTROPOMPE SOMMERGIBILI MULTISTADIO VERTICALI PER POZZI DA 8 E 10 POLLICI VERTICAL SUBMERSIBLE MULTI STAGE ELECTRI PUMPS FOR 8 AND 10 INCH WELLS

PREVALENZA : 35,0 mt. ÷ 45,0 mt.
PORTATA : 18 m³/h
POTENZA NOMINALE : 1,1 kW (1,5HP) ÷ 1,8 kW (2,5HP)

PUMP HEAD : 35,0 mt ÷ 45,0 mt
DELIVERY : 18,0 m³/h
RATED HORSEPOWER : 1,1 kW (1,5HP) ÷ 1,8 kW (2,5HP)

APPLICAZIONI

- PARTICOLARMENTE INDICATE NEL SETTORE AGRICOLO PER IRRIGAZIONE, POMPAGGIO DI ACQUA DA VASCHE O SERBATOI DI PRIMA RACCOLTA, POZZI DA 8 A 10 POLLICI POCO PROFONDI 10-20 MT, BACINI E CORSI D'ACQUA.
- MOVIMENTAZIONE NEL SETTORE INDUSTRIALE DI ACQUE DI RAFFREDDAMENTO E DI ALIMENTAZIONE E SCARICO.
- PRESSURIZZAZIONE CON POMPA INSERITA NEL SERBATOIO O POZZO

APPLICATIONS

- PARTICULARLY SUITED TO THE AGRICULTURAL AND FARMING SECTORS FOR IRRIGATION PURPOSES, FOR CATCH TANK AND RESERVOIR CATCH-WATER PUMP OUT, FROM 8 TO 10 INCH WELL, WITH 10-20 MT DEEP, WATER BASIN AND WATER DRAIN FLOW PUMP OUT.
- FOR INDUSTRIAL COOLING, FEED-IN AND DISCHARGE WATER HANDLING.
- FOR PRESSURISATION, WITH TANK OR WELL PUMP INCLUSION.



CARATTERISTICHE DI COSTRUZIONE:

- MOTORE A BAGNO D'OLIO (BIODEGRADABILE E DIELETTRICO) PER RAFFREDDAMENTO E LUBRIFICAZIONE CUSCINETTI.
 - DOPPIA TENUTA MECCANICA: LATO MOTORE A BAGNO D'OLIO. LATO POMPA A BAGNO D'ACQUA.
 - IMMERSIONE MASSIMA: 20 mt
 - GRADO DI PROTEZIONE IP 68.
 - CLASSE DI ISOLAMENTO: F.
 - TEMPERATURA MAX. LIQUIDO POMPATO: 35°C .
 - PASSAGGIO LIBERO: PULITO.
 - MONOFASE 220 - 277V/50Hz o 220 – 277V / 60 Hz :
 - con protettore termico incorporato e condensatore permanentemente inserito. (HP 1,5)
 - con protettore termico incorporato e quadro elettrico in materiale plastico completo di condensatore e interruttore. (HP 2,5)
 - TRIFASE 220-277V/60Hz o 380-480V/60Hz con protezione da sovraccarico a cura dell'utente.
 - CAVO STANDARD:
 - Monofase: 10 metri H07RN-F senza spina.
10 metri H07RN-F completa di quadro elettrico con spezzone cavo 0,7 metri senza spina.
 - Trifase: 10 metri H07RN-F senza spina.
- SPECIALI VOLTAGGI E FREQUENZE A RICHIESTA.

ACCESSORI DISPONIBILI A RICHIESTA:

- QUADRO ELETTRICO TRIFASE DI PROTEZIONE E COMANDO AUTOMATICO A MEZZO DI GALLEGGIANTE ELETTROMECCANICO.
- GALLEGGIANTE 10-20 mt. DI CAVO.
- RACCORDI E PORTA GOMMA RAPIDI DA 2" e 3" IN ALLUMINIO RAPIDO.

DESIGN ENGINEERING:

- OIL BATH MOTOR (BIODEGRADABLE AND DIELECTRIC OIL) FOR COOLING AND BEARING LUBRICATION.
 - DOUBLE MECHANICAL SEALS: ENGINE FACE: OIL BATH. PUMP FACE: WATER BATH.
 - PERMISSIBLE DRAUGHT OF WATER: 20 mt
 - IP 68 PROTECTION CLASS.
 - CLASS "F" INSULATION.
 - MAX. PUMPED LIQUID TEMPERATURE: 35°C
 - BY PASS SECTION: CLEAN
 - SINGLE PHASE 220 - 277V/50Hz or 220 – 277V / 60 Hz:
 - with built in thermal protection and permanent capacitor. (HP 1,5)
 - with built in thermal protection and plastic casing power supply box comprising capacitor and switch. (HP 2,5)
 - THREE PHASE 220-277V/60 Hz or 380-480V/60Hz with overload protection care of the User.
 - STANDARD CABLE FEATURES:
 - Single Phase: 10 metres H07RN-F without plug.
10 metres H07RN-F complete with power supply box 0.7 m cable section, without connection plug.
 - Three phase: 10 metres H07RN-F without plug.
- CUSTOMISED VOLTAGE AND FREQUENCY RATING AVAILABLE ON DEMAND.

ACCESSORIES AVAILABLE ON DEMAND:

- THREE PHASE ELECTRICAL SAFETY POWER SUPPLY BOX WITH AUTOMATIC ELECTROMECHANICAL FLOATER CONTROLS.
- FLOATER CONTROLS 10-20 mt. ELECTRIC CABLE.
- CONNECTION PIECES FROM 3" CONNECTING NOZZLE IN ALUMINIUM.

TABELLA MATERIALI / MATERIALS TABLE:

Pos.	Componente / Component	Materiale / Materials	
A	Carcassa esterna <i>External housing</i>	ACCIAIO INOX AISI 304 - DIN 1.4301 STAINLESS STEEL	
B	Girante / <i>Impeller</i>		
C	Albero (lato pompa) / <i>Shaft (pump side)</i>	ACCIAIO INOX AISI 316 - DIN 1.4401 / STAINLESS STEEL	
D	Doppia tenuta meccanica <i>Double mechanical seal</i>	Lato pompa / <i>Pump face</i>	CARBURO DI SILICIO-CERAMICA SILICON CARBIDE-CERAMIC
		Lato motore / <i>Motor face</i>	GRAFITE-CERAMICA CARBIDE-CERAMIC
E	O-ring	NBR	
H	Carcassa motore / <i>Motor housing</i>	ACCIAIO INOX AISI 304 - DIN 1.4301 / STAINLESS STEEL	
I	Coperchio / <i>Cover</i>		
L	Diffusore / <i>Diffuser</i>	GHISA (G20) CAST IRON	
M	Griglia / <i>Grid</i>	ACCIAIO INOX AISI 304 - DIN 1.4301 / STAINLESS STEEL	
R	Flangia inferiore / <i>Lower flange</i>	ALLUMINIO CON TRATTAMENTO SPECIALE ALUMINIUM WITH SPECIAL TREATMENT	
Y	Piattello / <i>Disk base</i>	ACCIAIO / STEEL	

WORKER 250 - 350

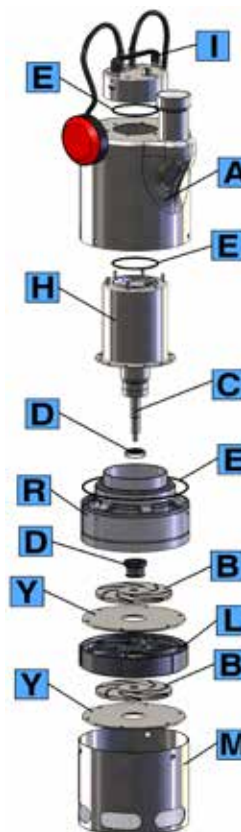

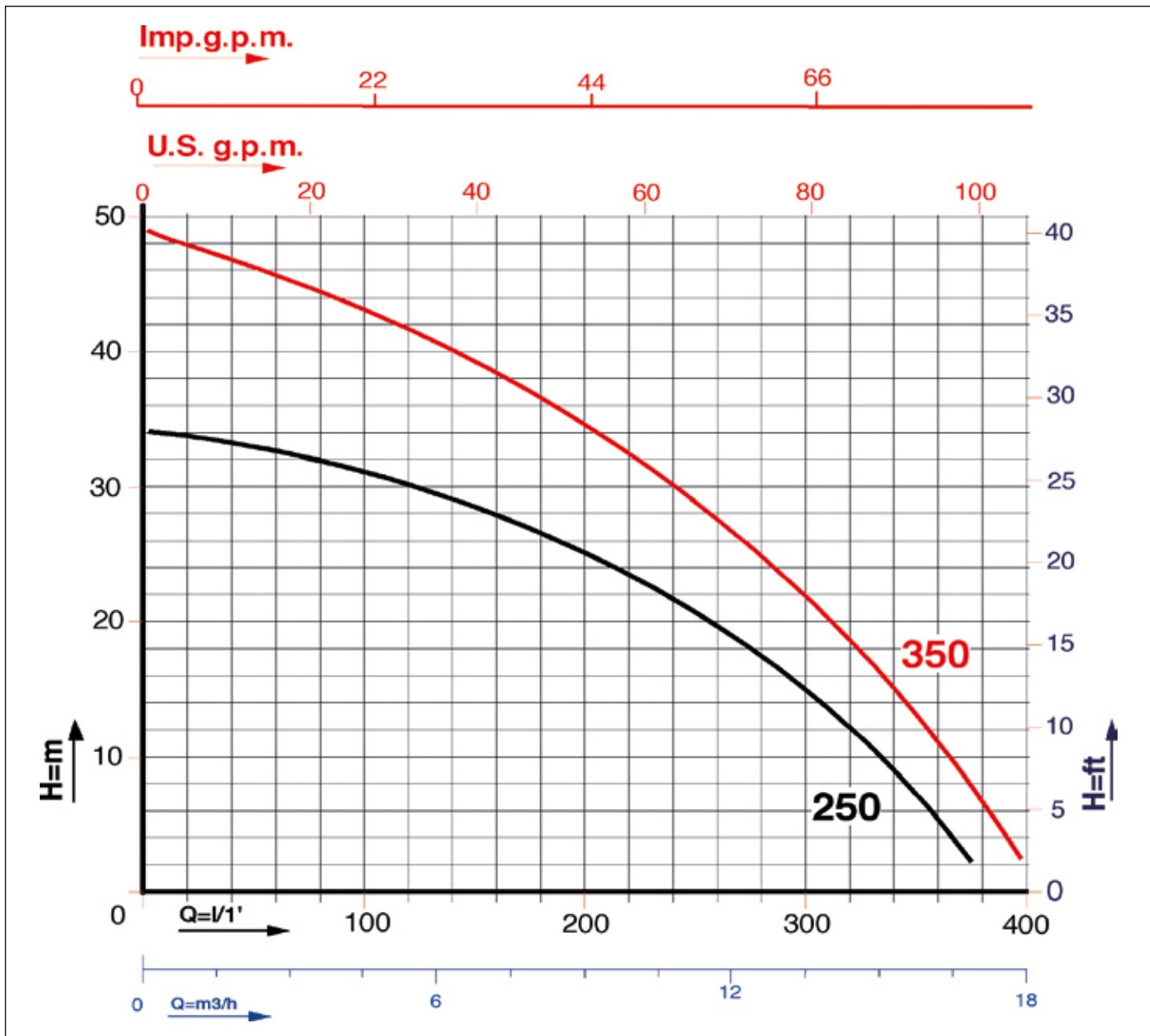

Caratteristiche di funzionamento a 3450 rpm 60Hz - Performances at 3450 rpm 60 Hz

Le prestazioni valgono per liquidi con densità $\rho = 1,0 \text{ kg/dm}^3$ ed una viscosità $\nu = 1 \text{ mm}^2/\text{s}$ / The performance data holds true for liquids with a $\rho = 1,0 \text{ kg/dm}^3$ density and a $\nu = 1 \text{ mm}^2/\text{s}$ viscosity.

MODELLO MODEL	VOLTAGGIO VOLTAGE	DATI ELETTRICI / ELECTRICAL DATA						DATI IDRAULICI / HYDRAULIC DATA							
		P1max kW	P2 nom. kW	I max HP	I max Ampere	Condensatore Capacitor μF	VC	m³/h	0	3	6	9	12	15	18
WORKER 250 M	1 x 220-230V	2,9	1,8	2,5	13	30	450	H (m)	34,0	32,0	29,0	25,0	19,0	10,0	2,0
WORKER 250 T	3 x 380-400V	2,7	1,8	2,5	4,6	---	---		34,0	32,0	29,0	25,0	19,0	10,0	2,0
WORKER 350 M	1 x 220-230V	4,5	2,6	3,5	19,5	40	450		49,0	45,5	41,0	34,0	27,0	17,0	2,0
WORKER 350 T	3 x 380-400V	4,3	2,6	3,5	6,5	---	---		49,0	45,5	41,0	34,0	27,0	17,0	2,0

PREVALENZA TOTALE IN METRI COLONNA ALZATA
TOTAL PUMP HEAD AND WATER COLUMN HEIGHT IN m.

DIMENSIONI E PESI / SIZE AND WEIGHT DATA:

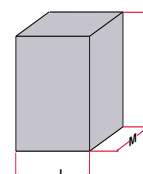
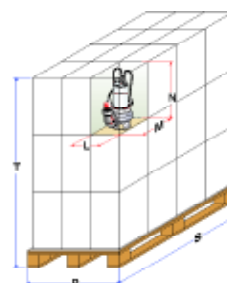
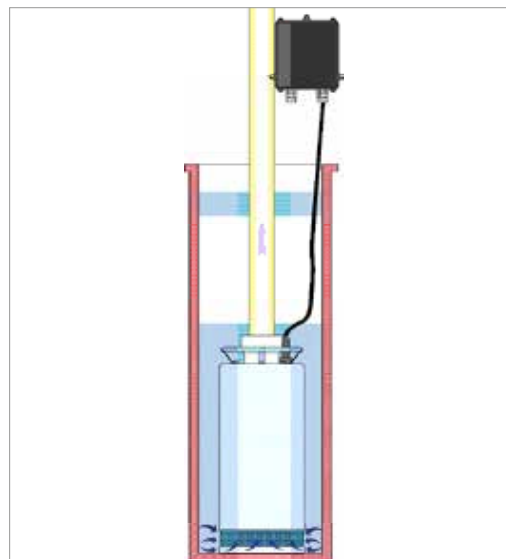
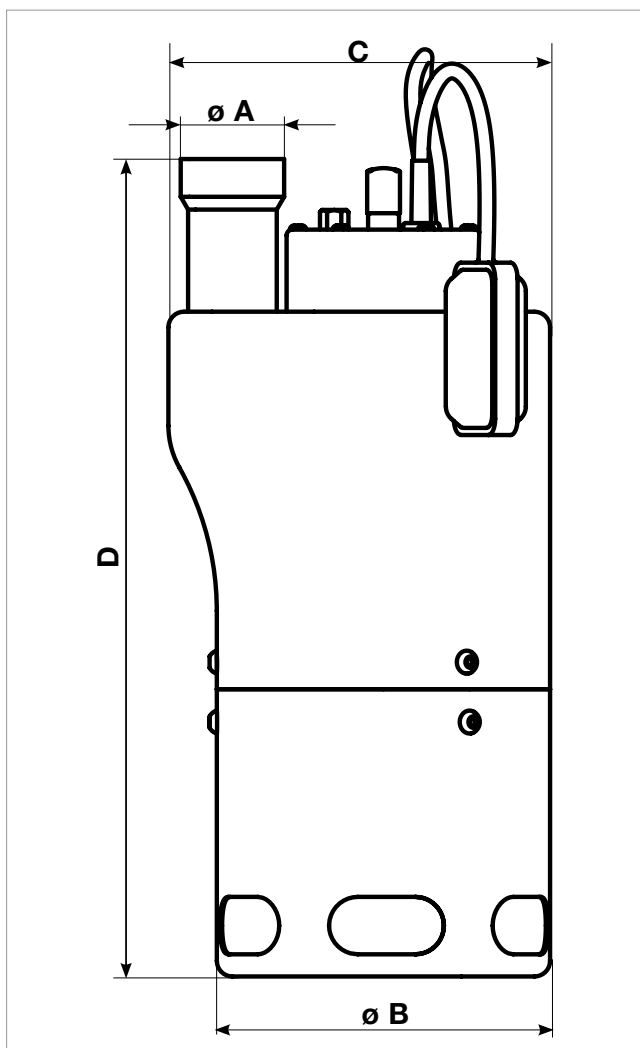

MODELLO / MODEL	DIMENSIONI POMPA in mm. / PUMP DIMENSIONS in mm.			
	ABCD			
WORKER 250 M	2"	203	230	490
WORKER 250 T	2"	203	230	490
WORKER 350 M	2"	203	230	490
WORKER 350 T	2"	203	230	490

MODELLO / MODEL	DIMENSIONI SCATOLA / PACKING DIMENSIONS				DIMENSIONI PALLET / PALLET DIMENSIONS				
	LMN			Peso / Weight	RST			nr.	Peso / Weight
	mm.	mm.	mm.	Kg.	mm.	mm.	mm.	scatolecartons	Kg.
WORKER 250 M	650	260	370	33,0	800	1200	2350	24	817
WORKER 250 T	650	260	370	33,0	800	1200	2350	24	817
WORKER 350 M	650	260	370	35,0	800	1200	2350	24	865
WORKER 350 T	650	260	370	35,0	800	1200	2350	24	865

WORKER



ELETTROPOMPE SOMMERSIBILI MONOBLOCCO MULTISTADIO VERTICAL PER POZZI DA 8 e 10 POLLICI **VERTICAL SUBMERSIBLE MULTI STAGE ELECTRIC PUMPS FOR 8 AND 10 INCH WELLS**

PREVALENZA : 42 mt. ÷ 91 mt.
PORTATA : 21 m³/h ÷ 30 m³/h
POTENZA NOMINALE : 2,2 kW (3HP) ÷ 7,5 kW (10HP)

PUMP HEAD : 42,0 mt ÷ 91,0 mt
DELIVERY : 21,0 m³/h ÷ 30,0 m³/h
RATED HORSEPOWER : 2,2 kW (1,5HP) ÷ 7,5 kW (10,0HP)

APPLICAZIONI

- PARTICOLARMENTE INDICATE NEL SETTORE AGRICOLO PER IRRIGAZIONE, POMPAGGIO DI ACQUA DA VASCHE O SERBATOI DI PRIMA RACCOLTA, POZZI DA 8 A 10 POLLICI POCO PROFONDI 10-20 MT, BACINI E CORSI D'ACQUA.
- MOVIMENTAZIONE NEL SETTORE INDUSTRIALE DI ACQUE DI RAFFREDDAMENTO E DI ALIMENTAZIONE E SCARICO.
- PRESSURIZZAZIONE CON POMPA INSERITA NEL SERBATOIO O POZZO.
- FONTANE.

APPLICATIONS

- PARTICULARLY SUITED TO THE AGRICULTURAL AND FARMING SECTORS FOR IRRIGATION PURPOSES, FOR CATCH TANK AND RESERVOIR CATCH-WATER PUMP OUT, FROM 8 TO 10 INCH WELL, WITH 10-20 MT DEEP, WATER BASIN AND WATER DRAIN FLOW PUMP OUT.
- FOR INDUSTRIAL COOLING, FEED-IN AND DISCHARGE WATER HANDLING.
- FOR PRESSURISATION, WITH TANK OR WELL PUMP INCLUSION.
- FOR FOUNTAINS.



ARVEN[®]
WATER PUMPS

CARATTERISTICHE DI COSTRUZIONE:

- MOTORE A BAGNO D'OLIO (BIODEGRADABILE E DIELETTRICO) PER RAFFREDDAMENTO E LUBRIFICAZIONE CUSCINETTI.
- DOPPIA TENUTA MECCANICA: LATO MOTORE A BAGNO D'OLIO. LATO POMPA A BAGNO D'ACQUA.
- IMMERSIONE MASSIMA: mt. 20 .
- GRADO DI PROTEZIONE IP 68 .
- CLASSE DI ISOLAMENTO: F
- TEMPERATURA MAX. LIQUIDO POMPATO: 35°C
- VERSIONI:
Trifase: 220-277V/ 50Hz o 380 – 480V / 50Hz e 220-277V/ 60Hz o 380 – 480V /60Hz con protezione da sovraccarico a cura dell'utente
- POTENZA MOTORE: DA 3 Hp a 10 Hp SOLO VERSIONI TRIFASE.
- CAVO STANDARD:
Trifase: 10 metri H07RN-F senza spina

SPECIALI VOLTAGGI E FREQUENZE A RICHIESTA.

ACCESSORI DISPONIBILI A RICHIESTA:

- QUADRO ELETTRICO TRIFASE DI PROTEZIONE E COMANDO AUTOMATI CO A MEZZO DI GALLEGGIANTE ELETTROMECCANICO.
- GALLEGGIANTE 10-20 mt. DI CAVO.
- RACCORDI E PORTAGOMMA DA 3" IN ALLUMINIO

DESIGN ENGINEERING:

- OIL BATH MOTOR (BIODEGRADABLE AND DIELECTRIC) FOR COOLING AND BEARING LUBRICATION.
- DOUBLE MECHANICAL SEALS: ENGINE FACE: OIL BATH. PUMP FACE: WATER BATH.
- PERMISSIBLE DRAUGHT OF WATER: 20 m
- IP 68 PROTECTION CLASS.
- CLASS "F" INSULATION.
- MAX. PUMPED LIQUID TEMPERATURE: 35°C
- VERSIONS:
Three Phase: 220-277V/ 50Hz or 380 – 480V / 50Hz and 220-277V/ 60Hz or 380 – 480V /60Hz with overload protection care of the User.
- MOTOR POWER: From 3 HP to 10 HP Only three phase versions.
- STANDARD CABLE FEATURES:
Three Phase: 10 metres H07RN-F without plug

CUSTOMISED VOLTAGE AND FREQUENCY RATING AVAILABLE ON DEMAND.

ACCESSORIES AVAILABLE ON DEMAND:

- THREE PHASE ELECTRICAL SAFETY POWER SUPPLY BOX WITH AUTO Matic ELECTROMECHANICAL FLOATER CONTROLS.
- FLOATER CONTROLS 10-20 mt. ELECTRIC CABLE.
- CONNECTION PIECES FROM 3" CONNECTING NOZZLE IN ALUMINIUM.

TABELLA MATERIALI / MATERIALS TABLE:

Pos.	Componente / Component	Materiale / Materials
A	Carcassa esterna con calotta e maniglie <i>External housing with cap and handles</i>	ACCIAIO INOX AISI 304 DIN 1.4301 STAINLESS STEEL
B	Girante / <i>Impeller</i>	
C	Albero (lato pompa) / <i>Shaft (pump side)</i>	ACCIAIO INOX AISI 316 DIN 1.4401 / STAINLESS STEEL
D	Tenuta meccanica <i>Mechanical seal</i>	Lato pompa / <i>Pump side</i> CARBURO DI SILICIO- CARBURO DI SILICIO / SILICON CARBIDE-SILICON CARBIDE
		Lato motore / <i>Motor side</i> GRAFITE CERAMICA CARBIDE CERAMIC
E	O-ring	NBR
H	Carcassa motore / <i>Motor housing</i>	ACCIAIO INOX AISI 304 DIN 1.4301 / STAINLESS STEEL
I	Coperchio / <i>Cover</i>	GHISA (G20) CAST IRON
L	Diffusore / <i>Diffuser</i>	
M	Griglia / <i>Greed</i>	ACCIAIO INOX AISI 304 DIN 1.4301 / STAINLESS STEEL
O	Distanziale / <i>Sleeve</i>	
R	Flangia inferiore / <i>Upper flange</i>	GHISA (G20) CAST IRON
S	Flangia superiore / <i>Upper flange</i>	
K	Guarnizione / <i>Gasket</i>	NBR
V	Convogliatore / <i>Conveyor</i>	GHISA (G20) CAST IRON
Y	Piattello / <i>Disk base</i>	ACCIAIO / STEEL

WORKER 300-400-500-750-1000

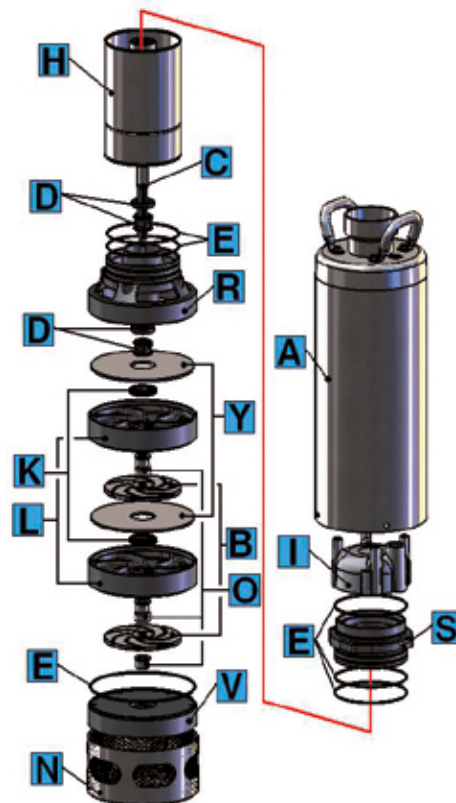

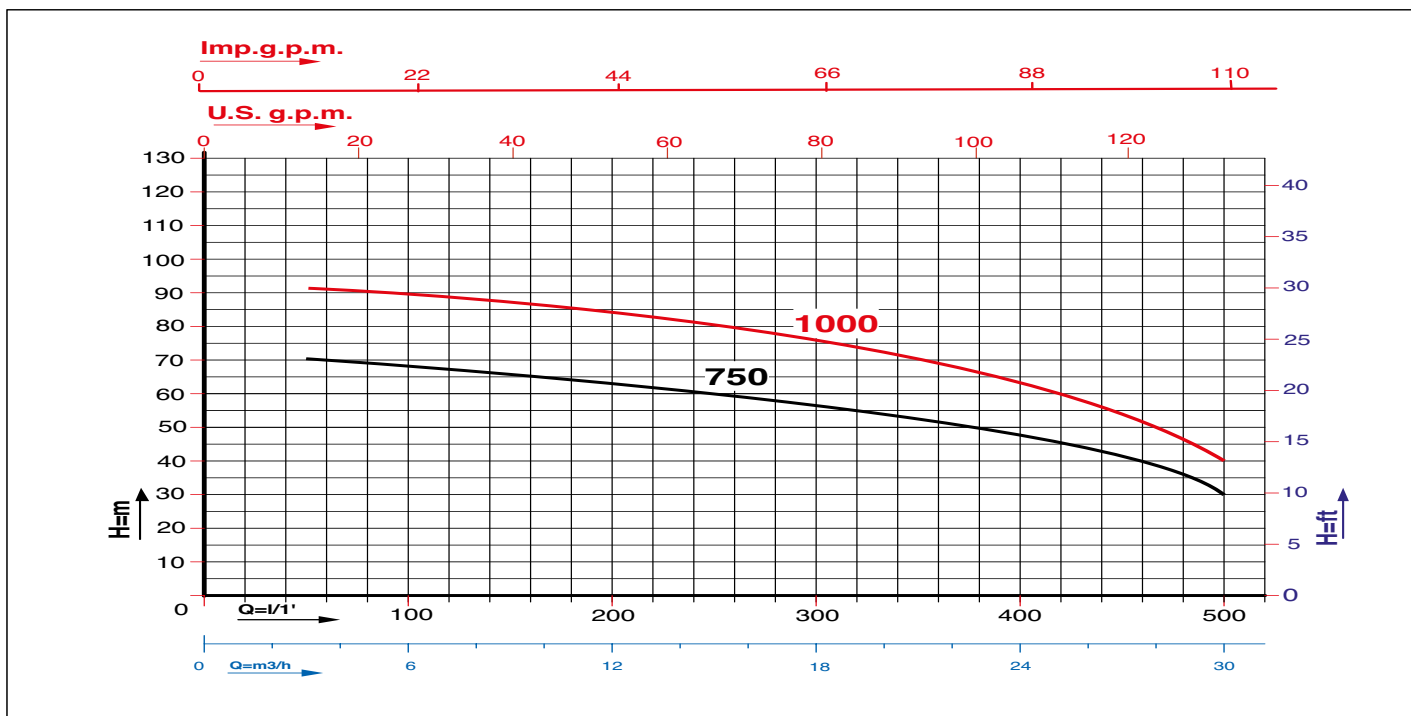
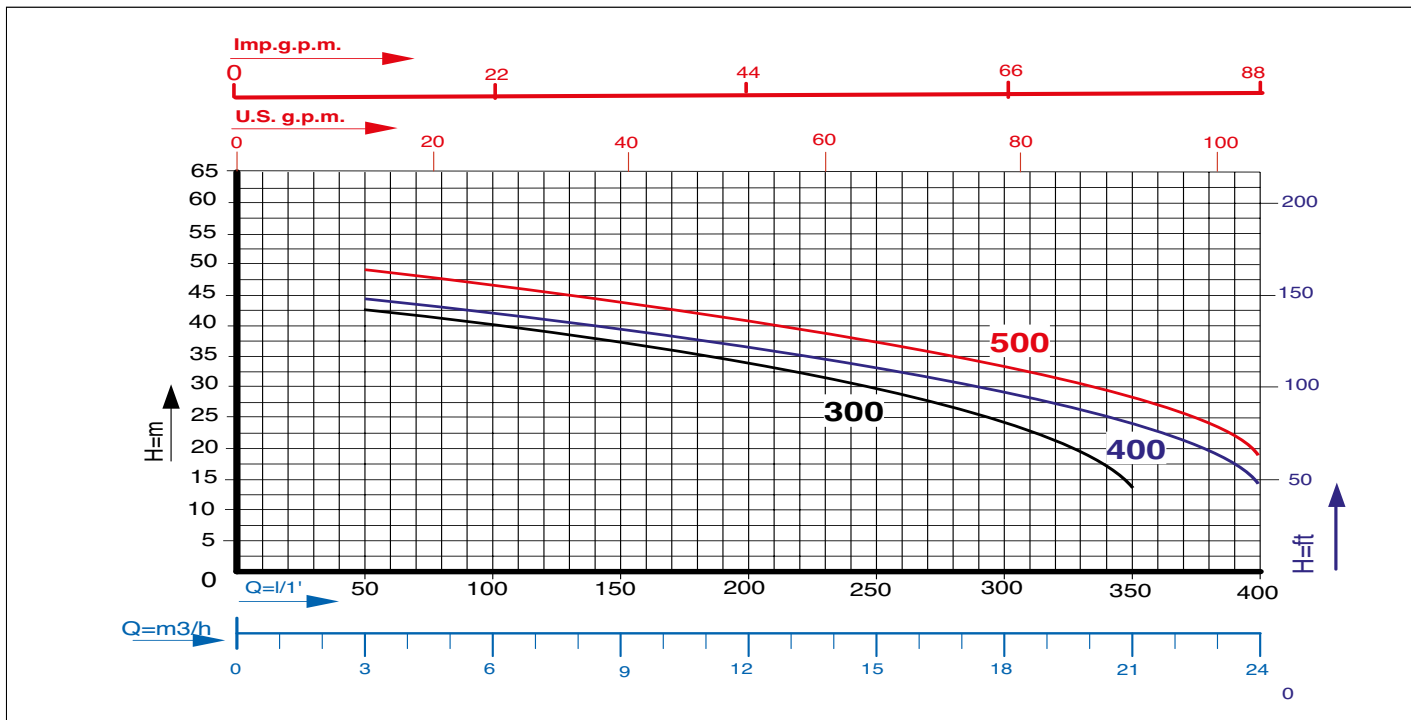

Caratteristiche di funzionamento a 2800 rpm 50Hz e 3450 rpm 60Hz - Performances at 2800 rpm 50 Hz and 3450 rpm 60 Hz
 Le prestazioni valgono per liquidi con densità $\rho = 1,0 \text{ kg/dm}^3$ ed una viscosità $\nu = 1 \text{ mm}^2/\text{s}$ / The performance data holds true for liquids with a $\rho = 1,0 \text{ kg/dm}^3$ density and a $\nu = 1 \text{ mm}^2/\text{s}$ viscosity.

MODELLO MODEL	VOLTAGGIO VOLTAGE	DATI ELETTRICI / ELECTRICAL DATA						DATI IDRAULICI / HYDRAULIC DATA (2850 min ⁻¹)											
		P1 max kW	P2 nom. kW	I max HP	I max Ampere	Condensatore Capacitor µF VC		m³/h	3	6	9	12	15	21	24	27	30		
WORKER 300 T	3 x 380-400V	3,0	2,2	3,0	6,0	---	---	H (m)	42,0	40,0	37,0	33,0	28,0	13,0					
WORKER 400 T	3 x 380-400V	3,9	3,0	4,0	6,6	---	---		44,0	42,0	38,0	36,0	32,0	22,0	14,0				
WORKER 500 T	3 x 380-400V	4,9	3,7	5,0	9,8	---	---		49,0	47,0	43,0	41,0	37,0	27,0	18,0				
WORKER 750 T	3 x 380-400V	7,3	5,5	7,5	12,6	---	---		70,0	68,0	65,0	63,0	60,0	52,0	48,0	40,0	30,0		
WORKER 1000 T	3 x 380-400V	10,1	7,5	10,0	15,6	---	---		91,0	90,0	86,0	84,0	80,0	69,0	64,0	53,0	40,0		

PRESSIONE TOTALE IN METRI COLONNA ACQUA / TOTAL PUMP HEAD AND WATER COLUMN HEIGHT IN Mtr.

DIMENSIONI e PESI / SIZE AND WEIGHT DATA:

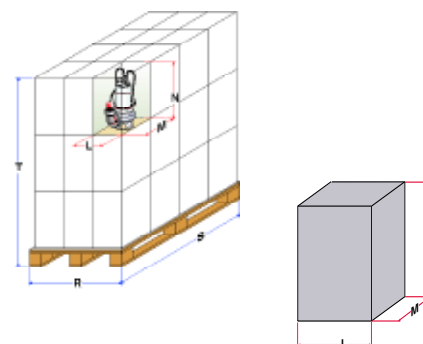
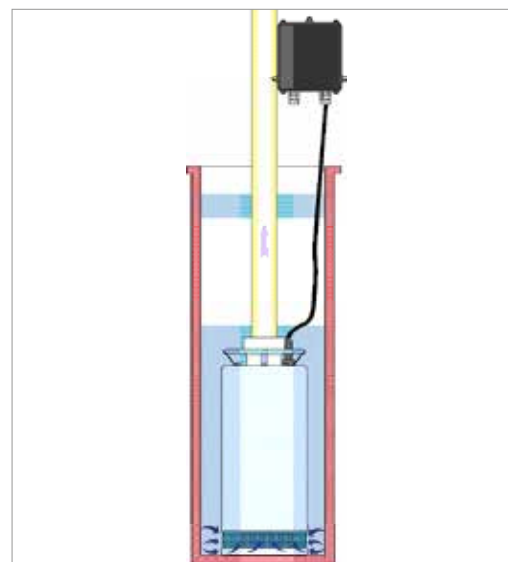
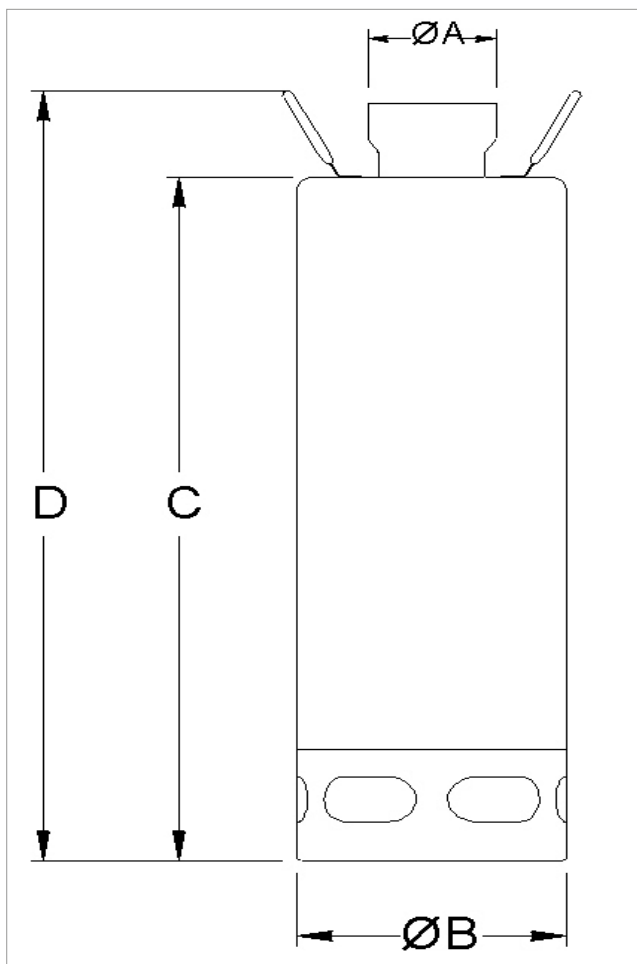

MODELLO / MODEL	DIMENSIONI POMPA in mm. / PUMP DIMENSIONS in mm.			
	A	B	C	D
WORKER 300 T	3"	204	584	651
WORKER 400 T	3"	204	584	651
WORKER 500 T	3"	204	584	651
WORKER 750 T	3"	204	584	651
WORKER 1000 T	3"	204	584	651

MODELLO / MODEL	DIMENSIONI SCATOLA / PACKING DIMENSIONS				DIMENSIONI PALLET / PALLET DIMENSIONS				
	L	M	N	Peso / Weight Kg.	R	S	T	nr.	Peso / Weight Kg.
	mm.	mm.	mm.		mm.	mm.	mm.	scatole/cartons	
WORKER 300 T	720	400	260	38	800	1200	900	25	955
WORKER 400 T	720	400	260	43	800	1200	900	25	1080
WORKER 500 T	720	400	260	48	800	1200	900	25	1205
WORKER 750 T	900	400	260	57	800	1200	900	18	1031
WORKER 1000 T	900	400	260	68	800	1200	900	18	1229

SISTEMI DI DISCESA (DN 50) PER IMPIANTI FISSI
DOWN STROKE GUIDE RAIL SYSTEM (DN 50)
FOR FIXED PLANTS

MODELLO / MODEL	DIMENSIONI POMPA in mm. PUMP DIMENSIONS in mm.			ø solidi ø solids (mm)	D
	DNM	B	C		
DUMPER 150	2"	429	464	8	3/4"
DUMPER 200	2"	429	464	8	
DUMPER 300	2"	429	464	8	

MODELLO / MODEL	DIMENSIONI POMPA in mm. PUMP DIMENSIONS in mm.			ø solidi ø solids (mm)	D
	DNM	B	C		
ARVEX 80	2"	388	408	50	3/4"
ARVEX 100	2"	397	408	50	
ARVEX 150	2"	397	448	50	
ARVEX 200	2"	397	448	50	

MODELLO / MODEL	DIMENSIONI POMPA in mm. PUMP DIMENSIONS in mm.			ø solidi ø solids (mm)	D
	DNM	B	C		
CUTTER 140	2"	415	400	---	3/4"
CUTTER 150	2"	433	464	---	
CUTTER 200	2"	433	464	---	
CUTTER 300	2"	433	464	---	

* = RIDUZIONE DA 1 1/2 A 2" / REDUCTION FROM 1 1/2 TO 2"

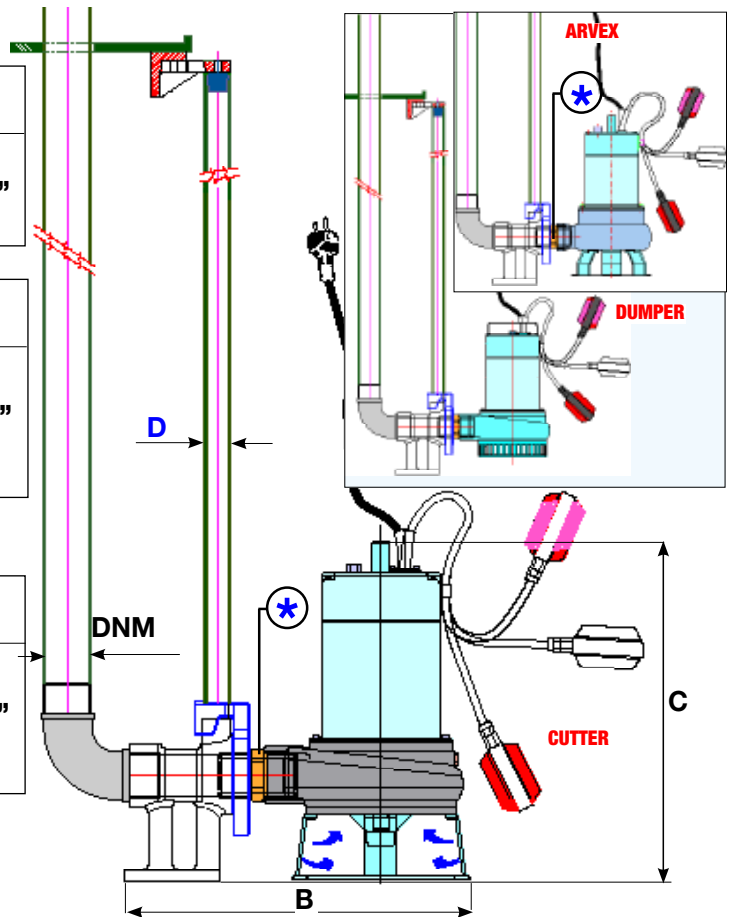

SERIE SERIES TIGER 80F - 100F - 150F - 200F - 300F - 400F

SISTEMI DI DISCESA (DN 50) PER IMPIANTI FISSI
DOWN STROKE GUIDE RAIL SYSTEM (DN 50) FOR
FIXED PLANTS

MODELLO / MODEL	DIMENSIONI POMPA in mm. PUMP DIMENSIONS in mm.			ø solidi ø solids (mm)	D
	DNM	B	C		
TIGER 80F	2"	354	420	35	3/4"
TIGER 100F	2"	354	420	50	
TIGER 150F	2"*	415	508	50*	
TIGER 200F	2"*	415	508	50*	

* = SOLO PER IMPIANTI FISSI / ONLY FOR FIXED PLANTS

SISTEMI DI DISCESA (DN 80) PER IMPIANTI FISSI
DOWN STROKE GUIDE RAIL SYSTEM (DN 80) FOR
FIXED PLANTS

MODELLO / MODEL	DIMENSIONI POMPA in mm. PUMP DIMENSIONS in mm.			ø solidi ø solids (mm)	D
	DNM	B	C		
TIGER 300F	3"	529	545	80	1"
TIGER 400F	3"	529	670	80	

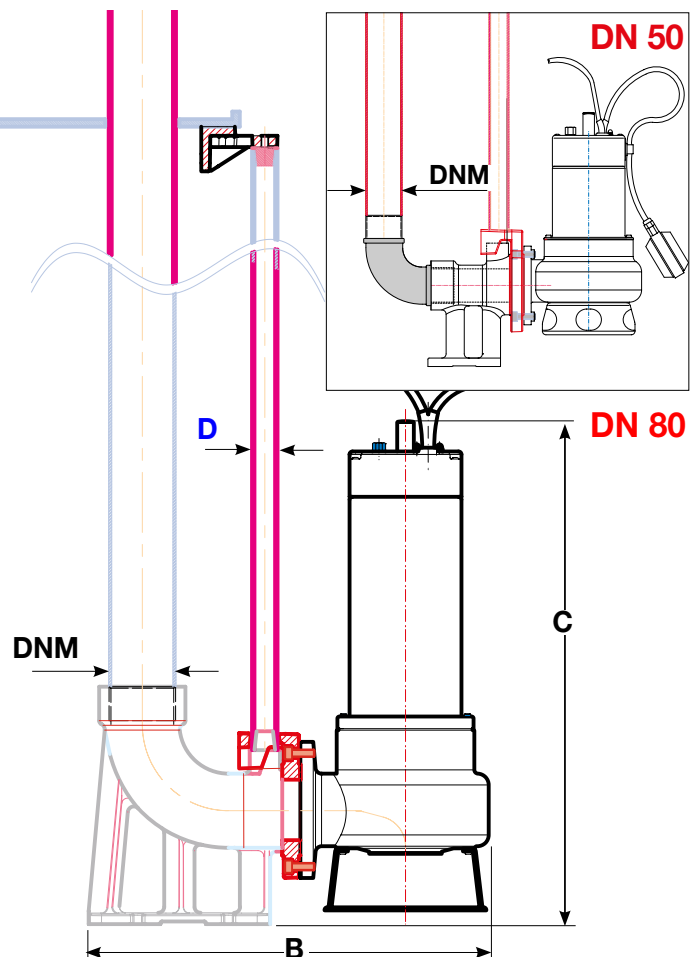

SISTEMI DI DISCESA (DN 50) PER IMPIANTI FISSI
DOWN STROKE GUIDE RAIL SYSTEM (DN 50) FOR FIXED PLANTS

MODELLO / MODEL	DIMENSIONI POMPA in mm. PUMP DIMENSIONS in mm.			ø solidi ø solids (mm)	D
	DNM	B	C		
SKIPPER 80F	2"	352	406	45	3/4"
SKIPPER 100F	2"	352	406	45	
SKIPPER 150F	2"*	401	497	50*	
SKIPPER 200F	2"*	401	497	50*	

* = SOLO PER IMPIANTI FISSI / ONLY FOR FIXED PLANTS

SISTEMI DI DISCESA (DN 80) PER IMPIANTI FISSI
DOWN STROKE GUIDE RAIL SYSTEM (DN80) FOR FIXED PLANTS

MODELLO / MODEL	DIMENSIONI POMPA in mm. PUMP DIMENSIONS in mm.			ø solidi ø solids (mm)	D
	DNM	B	C		
SKIPPER 300F	3"	520	549	80	1"
SKIPPER 400F	3"	520	670	80	

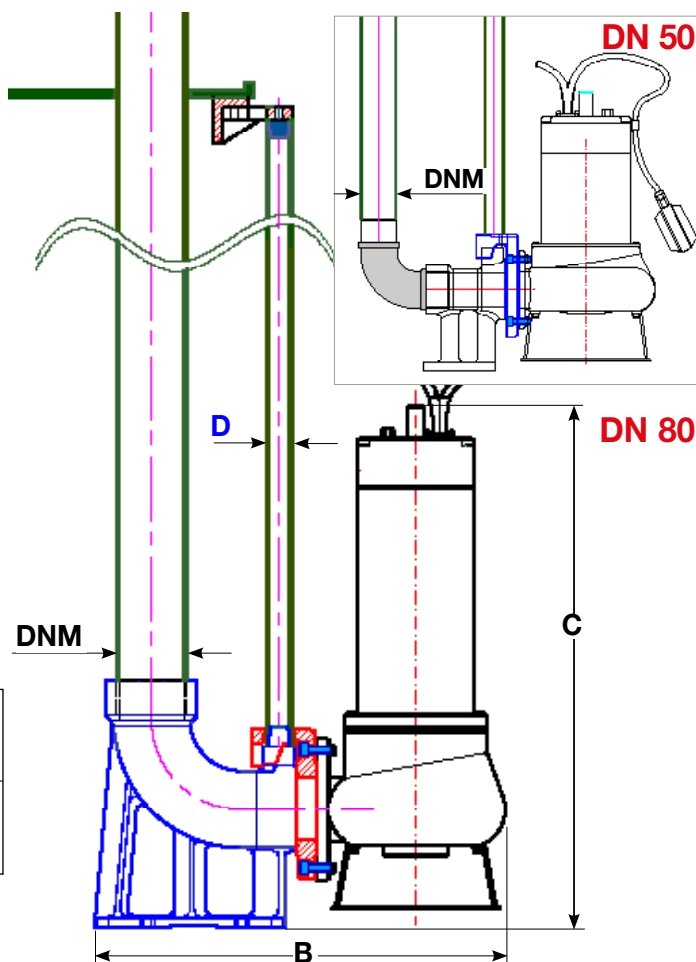

POMPE SOMMERSIBILI INOX
 SUBMERSIBLE INOX PUMPS

SERIE SERIES RIVER / TENAX 150F - 200F - 300F - 400F - 600F MONOCANALI SINGLE CHANNEL

SISTEMI DI DISCESA (DN 50) PER IMPIANTI FISSI
DOWN STROKE GUIDE RAIL SYSTEM (DN 50) FOR FIXED PLANTS

MODELLO / MODEL	DIMENSIONI POMPA PUMP DIMENSIONS in mm.			ø solidi ø solids (mm)	D
	DNM	B	C		
RIVER 150F a	2"*	256	514	50	3/4"
RIVER 200F a	2"*	256	514	50*	
TENAX 150F a	2"*	389	500	50	
TENAX 200F a	2"*	389	500	50*	

* = SOLO PER IMPIANTI FISSI / ONLY FOR FIXED PLANTS

SISTEMI DI DISCESA (DN 80) PER IMPIANTI FISSI
DOWN STROKE GUIDE RAIL SYSTEM (DN 80) FOR FIXED PLANTS

MODELLO / MODEL	DIMENSIONI POMPA in mm/ PUMP DIMENSIONS in mm.			ø solidi ø solids (mm)	D
	DNM	B	C		
RIVER 300F c	3"	623	665	50	1"
RIVER 400F c	3"	623	665	50	
RIVER 600F c	3"	623	665	50	
TENAX 300F c	3"	604	657	50	
TENAX 400F c	3"	604	657	50	
TENAX 600F c	3"	604	657	50	

c = Monocanale chiusa / Close single channel

a = Monocanale aperta / Open single channel

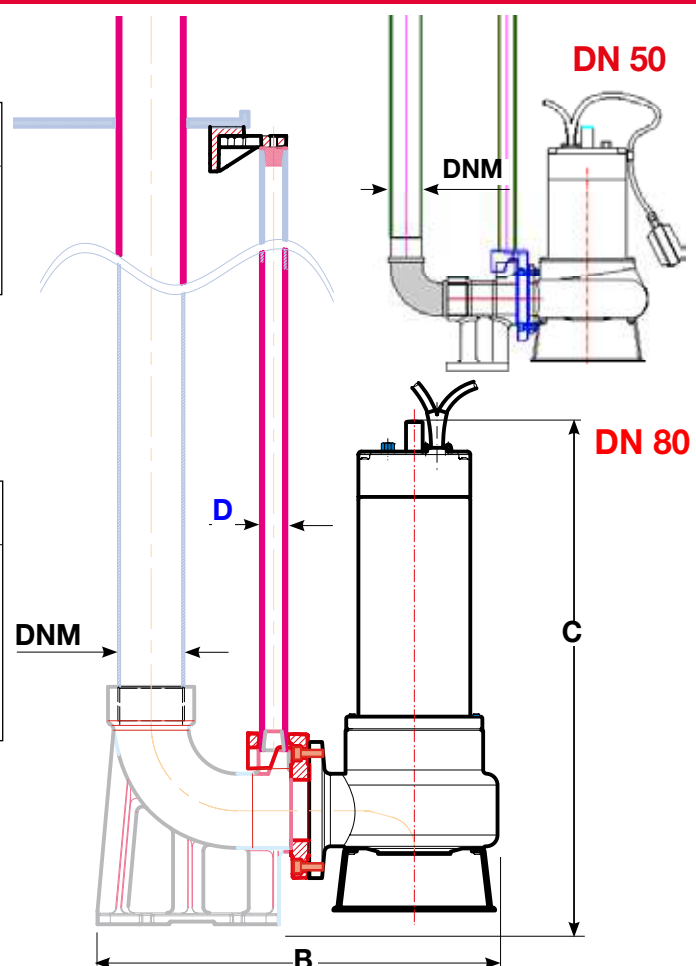

D = DIMENSIONI TUBI DISCESA / DOWN TUBES DIMENSIONS

STAZIONI AUTOMATICHE PER LA RACCOLTA E IL SOLLEVAMENTO DI ACQUE CARICHE

AUTOMATIC PUMPING STATIONS FOR THE COLLECTION AND LIFTING OF FOUL WASTEWATER



**200 LITRI
200 LITERS**

APPLICAZIONI

UTILIZZATE PER LA RACCOLTA DI ACQUE DOMESTICHE USATE DA IMMETTERE IN COLLETTORI DI SCARICO SITUATI SU DI UN DISLIVELLO SUPERIORE, O COMUNQUE PRIVI DI CADENZA GRAVITAZIONALE

APPLICATIONS

IMPLEMENTED FOR THE COLLECTION OF DOMESTIC WASTEWATER AND USED AS A LIFT STATION TO PUMP THE WASTEWATER INTO DISCHARGE COLLECTORS LOCATED AT HIGHER LEVELS OR THAT DO NOT ANYWAY HAVE A GRAVITATIONAL DROP.

TABELLA DATI TECNICI / TECHNICAL TABLE

BOX - 1		CARATTERISTICHE / FEATURES				ACCESSORI / ACCESSORIES								
		P2 (kW)	HP	Q max (l/min)	H max (m)	TIPOLOGIA GIRANTE IMPELLER TYPE	QUADRO ELETTRICO CONTROL BOARD	GALLEGGIANTE PREMONTATO SU POMPA FLOAT PREASSEMBLED ON PUMP	GALLEGGIANTE N°2 (10MT CAVO) FLOAT (10 MT CABLE)	VALVOLA DI NON RITORNO NON RETURN VALVE	GALLEGGIANTE DI EMERGENZA EMERGENCY FLOAT	KIT ALLARME (BLOCCO TERMICO)	SOUND SIGNAL WITH FLASHING SOUND SIGNAL	
SISTEMI DI DISCESA DN50 / GUIDE RAIL SYSTEM DN50	MONOFASE 1-PHASE	TIGER 80F M	0,6	0,8	260	7,0	*	X	N°2	X	*			
		TIGER 100F M	0,75	1,0	350	8,0								
		TIGER 140F M	1,1	1,5	450	11,0								
		ARVEX 80 M	0,6	0,8	300	9,5								VORTEX
		ARVEX 100 M	0,8	1,0	400	10,5								
		ARVEX 150 M	1,1	1,5	425	13,0								
		ARVEX 200 M	1,5	2,0	450	14,0								
		ARVEX BC 100 M	0,75	1,0	500	11,5								BICANALE TWIN-CHANNEL
		ARVEX BC 150 M	1,1	1,5	600	14,5								
		CUTTER 140 M	1,1	1,5	150	17,0								GRINDER
SISTEMI DI DISCESA DN50 / GUIDE RAIL SYSTEM DN50	TRIFASE 3-PHASE	TIGER 80F T	0,6	0,8	260	7,0	X		X	*				
		TIGER 100F T	0,75	1,0	350	8,0	X		X					
		TIGER 140F T	1,1	1,5	450	11,0	X		X					
		TIGER 190F T	1,5	2,0	500	13,0	X		X					
		ARVEX 80 T	0,6	0,8	300	9,5	VORTEX	X					X	
		ARVEX 100 T	0,8	1,0	400	10,5	X		X					
		ARVEX 150 T	1,1	1,5	425	13,0	X		X					
		ARVEX 200 T	1,5	2,0	450	14,0	X		X					
		ARVEX BC 100 T	0,75	1,0	500	11,5	BICANALE TWIN-CHANNEL	X					X	
		ARVEX BC 150 T	1,1	1,5	600	14,5	X		X					
		ARVEX BC 200 T	1,5	2,0	700	15,5	X		X					
		CUTTER 140 T	1,1	1,5	150	17,0	GRINDER	X					X	

DIMENSIONI IN mm / DIMENSIONS IN mm

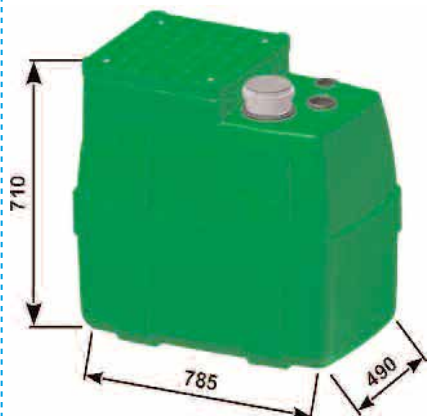

INSTALLAZIONE / INSTALLATION

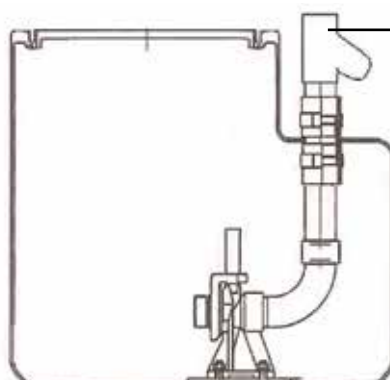

VALVOLA DI RITEGNO A PALLA
CHECK BALL VALVE

X Accessori inclusi
Included accessories

STAZIONI AUTOMATICHE PER LA RACCOLTA E IL SOLLEVAMENTO DI ACQUE CARICHE

AUTOMATIC PUMPING STATIONS FOR THE COLLECTION AND LIFTING OF FOUL WASTEWATER

APPLICAZIONI

UTILIZZATE PER LA RACCOLTA DI ACQUE DOMESTICHE USATE DA IMMETTERE IN COLLETTORI DI SCARICO SITUATI SU DI UN DISLIVELLO SUPERIORE, O COMUNQUE PRIVI DI CADENZA GRAVITAZIONALE

APPLICATIONS

IMPLEMENTED FOR THE COLLECTION OF DOMESTIC WASTEWATER AND USED AS A LIFT STATION TO PUMP THE WASTEWATER INTO DISCHARGE COLLECTORS LOCATED AT HIGHER LEVELS OR THAT DO NOT ANYWAY HAVE A GRAVITATIONAL DROP.



**600 LITRI
600 LITERS**

TABELLA DATI TECNICI / TECHNICAL TABLE

BOX - 2		CARATTERISTICHE / FEATURES				ACCESSORI / ACCESSORIES													
		P2 (kW)	HP	Q max (l/min)	H max (m)	TIPOLOGIA GIRANTE IMPELLER TYPE	QUADRO ELETTRICO CONTROL BOARD	GALLEGGIANTE PREMONTATO SU POMPA FLOAT PREASSEMBLED ON PUMP	GALLEGGIANTE N°3 (10MT CAVO) FLOAT (10 MT CABLE)	VALVOLA DI NON RITORNO NON RETURN VALVE	GALLEGGIANTE DI EMERGENZA EMERGENCY FLOAT	KIT ALLARME (BLOCCO TERMICO)	SOUND SIGNAL WITH FLASHING SOUND SIGNAL						
PERFORMANCE RIFERITE A 2 POMPE CHE LAVORANO CONTEMPORANEAMENTE THE PERFORMANCES DATA REFERS TO 2 PUMPS OPERATING SIMULTANEOUSLY		SISTEMI DI DISCESA DN50 / GUIDE RAIL SYSTEM DN50										MONOFASE 1-PHASE							
												TIGER 80F M	2x0,6	2x0,8	520	7,0	VORTEX	*	*
		TIGER 100F M	2x0,75	2x1,0	700	8,0													
		TIGER 140F M	2x1,1	2x1,5	900	11,0													
		ARVEX 80 M	2x0,6	2x0,8	600	9,5													
		ARVEX 100 M	2x0,8	2x1,0	800	10,5													
		ARVEX 150 M	2x1,1	2x1,5	850	13,0													
		ARVEX 200 M	2x1,5	2x2,0	900	14,0													
		ARVEX BC 100 M	2x0,75	2x1,0	1000	11,5	BICANALE TWIN-CHANNEL												
		ARVEX BC 150 M	2x1,1	2x1,5	1200	14,5	GRINDER												
		CUTTER 140 M	2x1,1	2x1,5	300	17,0													
		TIGER 80F T	2x0,6	2x0,8	520	7,0	VORTEX	X		X	X	X	X						
		TIGER 100F T	2x0,75	2x1,0	700	8,0		X		X	X	X	X						
		TIGER 140F T	2x1,1	2x1,5	900	11,0		X		X	X	X	X						
		TIGER 190F T	2x1,5	2x2,0	1000	13,0		X		X	X	X	X						
		ARVEX 80 T	2x0,6	2x0,8	600	9,5		X		X	X	X	X						
ARVEX 100 T	2x0,8	2x1,0	800	10,5	X			X	X	X	X								
ARVEX 150 T	2x1,1	2x1,5	850	13,0	X			X	X	X	X								
ARVEX 200 T	2x1,5	2x2,0	900	14,0	X			X	X	X	X								
ARVEX BC 100 T	2x0,75	2x1,0	1000	11,5	BICANALE TWIN-CHANNEL	X		X	X	X	X								
ARVEX BC 150 T	2x1,1	2x1,5	1200	14,5	GRINDER	X		X	X	X	X								
ARVEX BC 200 T	2x1,5	2x2,0	1400	15,5		X		X	X	X	X								
CUTTER 140 T	2x1,1	2x1,5	300	17,0		X		X	X	X	X								

DIMENSIONI IN mm / DIMENSIONS IN mm



INSTALLAZIONE / INSTALLATION

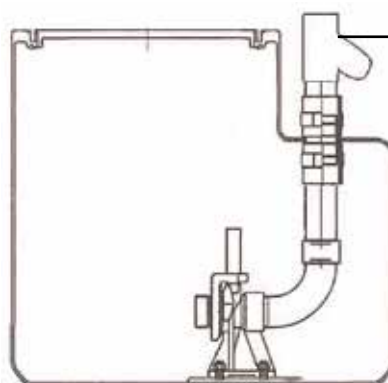

VALVOLA DI RITEGNO A PALLA
CHECK BALL VALVE

X Accessori inclusi
X Included accessories

TURBO 200 - 250



ELETTROPOMPE SOMMERSIBILI MONOBLOCCO MULTISTADIO VERTICALI IN GHISA VERTICAL SUBMERSIBLE MULTI STAGE ELECTRIC PUMPS IN CAST IRON

PREVALENZA : 39,5 mt. ÷ 44 mt.
PORTATA : 18 m³/h
POTENZA NOMINALE : 1,5 kW (2,0HP) ÷ 2,25 kW (3,0HP)

PUMP HEAD : 39,5 mt ÷ 44,0 mt
DELIVERY : 18,0 m³/h
RATED HORSEPOWER : 1,5kW (2,0HP) ÷ 2,25 kW (3,0HP)

APPLICAZIONI

- PARTICOLARMENTE INDICATE NEL SETTORE AGRICOLO PER IRRIGAZIONE, POMPAGGIO DI ACQUA DA VASCHE O SERBATOI DI PRIMA RACCOLTA, POZZI DA 8 A 10 POLLICI POCO PROFONDI 10-20 MT, BACINI E CORSI D'ACQUA
- MOVIMENTAZIONE NEL SETTORE INDUSTRIALE DI ACQUE DI RAFFREDDAMENTO E DI ALIMENTAZIONE E SCARICO.
- PRESSURIZZAZIONE CON POMPA INSERITA NEL SERBATOIO O POZZO
- FONTANE.

APPLICATIONS

- PARTICULARLY SUITED TO THE AGRICULTURAL AND FARMING SECTORS FOR IRRIGATION PURPOSES, FOR CATCH TANK AND RESERVOIR CATCH-WATER PUMP OUT, FROM 8 TO 10 INCH WELL, WITH 10- 20 MT DEEP, WATER BASIN AND WATER DRAIN FLOW PUMP OUT.
- FOR INDUSTRIAL COOLING, FEED-IN AND DISCHARGE WATER HANDLING.
- FOR PRESSURISATION, WITH TANK OR WELL PUMP INCLUSION.
- FOR FOUNTAINS.



ARVEN[®]
WATER PUMPS

CARATTERISTICHE DI COSTRUZIONE:

- MOTORE A BAGNO D'OLIO (BIODEGRADABILE E DIELETTRICO) PER RAFFREDDAMENTO E LUBRIFICAZIONE CUSCINETTI.
- DOPPIO ANELLO DI TENUTA LATO MOTORE.
- TENUTA MECCANICA A BAGNO D'OLIO.
- IMMERSIONE MASSIMA: mt. 10.
- GRADO DI PROTEZIONE IP 68.
- CLASSE DI ISOLAMENTO: F.
- TEMPERATURA MAX. LIQUIDO POMPATO: 35°C.
- VERSIONI:
 - Monofase: 220-277V / 50Hz con protettore termico incorporato.
 - Trifase: 220-277V/ 50Hz o 380 – 480V /50Hz con protezione da sovraccarico a cura dell'utente.
- VERSIONI MONOFASI AUTOMATICHE CON GALLEGGIANTE fino a 2,0 HP
- VERSIONI MONOFASI da 3,0 Hp solo MANUALI SENZA GALLEGGIANTE.
- CAVO STANDARD:
 - Monofase: H07RN-F 10mt completa di quadro elettrico con spezzone 0,7 metri senza spina.
 - Trifase: H07RN-F 10mt senza spina.

SPECIALI VOLTAGGI E FREQUENZE A RICHIESTA.

DESIGN ENGINEERING:

- OIL BATH MOTOR (BIODEGRADABLE AND DIELECTRIC) FOR COOLING AND BEARING LUBRICATION.
- DOUBLE SEALING RING - ENGINE FACE.
- OIL BATH MECHANICAL SEALS.
- PERMISSIBLE DRAUGHT OF WATER: 20 m.
- IP 68 PROTECTION CLASS.
- CLASS "F" INSULATION.
- MAX. PUMPED LIQUID TEMPERATURE: 35°C.
- VERSIONS:
 - Single Phase: 220-277V/50Hz with built in thermal protection.
 - Three Phases: 220-277V/50Hz or 380-480V/50Hz with overload protection care of the User.
- AUTOMATIC SINGLE PHASE VERSIONS up to 1,1 kW (2,0 HP).
- SINGLE PHASE VERSIONS from 1,5 kW (3,0 HP) only manual, without floater
- STANDARD CABLE FEATURES:
 - Single Phase: H07RN-F 10mt complete with power supply box 0,7 m cable section, without connection plug.
 - Three Phases: H07RN-F 10mt without connection plug.

CUSTOMISED VOLTAGE AND FREQUENCY RATING AVAILABLE ON DEMAND.

TABELLA MATERIALI / MATERIALS TABLE:

Pos.	Componente / Component	Materiale / Materials	
A	Coperchio / Cover	GHISA (G20) / CAST IRON	
B	Guarnizione / Gasket	GOMMA DIELETTICA DIELECTRIC RUBBER	
C	Carcassa motore / Motor housing	GHISA (G20) / CAST IRON	
D	Albero / Shaft	ACCIAIO INOX AISI 416 DIN 1.4005 / STAINLESS STEEL	
E	Tenuta meccanica / Mechanical seal	Lato Motore / Motor side	DOPPIO ANELLO DI TENUTA NBR NBR DOUBLE SEALING RING
		Lato pompa / Pump side	CARBURIO DI SILICIO/ALLUMINA SILICON CARBIDE-ALUMINA
F	O-ring	NBR	
G	Flangia inferiore / Upper flange	GHISA (G20) / CAST IRON	
H	Girante / Impeller	ACCIAIO INOX AISI 304 DIN 1.4301 / STAINLESS STEEL	
I	Diffusore / Diffuser	TECNOPOLIMERO/TECNOPOLYMER	
L	Piattello / Disk base	ACCIAIO / STEEL	
M	Griglia / Greed	ACCIAIO INOX AISI 304 DIN 1.4301 / STAINLESS STEEL	

TURBO 200 - 250

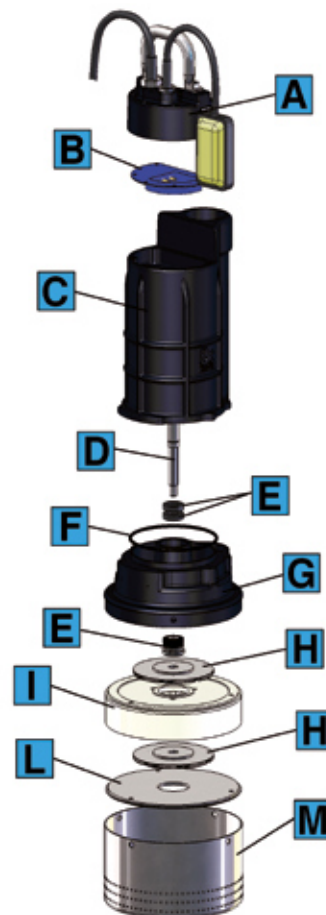

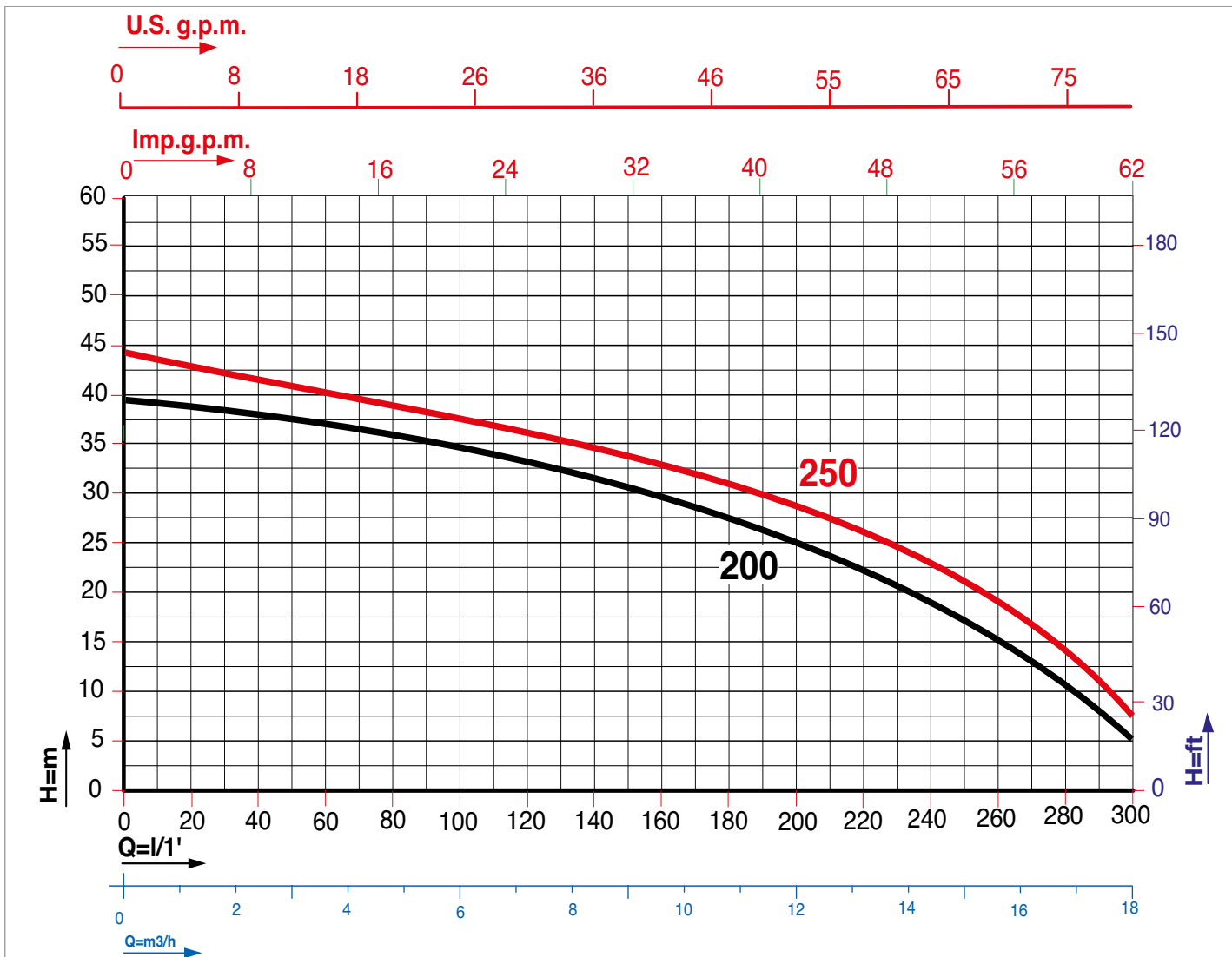

Caratteristiche di funzionamento a 2800 rpm 50Hz - Performances at 2800 rpm 50 Hz

Le prestazioni valgono per liquidi con densità $\rho = 1,0 \text{ kg/dm}^3$ ed una viscosità $\nu = 1 \text{ mm}^2/\text{s}$ / The performance data holds true for liquids with a $\rho = 1,0 \text{ kg/dm}^3$ density and a $\nu = 1 \text{ mm}^2/\text{s}$ viscosity.

MODELLO MODEL	VOLTAGGIO VOLTAGE	DATI ELETTRICI / ELECTRICAL DATA					DATI IDRAULICI / HYDRAULIC DATA								
		P1 max	P2 nom.		I max	Condensatore Capacitor	m³/h	0	3	6	9	12	15	18	
50 Hz		kW	kW	HP	Ampere	µF	VC	l/min.	0	50	100	150	200	250	300
TURBO 200 M	1 x 220-230V	2,9	1,5	2,0	15,0	40	450	H (m)	39,5	37,5	34,5	30,0	25,0	16,0	5,0
TURBO 200 T	3 x 380-400V	2,7	1,5	2,0	5,0	---	---		39,5	37,5	34,5	30,0	25,0	16,0	5,0
TURBO 250 M	1 x 220-230V	4,0	2,25	3,0	18,0	40	450		44,0	41,0	37,0	34,0	28,5	20,5	7,0
TURBO 250 T	3 x 380-400V	3,8	2,25	3,0	6,5	---	---		44,0	41,0	37,0	34,0	28,5	20,5	7,0

PRESSIONE TOTALE IN METRI COLONNA ACQUA
 TOTAL PUMP HEAD IN WATER COLUMN METERS

DIMENSIONI e PESI / SIZE AND WEIGHT DATA:

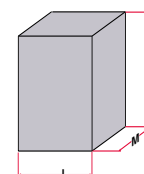
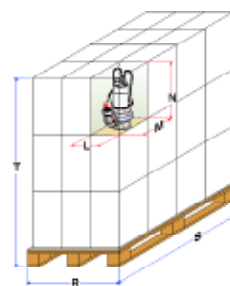
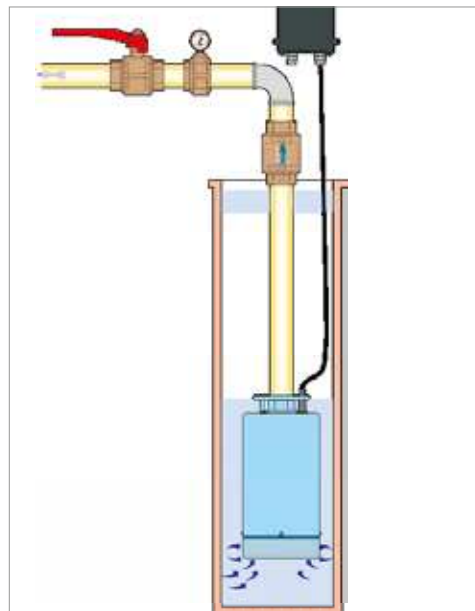
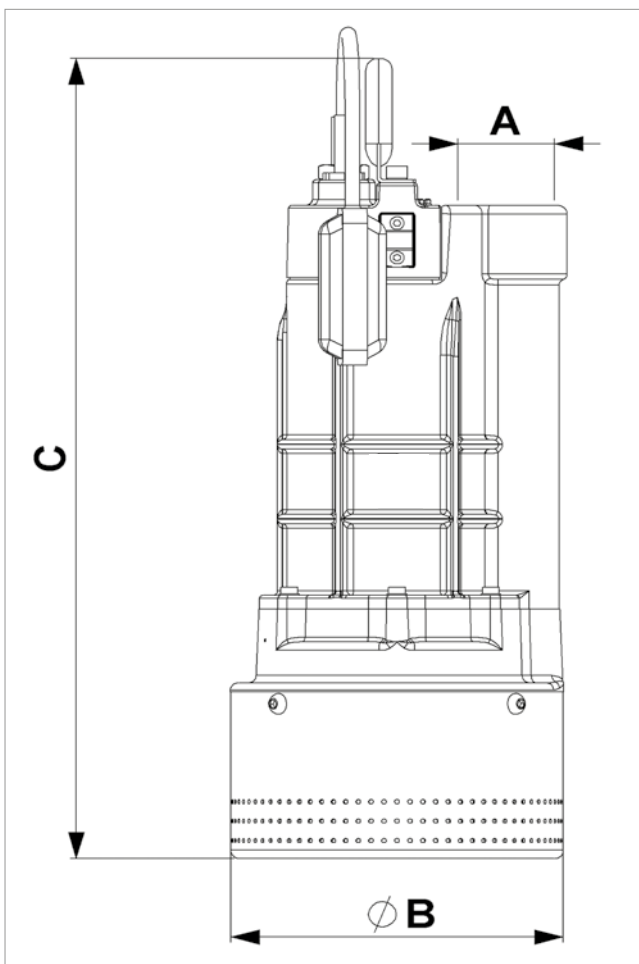

POMPE SOMMERGIBILI IN GHISA
SUBMERSIBLE PUMPS IN CAST IRON

MODELLO / MODEL	DIMENSIONI POMPA in mm. / PUMP DIMENSIONS in mm.		
	A	B	C
TURBO 200	2"	203	550,5
TURBO 250	2"	203	550,5

MODELLO / MODEL	DIMENSIONI SCATOLA / PACKING DIMENSIONS				DIMENSIONI PALLET / PALLET DIMENSIONS				
	L	M	N	Peso / Weight	R	S	T	nr.	Peso / Weight
	mm.	mm.	mm.	Kg.	mm.	mm.	mm.	scatole/cartons	Kg.
TURBO 200	580	260	370	38,0	800	1200	2060	28	1092
TURBO 250	580	260	370	38,0	800	1200	2060	28	1092

TURBO 300-400-500



ELETTROPOMPE SOMMERGIBILI MONOBLOCCO MULTISTADIO VERTICALI VERTICAL SUBMERSIBLE MULTI STAGE ELECTRIC PUMPS

PREVALENZA : 45 ÷ 54 mt.
PORTATA : 24 ÷ 30 m³/h
POTENZA NOMINALE : 2,2 kW (3HP) ÷ 3,7 kW (5 HP)

PUMP HEAD : 45,0 mt ÷ 54,0 mt
DELIVERY : 24,0 m³/h ÷ 30,0 m³/h
RATED HORSEPOWER : 2,2 kW (3,0HP) ÷ 3,7 kW (5,0HP)

APPLICAZIONI

- PARTICOLARMENTE INDICATE NEL SETTORE AGRICOLO PER IRRIGAZIONE, POMPAGGIO DI ACQUA DA VASCHE O SERBATOI DI PRIMA RACCOLTA, POZZI DA 8 A 10 POLLICI POCO PROFONDI 10-20 MT, BACINI E CORSI D'ACQUA.
- MOVIMENTAZIONE NEL SETTORE INDUSTRIALE DI ACQUE DI RAFFREDDAMENTO E DI ALIMENTAZIONE E SCARICO.
- PRESSURIZZAZIONE CON POMPA INSERITA NEL SERBATOIO O POZZO.
- FONTANE.

APPLICATIONS

- PARTICULARLY SUITED TO THE AGRICULTURAL AND FARMING SECTORS FOR IRRIGATION PURPOSES, FOR CATCH TANK AND RESERVOIR CATCH-WATER PUMP OUT, FROM 8 TO 10 INCH WELL, WITH 10-20 MT DEEP, WATER BASIN AND WATER DRAIN FLOW PUMP OUT.
- FOR INDUSTRIAL COOLING, FEED-IN AND DISCHARGE WATER HANDLING.
- FOR PRESSURISATION, WITH TANK OR WELL PUMP INCLUSION.
- FOR FOUNTAINS.



CARATTERISTICHE DI COSTRUZIONE:

- MOTORE A BAGNO D'OLIO (BIODEGRADABILE E DIELETTRICO) PER RAFFREDDAMENTO E LUBRIFICAZIONE CUSCINETTI.
- ANELLO DI TENUTA LATO MOTORE
- TENUTA MECCANICA A BAGNO D'OLIO.
- IMMERSIONE MASSIMA: mt. 10.
- GRADO DI PROTEZIONE IP 68.
- CLASSE DI ISOLAMENTO: F.
- TEMPERATURA MAX. LIQUIDO POMPATO: 35°C.
- VERSIONI:
 Monofase: 220-2770V/ 50Hz con protettore termico incorporato (SOLO VERSIONE 3HP).
- Trifase: 380-400V/ 50Hz con protezione da sovraccarico a cura dell'utente.
- CAVO STANDARD:
 Monofase: 10 mt H07RN-F senza spina (SOLO VERSIONE 3HP).
- Trifase: 10 mt H07RN-F senza spina.

OPZIONI:

- CAVO PIU' LUNGO SU RICHIESTA.
- SPECIALE VOLTAGGIO E FREQUENZE A RICHIESTA.

ACCESSORI DISPONIBILI A RICHIESTA:

- QUADRO ELETTRICO TRIFASE DI PROTEZIONE E COMANDO AUTOMATICO A MEZZO GALLEGGIANTE ELETTROMECCANICO.
- GALLEGGIANTE 10-20mt. DI CAVO.
- RACCORDI IN ALLUMINIO.
- RIDUZIONE DA 3" A 2".

DESIGN ENGINEERING:

- OIL BATH MOTOR (BIODEGRADABLE AND DIELECTRIC) FOR COOLING AND BEARING LUBRICATION.
- SEALING RING - ENGINE FACE.
- OIL BATH MECHANICAL SEALS.
- PERMISSIBLE EIGHT OF WATER: 10 m.
- IP 68 PROTECTION CLASS.
- CLASS "F" INSULATION.
- MAX. PUMPED LIQUID TEMPERATURE: 35°C.
- VERSIONS:
 Single Phase: 220-277V/50Hz with built in thermal protection. (ONLY 3HP VERSION)
- Three Phases: 380-400V/50Hz with overload protection care of the User.
- STANDARD CABLE FEATURES:
 Single Phase: 10 mt H07RN-F without connection plug (ONLY 3HP VERSION).
- Three Phases: 10 mt H07RN-F without connection plug.

OPTIONS:

- CABLE LONGER THAN STANDARD VERSION ON REQUEST.
- CUSTOMIZE VOLTAGE AND FREQUENCY RATING AVAILABLE ON DEMAND.

ACCESSORIES AVAILABLE ON DEMAND:

- THREE PHASES ELECTRICAL SAFETY POWER SUPPLY BOX WITH AUTOMATIC ELECTROMECHANICAL FLOATER CONTROLS.
- FLOATER CONTROLS 10-20mt. ELECTRIC CABLE.
- ALUMINIUM CONNECTION PIECES.
- RIDUCTION FROM 3" TO 2".

TABELLA MATERIALI / MATERIALS TABLE:

Pos.	Componente / Component	Materiale / Materials	
A	Coperchio / Cover	GHISA (G20) / CAST IRON	
B	Guarnizione / Gasket	GOMMA DIELETTRICA DIELECTRIC RUBBER	
C	Carcassa motore / Motor housing	GHISA (G20) / CAST IRON	
D	Albero (lato pompa) / Shaft (pump side)	ACCIAIO INOX AISI 316 DIN 1.4401 / STAINLESS STEEL	
E	Tenuta meccanica / Mechanical seal	Lato Motore / Motor side	ANELLO DI TENUTA NBR NBR SEALING RING
		Lato pompa / Pump side	CARBURO DI SILICIO SILICON CARBIDE
G	Flangia inferiore / Upper flange	GHISA (G20) / CAST IRON	
H	Girante / Impeller	ACCIAIO INOX AISI 304 DIN 1.4301 / STAINLESS STEEL	
I	Diffusore / Diffuser	GHISA (G20) / CAST IRON	
L	Piattello / Disk	ACCIAIO / STEEL	
M	Griglia / Greed		
N	Piatto / Disk base	GHISA (G20) / CAST IRON	

TURBO 300-400-500

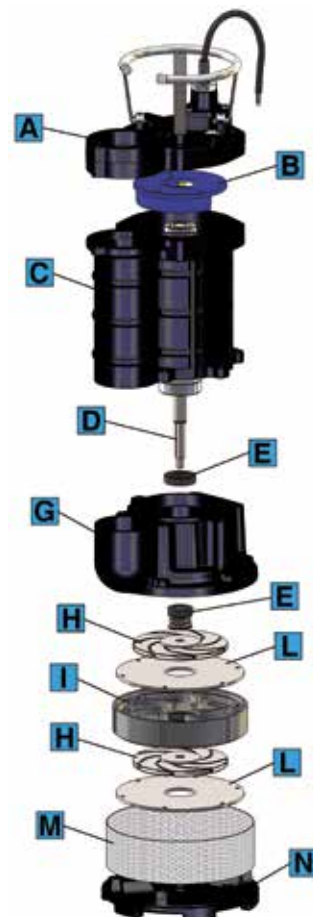

POMPE SOMMERSIBILI IN GHISA
SUBMERSIBLE PUMPS IN CAST IRON

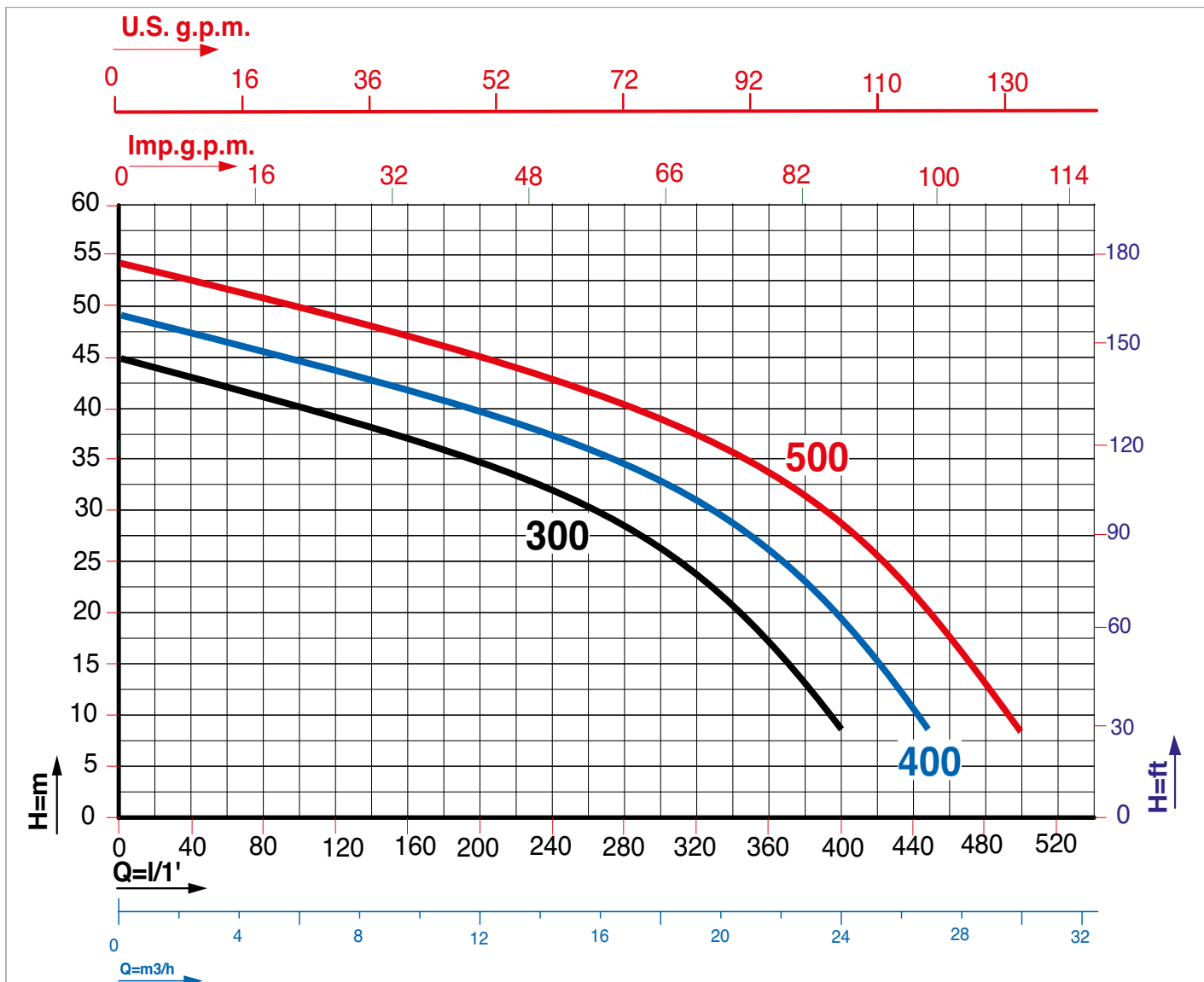

Caratteristiche di funzionamento a 2850 rpm 50Hz - Performances at 2850 rpm 50 Hz

Le prestazioni valgono per liquidi con densità $\rho = 1,0 \text{ kg/dm}^3$ ed una viscosità $\nu = 1 \text{ mm}^2/\text{s}$ / The performance data holds true for liquids with a $\rho = 1,0 \text{ kg/dm}^3$ density and a $\nu = 1 \text{ mm}^2/\text{s}$ viscosity.

MODELLO MODEL	VOLTAGGIO VOLTAGE	DATI ELETTRICI / ELECTRICAL DATA						DATI IDRAULICI / HYDRAULIC DATA												
		P1 max	P2 nom.		I max	Condensatore Capacitor		m³/h		H (m)										
	50 Hz	kW	kW	HP	Ampere	µF	VC	3	9	15	24	27	30	50	150	250	400	450	500	
TURBO 300 M	1 x 220-230V	4,5	2,2	3,0	19,0		450	43,0	37,5	31,0	8,0	---	---							
TURBO 300 T	3 x 380-400V	4,0	2,2	3,0	7,0	--	---	43,0	37,5	31,0	8,0	---	---							
TURBO 400 T	3 x 380-400V	5,0	3,0	4,0	8,8	---	---	47,0	42,5	37,0	19,5	8,0	---							
TURBO 500 T	3 x 380-400V	6,0	3,7	5,0	9,8	---	---	52,0	47,0	42,0	28,0	20,0	8,0							

PRESSIONE TOTALE IN METRI COLONNA ACQUA
 TOTAL PUMP HEAD AND WATER COLUMN HEIGHT (m)

DIMENSIONI e PESI / SIZE AND WEIGHT DATA:

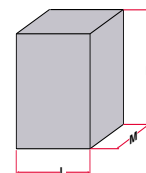
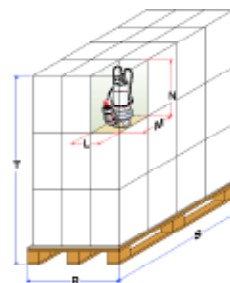
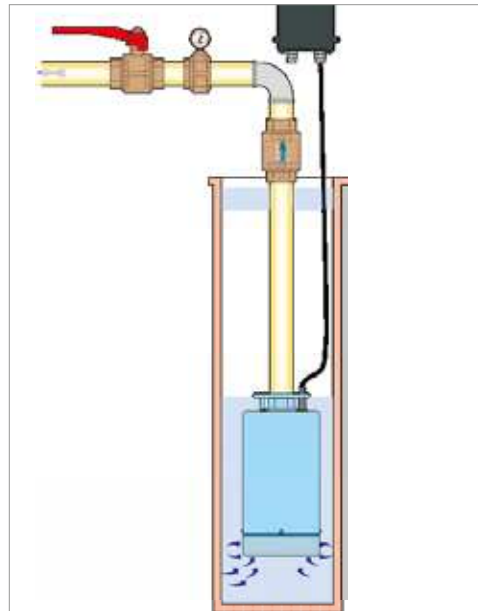
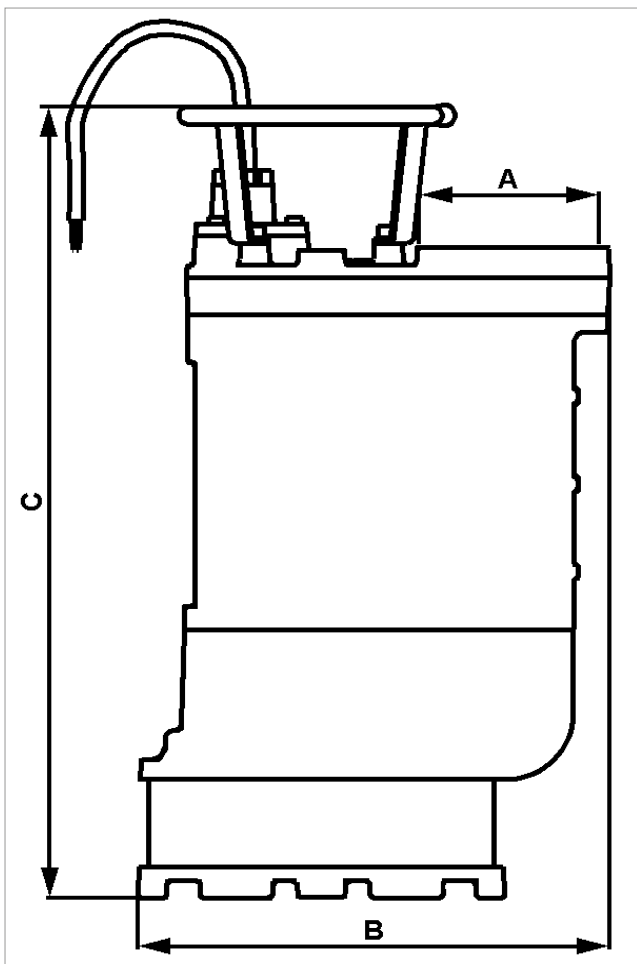

POMPE SOMMERSIBILI IN GHISA
SUBMERSIBLE PUMPS IN CAST IRON

MODELLO / MODEL	DIMENSIONI POMPA in mm. / PUMP DIMENSIONS in mm.		
	A	B	C
TURBO 300	3"	299	542,5
TURBO 400	3"	299	542,5
TURBO 500	3"	299	542,5

MODELLO / MODEL	DIMENSIONI CASSA IN LEGNO / WOODEN CASE				DIMENSIONI PALLET / PALLET DIMENSIONS				
	L	M	N	Peso / Weight	R	S	T	nr.	Peso / Weight
	mm.	mm.	mm.	Kg.	mm.	mm.	mm.	wooden case	Kg.
TURBO 300	715	395	370	60,0	715	790	2200	12	720
TURBO 400	715	395	370	61,0	715	790	2200	12	732
TURBO 500	715	395	370	62,0	715	790	2200	12	744

TURBO 750-1000



ELETTROPOMPE SOMMERSIBILI MONOBLOCCO MULTISTADIO VERTICALI IN GHISA **VERTICAL SUBMERSIBLE MULTI STAGE ELECTRIC PUMPS IN CAST IRON**

PREVALENZA : 70 ÷ 80 mt.
PORTATA : 30 m³/h
POTENZA NOMINALE : 5,5 kW (7,5 HP) ÷ 7,5 kW (10 HP)

PUMP HEAD : 70,0 mt ÷ 80,0 mt
DELIVERY : 30,0 m³/h
RATED HORSEPOWER : 5,5 kW (7,5 HP) ÷ 7,5 kW (10,0 HP)

APPLICAZIONI

- PARTICOLARMENTE INDICATE NEL SETTORE AGRICOLO PER IRRIGAZIONE, POMPAGGIO DI ACQUA DA VASCHE O SERBATOI DI PRIMA RACCOLTA, POZZI DA 8 A 10 POLLICI POCO PROFONDI 10-20 MT, BACINI E CORSI D'ACQUA.
- MOVIMENTAZIONE NEL SETTORE INDUSTRIALE DI ACQUE DI RAFFREDDAMENTO E DI ALIMENTAZIONE E SCARICO.
- PRESSURIZZAZIONE CON POMPA INSERITA NEL SERBATOIO O POZZO.
- FONTANE.

APPLICATIONS

- PARTICULARLY SUITED TO THE AGRICULTURAL AND FARMING SECTORS FOR IRRIGATION PURPOSES, FOR CATCH TANK AND RESERVOIR CATCH-WATER PUMP OUT, FROM 8 TO 10 INCH WELL, WITH 10-20 MT DEEP, WATER BASIN AND WATER DRAIN FLOW PUMP OUT.
- FOR INDUSTRIAL COOLING, FEED-IN AND DISCHARGE WATER HANDLING.
- FOR PRESSURISATION, WITH TANK OR WELL PUMP INCLUSION.
- FOR FOUNTAINS.

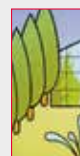

ARVEN[®]
WATER PUMPS

CARATTERISTICHE DI COSTRUZIONE:

- MOTORE A BAGNO D'OLIO (BIODEGRADABILE E DIELETTRICO) PER RAFFREDDAMENTO E LUBRIFICAZIONE CUSCINETTI.
- ANELLO DI TENUTA LATO MOTORE
- TENUTA MECCANICA A BAGNO D'OLIO.
- IMMERSIONE MASSIMA: mt. 10.
- GRADO DI PROTEZIONE IP 68.
- CLASSE DI ISOLAMENTO: F.
- TEMPERATURA MAX. LIQUIDO POMPATO: 35°C.
- VERSIONI:
Trifase: 380-400V/ 50Hz con protezione da sovraccarico a cura dell'utente.
- CAVO STANDARD:
Trifase: 10 mt H07RN-F senza spina.

OPZIONI:

- CAVO PIU' LUNGO SU RICHIESTA.
- SPECIALE VOLTAGGIO E FREQUENZE A RICHIESTA.

ACCESSORI DISPONIBILI A RICHIESTA:

- QUADRO ELETTRICO TRIFASE DI PROTEZIONE E COMANDO AUTOMATICO A MEZZO GALLEGGIANTE ELETTROMECCANICO.
- GALLEGGIANTE 10-20mt. DI CAVO.
- RACCORDI IN ALLUMINIO.
- RIDUZIONE DA 4" A 3".

DESIGN ENGINEERING:

- OIL BATH MOTOR (BIODEGRADABLE AND DIELECTRIC) FOR COOLING AND BEARING LUBRICATION.
- SEALING RING - ENGINE FACE.
- OIL BATH MECHANICAL SEALS.
- PERMISSIBLE HEIGHT OF WATER: 10 m.
- IP 68 PROTECTION CLASS.
- CLASS "F" INSULATION.
- MAX. PUMPED LIQUID TEMPERATURE: 35°C.
- VERSIONS:
Three Phases: 380-400V/50Hz with overload protection care of the User.
- STANDARD CABLE FEATURES:
Three Phases: 10 mt H07RN-F without connection plug.

OPTIONS:

- CABLE LONGER THAN STANDARD VERSION ON REQUEST.
- CUSTOMIZE VOLTAGE AND FREQUENCY RATING AVAILABLE ON DEMAND.

ACCESSORIES AVAILABLE ON DEMAND:

- THREE PHASES ELECTRICAL SAFETY POWER SUPPLY BOX WITH AUTOMATIC ELECTROMECHANICAL FLOATER CONTROLS.
- FLOATER CONTROLS 10-20mt. ELECTRIC CABLE.
- ALUMINIUM CONNECTION PIECES .
- RIDUCTION FROM 4" TO 3".

TABELLA MATERIALI / MATERIALS TABLE:

Pos.	Componente / Component	Materiale / Materials
A	Coperchio / Cover	GHISA (G20) / CAST IRON
B	Piattello contatti elettrici / Plate electrical contacts	PLASTICA SPECIALE SPECIAL PLASTIC
C	Carcassa motore / Motor housing	GHISA (G20) / CAST IRON
D	Albero (lato pompa) / Shaft (pump side)	ACCIAIO INOX AISI 316 DIN 1.4401 / STAINLESS STEEL
E	Tenuta meccanica / Mechanical seal	Lato Motore / Motor side ANELLO DI TENUTA NBR NBR SEALING RING
		Lato pompa / Pump side CARBURO DI SILICIO SILICON CARBIDE
G	Flangia inferiore / Upper flange	GHISA (G20) / CAST IRON
H	Girante / Impeller	ACCIAIO INOX AISI 304 DIN 1.4301 / STAINLESS STEEL
I	Diffusore / Diffuser	GHISA (G20) / CAST IRON
L	Piattello / Disk	ACCIAIO / STEEL
M	Griglia / Greed	
N	Piatto / Disk base	GHISA (G20) / CAST IRON

TURBO 750 - 1000

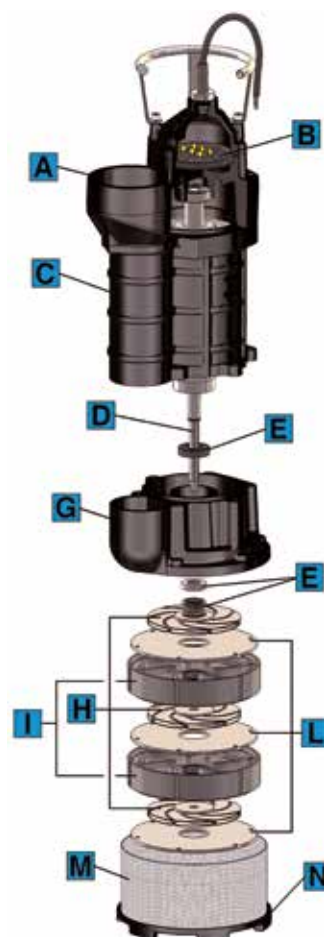

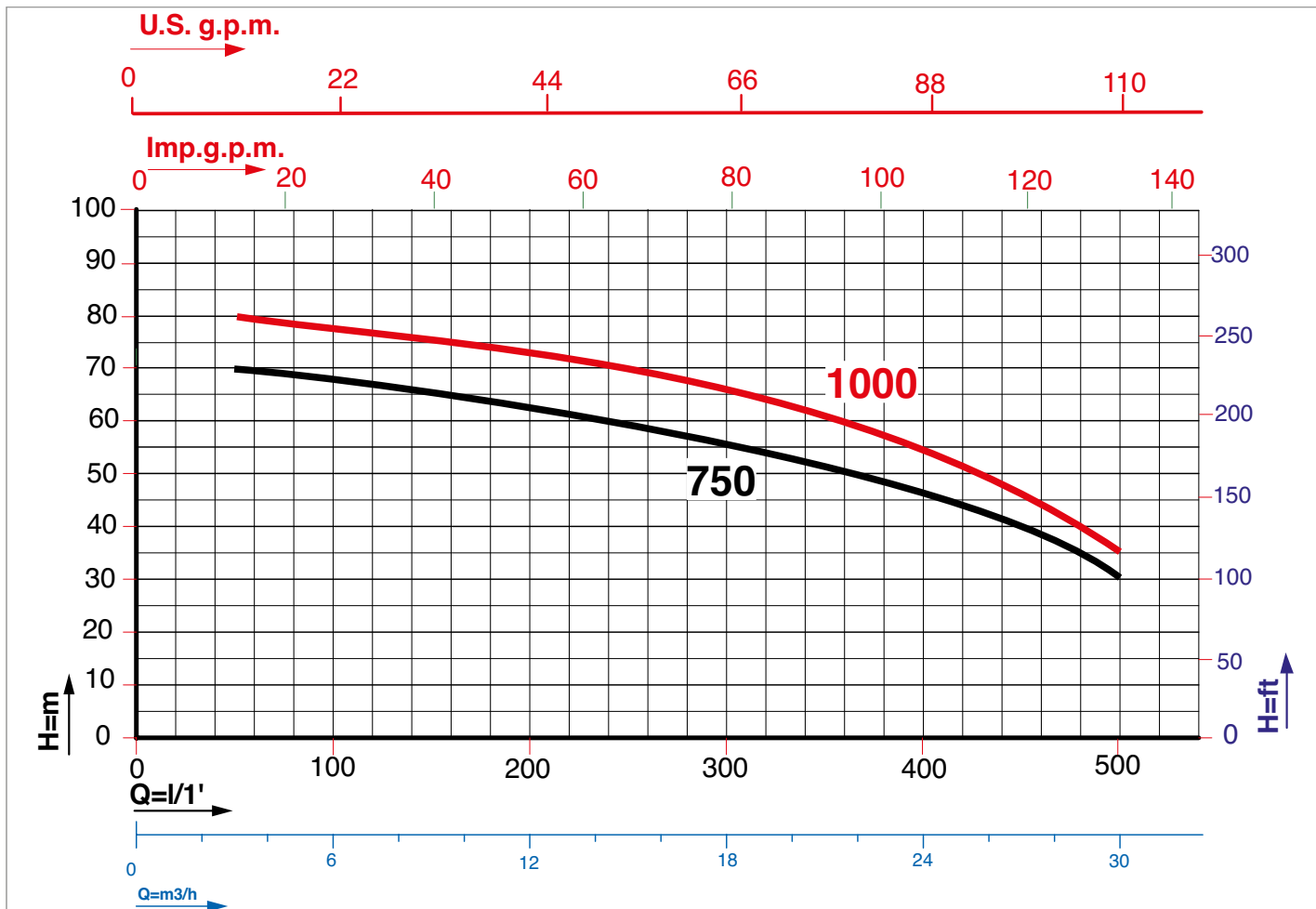

Caratteristiche di funzionamento a 2850 rpm 50Hz - Performances at 2850 rpm 50 Hz

Le prestazioni valgono per liquidi con densità $\rho = 1,0 \text{ kg/dm}^3$ ed una viscosità $\nu = 1 \text{ mm}^2/\text{s}$ / The performance data holds true for liquids with a $\rho = 1,0 \text{ kg/dm}^3$ density and a $\nu = 1 \text{ mm}^2/\text{s}$ viscosity.

MODELLO MODEL	VOLTAGGIO VOLTAGE 50 Hz	DATI ELETTRICI / ELECTRICAL DATA						DATI IDRAULICI / HYDRAULIC DATA				
		P1 max kW	P2 nom.		I max Ampere	Condensatore Capacitor		H (m)				
			kW	HP		μF	VC	3	9	15	24	30
TURBO 750 T	3 x 380-400V	7,3	5,5	7,5	12,6	---	---	70,0	65,0	60,0	48,0	30,0
TURBO 1000 T	3 x 380-400V	10,1	7,5	10,0	20,0	---	---	80,0	75,0	70,0	55,0	35,0

PREVALENZA TOTALE IN METRI COLONNA ACQUA
TOTAL PUMP HEAD AND WATER COLUMN HEIGHT IN m.

DIMENSIONI e PESI / SIZE AND WEIGHT DATA:

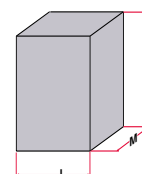
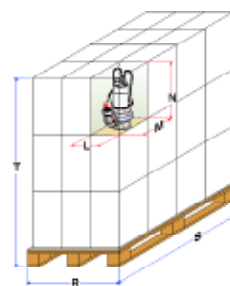
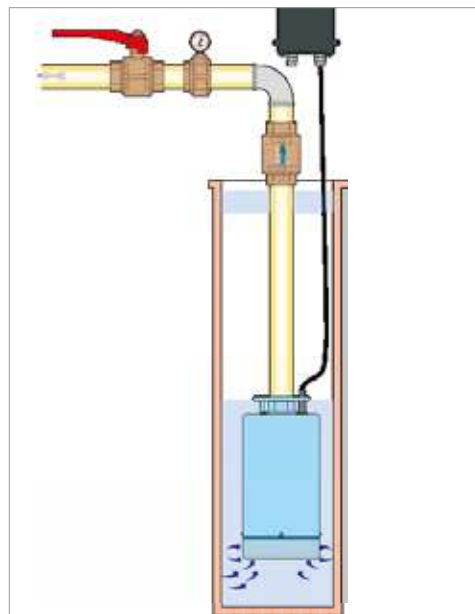
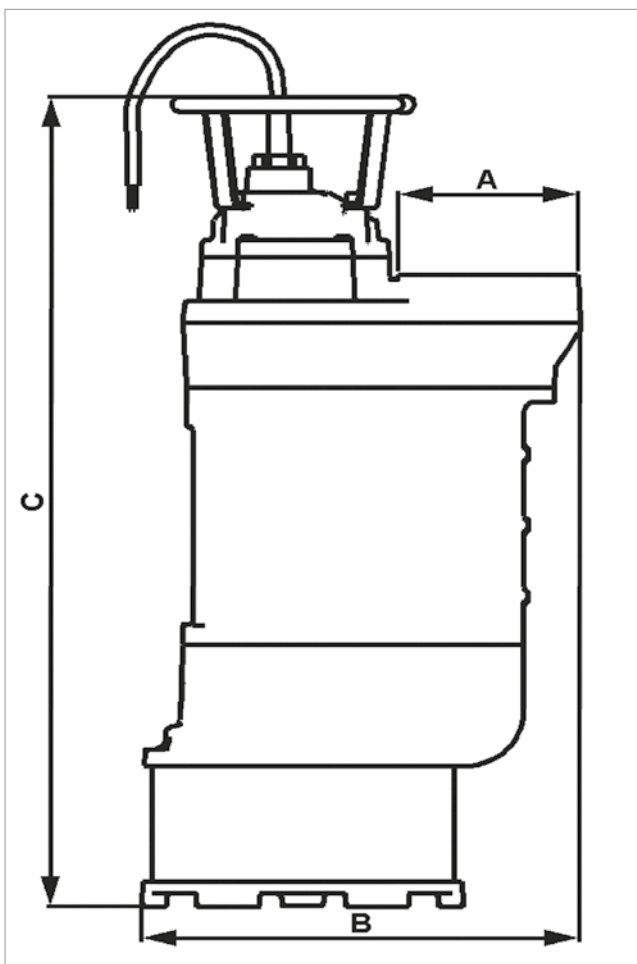

MODELLO / MODEL	DIMENSIONI POMPA in mm. / PUMP DIMENSIONS in mm.		
	A	B	C
TURBO 750	4"	318	645
TURBO 1000	4"	318	645

MODELLO / MODEL	DIMENSIONI CASSE IN LEGNO / WOODEN CASE				DIMENSIONI PALLET / PALLET DIMENSIONS				
	L	M	N	Peso / Weight	R	S	T	nr.	Peso / Weight
	mm.	mm.	mm.	Kg.	mm.	mm.	mm.	wooden case	Kg.
TURBO 750	700	800	330	82,0	700	800	2200	6	515
TURBO 1000	700	800	330	92,0	700	800	2200	6	575

TURBO L

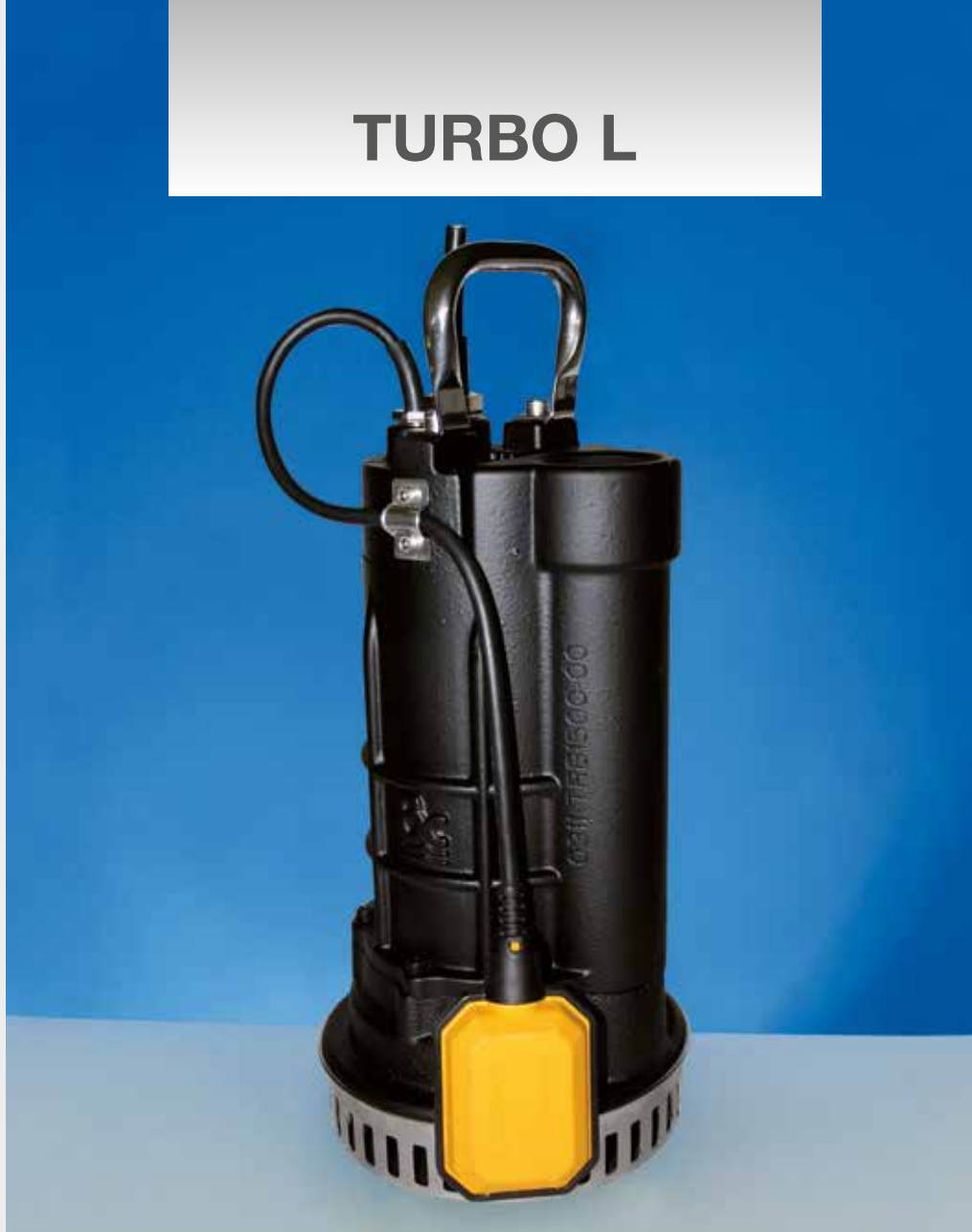

ELETTROPOMPE SOMMERSIBILI DRENAGGIO PER ACQUE SPORCHE E LEGGERMENTE SABBIOSE SUBMERSIBLE ELECTRIC PUMPS FOR LIGHTLY SANDY FOUL WASTEWATER DRAINAGE

PREVALENZA : 18 mt.
PORTATA : 24 m³/h
POTENZA NOMINALE : 1,5 kW

PUMP HEAD : 18,0 mt
DELIVERY : 24,0 m³/h
RATED HORSEPOWER : 1,5 kW

APPLICAZIONI

- SVUOTAMENTO DI CANTINE, AUTORIMESSE, SCANTINATI
- PARTICOLARMENTE ADATTE PER CANTIERISTICA.
- SVUOTAMENTO DI PISCINE VASCHE IN GENERE E SERBATOI.
- SVUOTAMENTO DA ACQUE PIOVANE, D'INFILTRAZIONE, DI POZZETTI O VASCHE DI RACCOLTA.
- IRRIGAZIONE ORTI E GIARDINI.

APPLICATIONS

- CELLAR, GARAGE AND BASEMENT PUMP OUT.
- PARTICULARLY SUITED TO CONSTRUCTION WORK SITES
- SWIMMING POOLS, ALL SORTS OF VATS, TANKS AND RESERVOIR PUMP OUT.
- RAIN, SEEPAGE, SUMP PIT AND CATCH TANK WATER PUMP OUT.
- GARDEN AND VEGETABLE-GARDEN IRRIGATION.

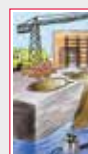

ARVEN[®]
WATER PUMPS

CARATTERISTICHE DI COSTRUZIONE:

- MOTORE A BAGNO D'OLIO (BIODEGRADABILE E DIELETTRICO) PER RAFFREDDAMENTO E LUBRIFICAZIONE CUSCINETTI.
- ANELLO DI TENUTA LATO MOTORE
- TENUTA MECCANICA A BAGNO D'OLIO.
- TENUTA MECCANICA A BAGNO D'OLIO.
- IMMERSIONE MASSIMA: mt. 5.
- GRADO DI PROTEZIONE IP 68.
- CLASSE DI ISOLAMENTO: F.
- TEMPERATURA MAX. LIQUIDO POMPATO: 35°C.
- VERSIONI:
 Monofase: 220-277V / 50Hz.
 Trifase: 220-277V/ 50Hz o 380 – 480V /50Hz con protezione da sovraccarico a cura dell'utente.
- VERSIONI MONOFASI AUTOMATICHE CON GALLEGGIANTE.
- CAVO STANDARD:
 Monofase: H07RN-F 10mt completa di quadro elettrico con spezzone 0,7 metri senza spina.
 Trifase: H07RN-F 10mt senza spina.

SPECIALI VOLTAGGI E FREQUENZE A RICHIESTA.

DESIGN ENGINEERING:

- OIL BATH MOTOR (BIODEGRADABLE AND DIELECTRIC) FOR COOLING AND BEARING LUBRICATION.
- SEALING RING - ENGINE FACE.
- OIL BATH MECHANICAL SEALS.
- OIL BATH MECHANICAL SEALS.
- PERMISSIBLE DRAUGHT OF WATER: 5 m.
- IP 68 PROTECTION CLASS.
- CLASS "F" INSULATION.
- MAX. PUMPED LIQUID TEMPERATURE: 35°C.
- VERSIONS:
 Single Phase: 220-277V/50Hz.
 Three Phases: 220-277V/50Hz or 380-480V/50Hz with overload protection care of the User.
- AUTOMATIC SINGLE PHASE VERSIONS up to 1,1 kW.
- STANDARD CABLE FEATURES:
 Single Phase: H07RN-F 10mt complete with power supply box 0,7 m cable section, without connection plug.
 Three Phases: H07RN-F 10mt without connection plug.

CUSTOMISED VOLTAGE AND FREQUENCY RATING AVAILABLE ON DEMAND.

TABELLA MATERIALI / MATERIALS TABLE:

Pos.	Componente / Component	Materiale / Materials
A	Coperchio / Cover	GHISA (G20) / CAST IRON
B	Guarnizione / Gasket	GOMMA DIELETTRICA DIELECTRIC RUBBER
C	Carcassa motore / Motor housing	GHISA (G20) / CAST IRON
D	Albero (lato pompa) / Shaft (pump side)	ACCIAIO INOX AISI 304 DIN 1.4301 / STAINLESS STEEL
E	Tenuta meccanica / Mechanical seal	Lato Motore / Motor side DOPPIO ANELLO DI TENUTA NBR NBR DOUBLE SEALING RING
		Lato pompa / Pump side CARBURO DI SILICIO/ALLUMINA SILICON CARBIDE-ALUMINA
F	O-ring	NBR
G	Flangia inferiore / Upper flange	GHISA (G20) / CAST IRON
H	Girante / Impeller	
I	Piattello / Disk base	ACCIAIO / STEEL
M	Griglia / Greed	ACCIAIO INOX AISI 304 DIN 1.4301 / STAINLESS STEEL

TURBO L 200

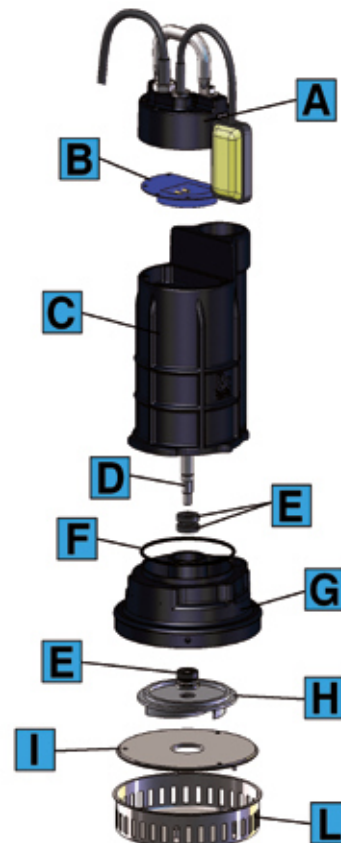

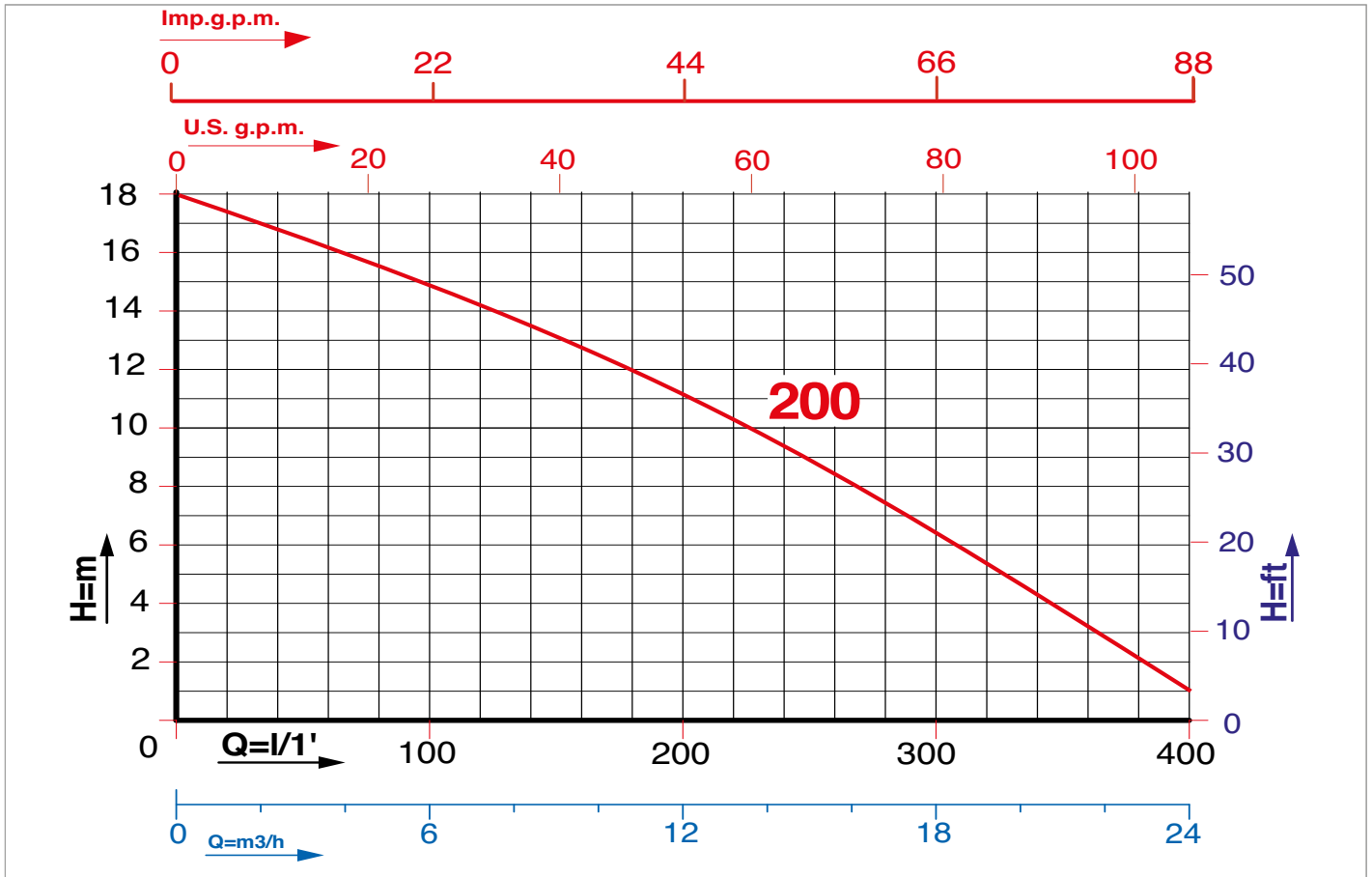

Caratteristiche di funzionamento a 2800 rpm 50Hz - Performances at 2800 rpm 50 Hz

Le prestazioni valgono per liquidi con densità $p = 1,0 \text{ kg/dm}^3$ ed una viscosità $v = 1 \text{ mm}^2/\text{s}$ / The performance data holds true for liquids with a $p = 1,0 \text{ kg/dm}^3$ density and a $v = 1 \text{ mm}^2/\text{s}$ viscosity.

MODELLO MODEL	VOLTAGGIO VOLTAGE	DATI ELETTRICI / ELECTRICAL DATA						DATI IDRAULICI / HYDRAULIC DATA							
		P1max	P2 nom.		I max	Condensatore Capacitor		m ³ /h	0	3	6	12	15	18	24
	50 Hz	kW	kW	HP	Ampere	µF	VC	l/min.	0	50	100	200	250	300	400
TURBO L 200 M	1 x 220-230V	2,7	1,5	2,0	12,5	40	450	H (m)	18,0	16,5	15,0	11,0	9,0	6,5	0,5
TURBO L 200 T	3 x 380-400V	2,7	1,5	2,0	12,5	---	---	H (m)	18,0	16,5	15,0	11,0	9,0	6,5	0,5

PRESSIONI TOTALI IN METRI COLONNA D'ACQUA
 TOTAL PUMP HEAD AND WATER COLUMN
 FEET/ft.

DIMENSIONI e PESI / SIZE AND WEIGHT DATA:

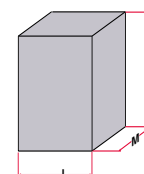
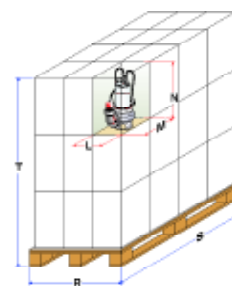
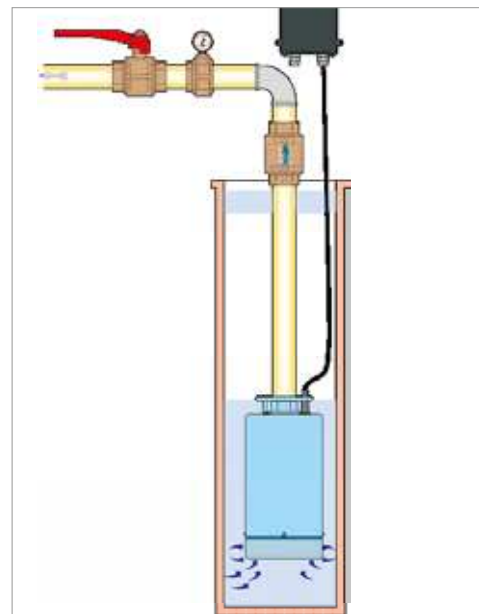
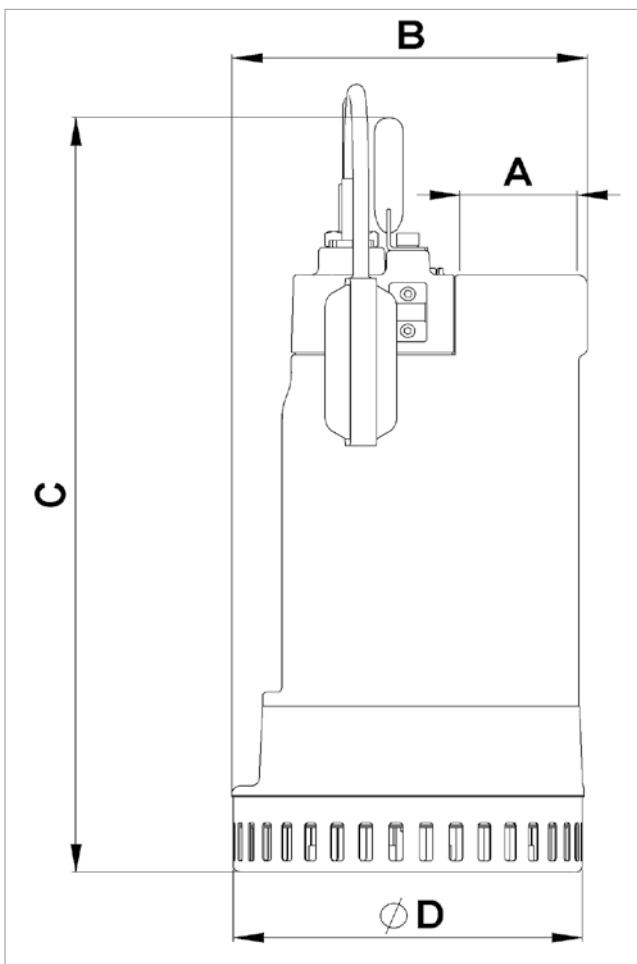

MODELLO / MODEL	DIMENSIONI POMPA in mm. / PUMP DIMENSIONS in mm.			
	A	B	C	D
TURBO L 200	2"	204	472	202

MODELLO / MODEL	DIMENSIONI SCATOLA / PACKING DIMENSIONS				DIMENSIONI PALLET / PALLET DIMENSIONS				
	L	M	N	Peso / Weight	R	S	T	nr.	Peso / Weight
	mm.	mm.	mm.	Kg.	mm.	mm.	mm.	scatole/cartons	Kg.
TURBO L 200	550	260	370	39,0	800	1200	2370	24	965

POMPE SOMMERSIBILI IN GHISA
SUBMERSIBLE PUMPS IN CAST IRON

TURBO LG 250-350



ELETTROPOMPE SOMMERSIBILI DRENAGGIO PER CANTIERISTICA SUBMERSIBLE ELECTRIC PUMPS FOR CONSTRUCTION WORK SITE DRAINAGE

PREVALENZA : 19,0 ÷ 23,0 mt.
PORTATA : 27 ÷ 30 m³/h
POTENZA NOMINALE : 1,8 kW (2,5HP) ÷ 2,6 kW (3,5HP)

PUMP HEAD : 19,0 mt ÷ 23,0 mt
DELIVERY : 27,0 m³/h ÷ 30,0 m³/h
RATED HORSEPOWER : 1,8 kW (2,5HP) ÷ 2,6 kW (3,5HP)

APPLICAZIONI

- DRENAGGIO DI CANTIERI EDILI E DI CUNICOLI.
- MOVIMENTAZIONE DI ACQUE MODERATAMENTE CARICHE CONTENENTI MATERIALI ANCHE ABRASIVI, IMPIANTI DI IRRIGAZIONE, ACQUE PIOVANE E DI FALDA.

APPLICATIONS

- WORK SITE, TRENCH DUCTS AND UNDERGROUND PASSAGE PUMP OUT
- HANDLING OF MODERATELY FOUL WATER WITH MATERIAL AND/OR ABRASIVE MATERIAL CONTENTS.



ARVEN[®]
WATER ■ PUMPS

CARATTERISTICHE DI COSTRUZIONE:

- MOTORE A BAGNO D'OLIO (BIODEGRADABILE E DIELETTRICO) PER RAFFREDDAMENTO E LUBRIFICAZIONE CUSCINETTI.
- DOPPIA TENUTA MECCANICA: LATO MOTORE A BAGNO D'OLIO. LATO POMPA A BAGNO D'ACQUA.
- IMMERSIONE MASSIMA: mt. 10.
- GRADO DI PROTEZIONE IP 68 .
- CLASSE DI ISOLAMENTO: F.
- TEMPERATURA MAX. LIQUIDO POMPATO: 35°C.
- PASSAGGIO LIBERO: 10mm.
- VERSIONI:
 Monofase: 220-277V / 50Hz con protettore termico incorporato.
 Trifase: 380-400V/ 50Hz con protezione da sovraccarico a cura dell'utente.
- CAVO STANDARD:
 Monofase: H05VV-F 10mt completa di quadro elettrico con spezzone 0,7 metri senza spina.
 Trifase: H05VV-F 10mt senza spina.

SPECIALE VOLTAGGIO E FREQUENZE A RICHIESTA.

DESIGN ENGINEERING:

- OIL BATH MOTOR (BIODEGRADABLE AND DIELECTRIC) FOR COOLING AND BEARING LUBRICATION.
- DOUBLE MECHANICAL SEALS: ENGINE FACE: OIL BATH. PUMP FACE: WATER BATH.
- PERMISSIBLE EIGHT OF WATER: 10 m.
- IP 68 PROTECTION CLASS.
- CLASS "F" INSULATION.
- BY PASS SECTION: 10mm.
- MAX. PUMPED LIQUID TEMPERATURE: 35°C.
- VERSIONS:
 Single Phase: 220-277V/50Hz with built in thermal protection.
 Three Phases: 380-400V/50Hz with overload protection care of the User.
- STANDARD CABLE FEATURES:
 Single Phase: H05VV-F 10mt complete with power supply box 0,7 m cable section, without connection plug.
 Three Phases: H05VV-F 10mt without connection plug.

CUSTOMIZE VOLTAGE AND FREQUENCY RATING AVAILABLE ON DEMAND.

TABELLA MATERIALI / MATERIALS TABLE:

Pos.	Componente / Component	Materiale / Materials	
A	Coperchio / Cover	GHISA (G20) / CAST IRON	
B	Guarnizione / Gasket	GOMMA DIELETTRICA DIELECTRIC RUBBER	
C	Carcassa motore / Motor housing	GHISA (G20) / CAST IRON	
D	Albero (lato pompa) / Shaft (pump side)	ACCIAIO INOX AISI 304 DIN 1.4301 / STAINLESS STEEL	
E	Tenuta meccanica / Mechanical seal	Lato Motore / Motor side	DOPPIO ANELLO DI TENUTA NBR NBR DOUBLE SEALING RING
		Lato pompa / Pump side	CARBURIO DI SILICIO/ALLUMINA SILICON CARBIDE-ALUMINA
F	O-ring	NBR	
G	Flangia inferiore / Upper flange	GHISA (GJS400)	
H	Girante / Impeller	CAST IRON WITH TREATMENT	
I	Diffusore / Diffuser	GHISA (G20) / CAST IRON	
L	Griglia / Greed	ACCIAIO INOX AISI 304 DIN 1.4301 / STAINLESS STEEL	

TURBO LG 250-350

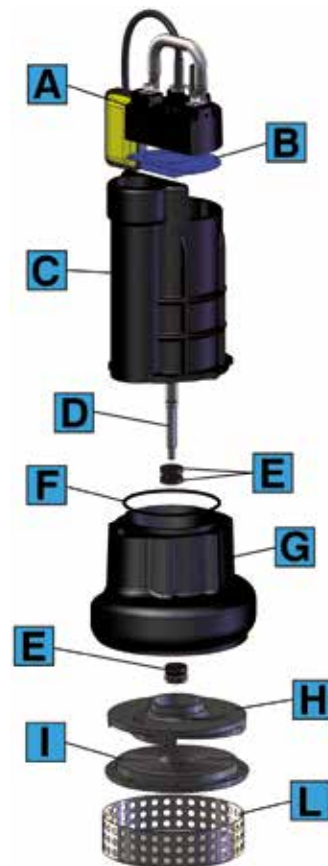

POMPE SOMMERSIBILI IN GHISA
SUBMERSIBLE PUMPS IN CAST IRON

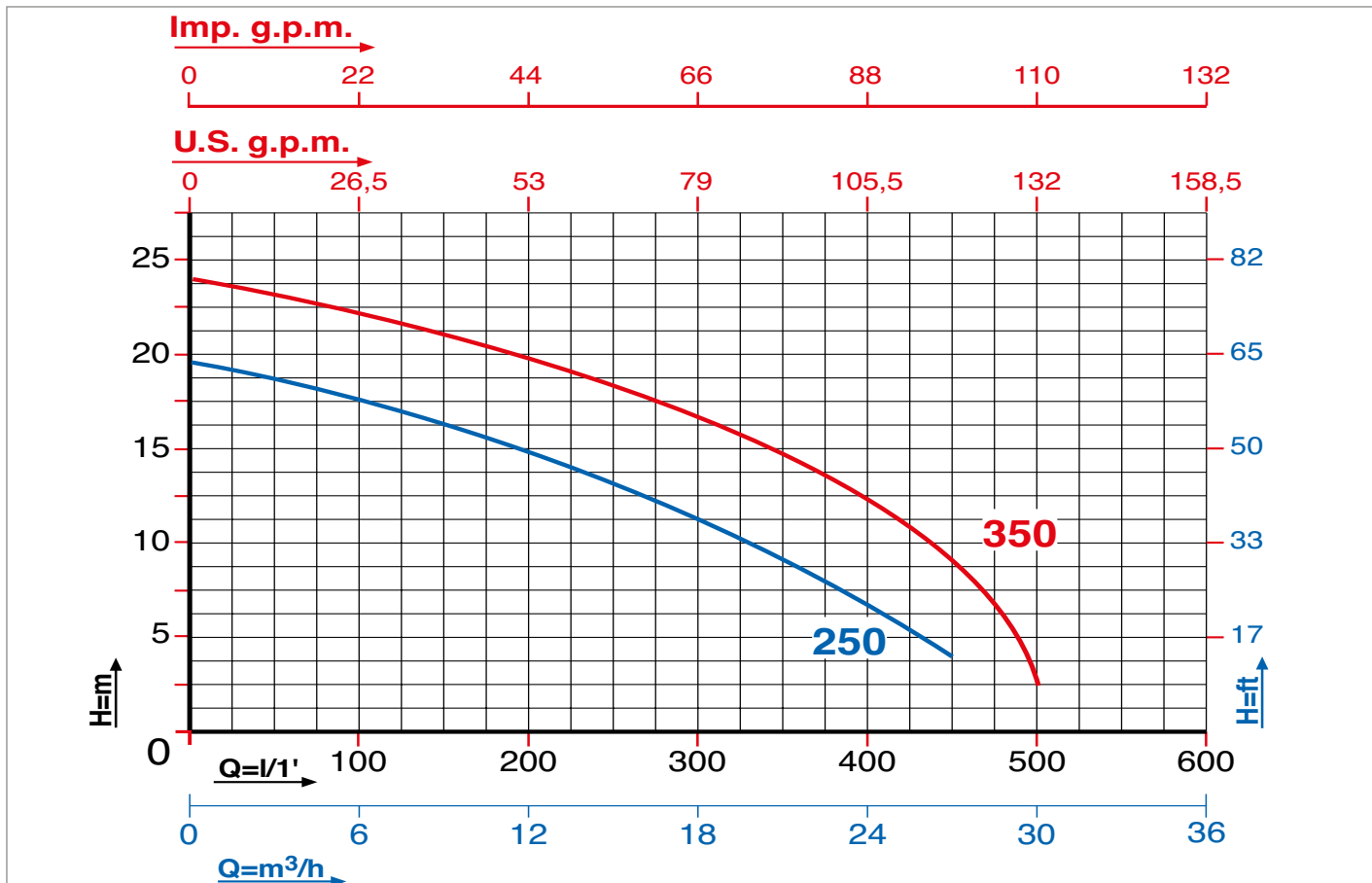

Caratteristiche di funzionamento a 2800 rpm 50Hz - Performances at 2800 rpm 50 Hz

Le prestazioni valgono per liquidi con densità $\rho = 1,0 \text{ kg/dm}^3$ ed una viscosità $\nu = 1 \text{ mm}^2/\text{s}$ / The performance data holds true for liquids with a $\rho = 1,0 \text{ kg/dm}^3$ density and a $\nu = 1 \text{ mm}^2/\text{s}$ viscosity.

MODELLO MODEL	VOLTAGGIO VOLTAGE 50 Hz	DATI ELETTRICI / ELECTRICAL DATA						DATI IDRAULICI / HYDRAULIC DATA															
		P1 max		P2 nom.		I max		Condensatore Capacitor		m³/h		H (m)											
		kW	kW	HP	Ampere	µF	VC	0	3	6	9	15	18	28,5	31,5								
TURBO LG 250 M	1 x 220-230V	3,2	1,8	2,5	13,5	40	450	0	50	100	150	250	300	475	525	19,0	18,5	17,5	16,0	13,0	11,0	2,5	---
TURBO LG 250 T	3 x 380-400V	3,0	1,8	2,5	4,5	---	---	0	50	100	150	250	300	475	525	19,0	18,5	17,5	16,0	13,0	11,0	2,5	---
TURBO LG 350 M	1 x 220-230V	4,2	2,6	3,5	16,5	50	450	0	50	100	150	250	300	475	525	24,0	23,0	22,0	21,0	18,0	16,5	6,0	2,5
TURBO LG 350 T	3 x 380-400V	4,0	2,6	3,5	6,0	---	---	0	50	100	150	250	300	475	525	24,0	23,0	22,0	21,0	18,0	16,5	6,0	2,5

PRESSIONE TOTALE METRO COLONNARE
 TOTAL PUMP HEAD AND WATER COLUMN HEIGHT (m)

DIMENSIONI e PESI / SIZE AND WEIGHT DATA:

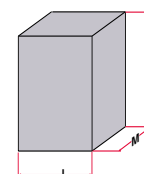
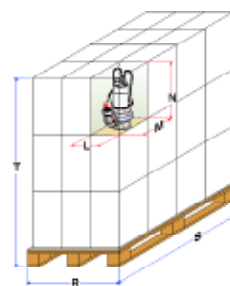
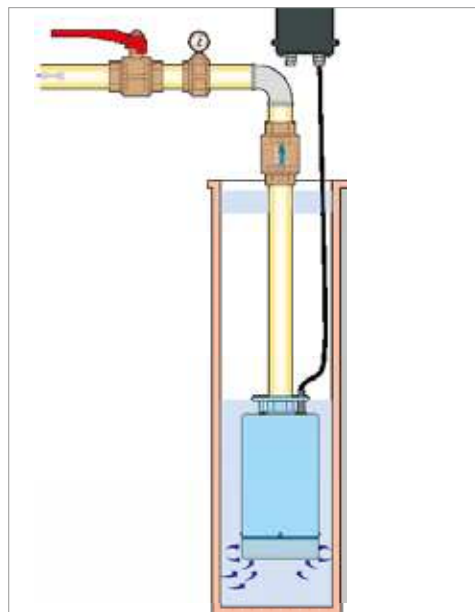
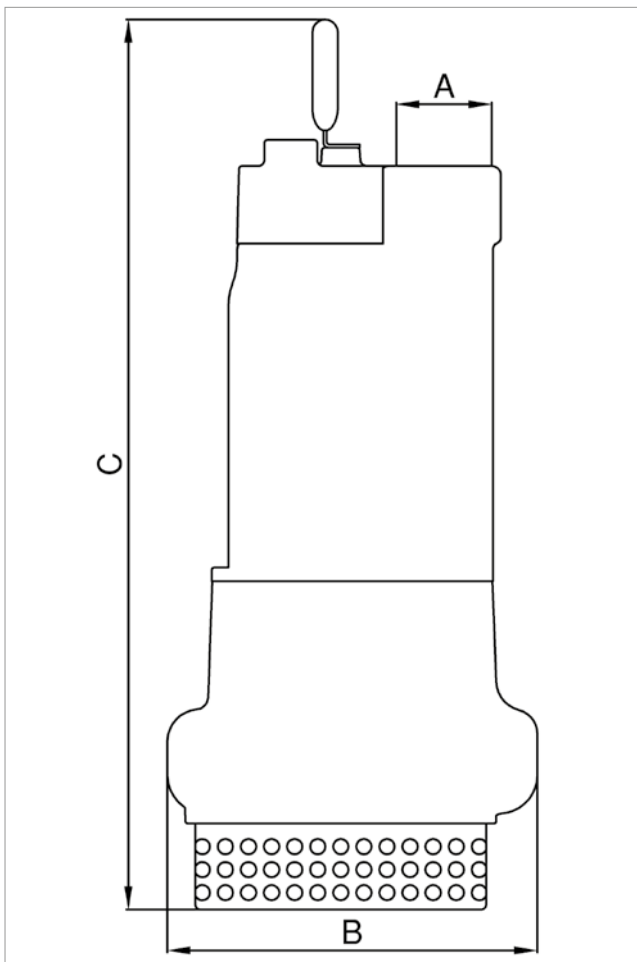

POMPE SOMMERSIBILI IN GHISA
SUBMERSIBLE PUMPS IN CAST IRON

MODELLO / MODEL	DIMENSIONI POMPA in mm. / PUMP DIMENSIONS in mm.		
	A	B	C
TURBO LG 250	2"	240	580
TURBO LG 350	2"	240	580

MODELLO / MODEL	DIMENSIONI SCATOLA / PACKING DIMENSIONS				DIMENSIONI PALLET / PALLET DIMENSIONS				
	L	M	N	Peso / Weight	R	S	T	nr.	Peso / Weight
	mm.	mm.	mm.	Kg.	mm.	mm.	mm.	scatole/cartons	Kg.
TURBO LG 250	600	260	370	45,0	800	1200	2060	28	1280
TURBO LG 350	600	260	370	45,0	800	1200	2060	28	1280

TURBO LG 500 ÷ 1500



ELETTROPOMPE SOMMERSIBILI DRENAGGIO PER CANTIERISTICA SUBMERSIBLE ELECTRIC PUMPS FOR COSTRUCTION WORK SITE DRAINAGE

PREVALENZA : 26,0 ÷ 50,0 mt.
PORTATA : 30,0 ÷ 138,0 m³/h
POTENZA NOMINALE : 3,7 kW (5HP) ÷ 15 kW (20HP)

PUMP HEAD : 26,0 mt ÷ 50,0 mt
DELIVERY : 30,0 m³/h ÷ 138,0 m³/h
RATED HORSEPOWER : 3,7 kW (5,0HP) ÷ 15 kW (20,0HP)

APPLICAZIONI

- DRENAGGIO DI CANTIERI EDILI E DI CUNICOLI.
- MOVIMENTAZIONE DI ACQUE MODERATAMENTE CARICHE CONTENENTI MATERIALI ANCHE ABRASIVI, IMPIANTI DI IRRIGAZIONE, ACQUE PIOVANE E DI FALDA.

APPLICATIONS

- WORK SITE, TRENCH DUCTS AND UNDERGROUND PASSAGE PUMP OUT
- HANDLING OF MODERATELY FOUL WATER WITH MATERIAL AND/OR ABRASIVE MATERIAL CONTENTS.

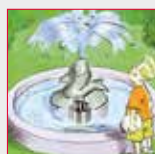

CARATTERISTICHE DI COSTRUZIONE:

- MOTORE A BAGNO D'OLIO (BIODEGRADABILE E DIELETTRICO) PER RAFFREDDAMENTO E LUBRIFICAZIONE CUSCINETTI.
- DOPPIA TENUTA MECCANICA: LATO MOTORE A BAGNO D'OLIO. LATO POMPA A BAGNO D'ACQUA.
- IMMERSIONE MASSIMA: mt. 10.
- GRADO DI PROTEZIONE IP 68 .
- CLASSE DI ISOLAMENTO: F.
- TEMPERATURA MAX. LIQUIDO POMPATO: 35°C.
- PASSAGGIO LIBERO: 10mm.
- VERSIONI:
Trifase: 380-400V/ 50Hz con protezione da sovraccarico a cura dell'utente.
- CAVO STANDARD:
Trifase: 10 mt H07RN-F senza spina.

SPECIALE VOLTAGGIO E FREQUENZE A RICHIESTA.

ACCESSORI DISPONIBILI A RICHIESTA:

- QUADRO ELETTRICO TRIFASE DI PROTEZIONE E COMANDO AUTOMATICO A MEZZO GALLEGGIANTE ELETTROMECCANICO.
- GALLEGGIANTE 10-20mt. DI CAVO.
- RACCORDI IN ALLUMINIO.
- RIDUZIONE DA 4" A 3" (TURBO-LG 1000 T).

DESIGN ENGINEERING:

- OIL BATH MOTOR (BIODEGRADABLE AND DIELECTRIC) FOR COOLING AND BEARING LUBRICATION.
- DOUBLE MECHANICAL SEALS: ENGINE FACE: OIL BATH. PUMP FACE: WATER BATH.
- PERMISSIBLE HEIGHT OF WATER: 10 m.
- IP 68 PROTECTION CLASS.
- CLASS "F" INSULATION.
- BY PASS SECTION: 10mm.
- MAX. PUMPED LIQUID TEMPERATURE: 35°C.
- VERSIONS:
Three Phases: 380-400V/50Hz with overload protection care of the User.
- STANDARD CABLE FEATURES:
Three Phases: 10 mt H07RN-F without connection plug.

CUSTOMIZE VOLTAGE AND FREQUENCY RATING AVAILABLE ON DEMAND.

ACCESSORIES AVAILABLE ON DEMAND:

- THREE PHASES ELECTRICAL SAFETY POWER SUPPLY BOX WITH AUTOMATIC ELECTROMECHANICAL FLOATER CONTROLS.
- FLOATER CONTROLS 10-20mt. ELECTRIC CABLE.
- ALUMINIUM CONNECTION PIECES .
- REDUCTION FROM 4" TO 3" (TURBO-LG 1000 T).

TABELLA MATERIALI / MATERIALS TABLE:

Pos.	Componente / Component	Materiale / Materials
A	Coperchio / Cover	GHISA (G20) / CAST IRON
B	Guarnizione / Gasket	TURBO-LG 500-550-750 GOMMA DIELETTRICA DIELECTRIC RUBBER
		TURBO-LG 1000 PLASTICA SPECIALE SPECIAL PLASTIC
C	Carcassa motore / Motor housing	GHISA (G20) / CAST IRON
D	Albero (lato pompa) / Shaft (pump side)	ACCIAIO INOX AISI 316 DIN 1.4401 / STAINLESS STEEL
E	Tenuta meccanica Mechanical seal	Lato Motore / Motor side CARBONE-ALLUMINA COAL - ALUMINA
		Lato pompa / Pump side CARBURO DI SILICIO SILICON CARBIDE
F	Flangia inferiore / Upper flange	GHISA (G25) / CAST IRON (G.25)
G	Girante / Impeller	GHISA (GJS400) CAST IRON (GJS400) WITH TREATMENT
H	Diffusore / Diffuser	ACCIAIO / STEEL
I	Griglia / Greed	
L	Piatto / Disk base	GHISA (G20) / CAST IRON
M	Prolunga / Extension	

TURBO LG 500-550-750

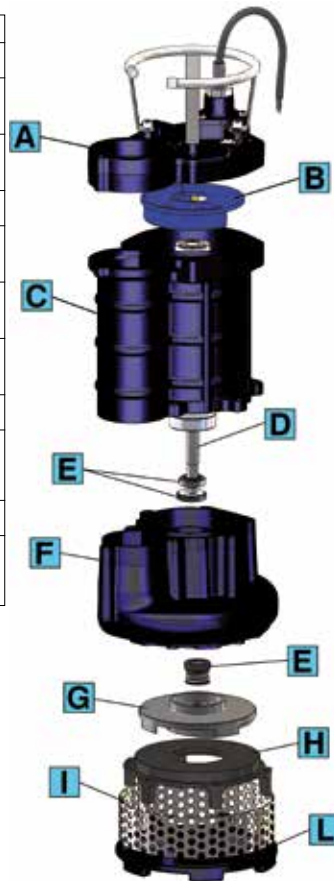

TURBO LG 1000

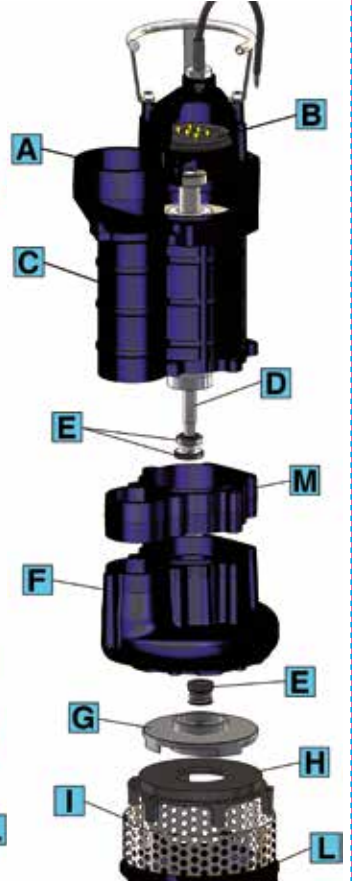

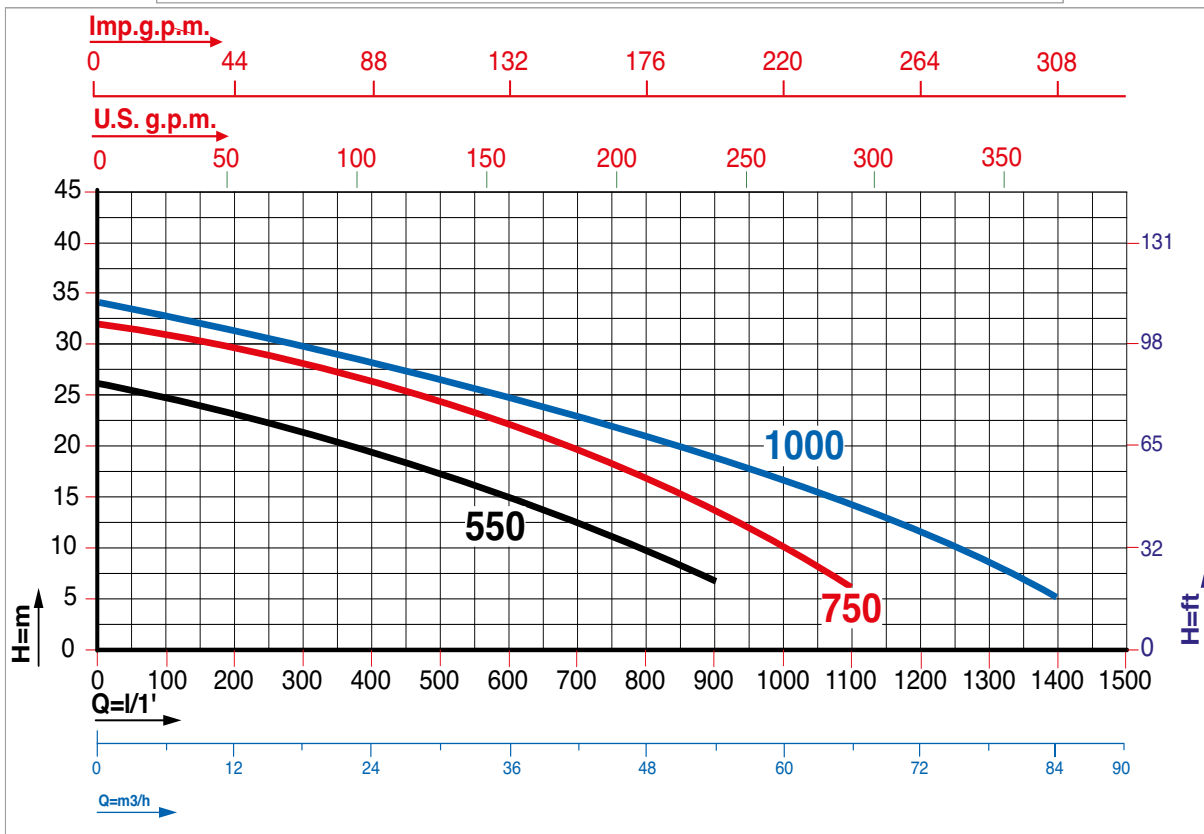
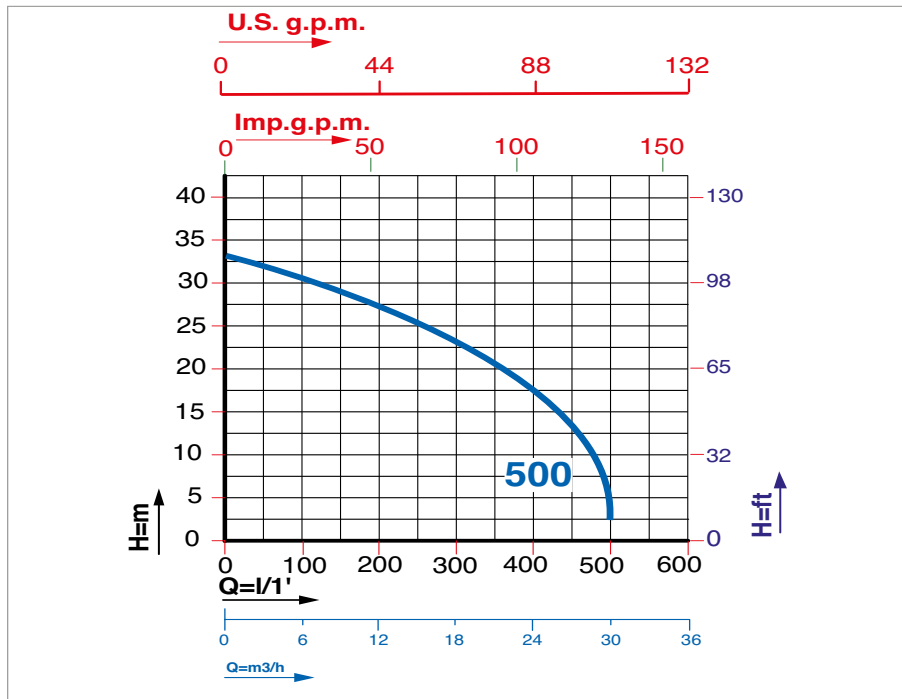

Caratteristiche di funzionamento a 2850 rpm 50Hz - Performances at 2850 rpm 50 Hz

Le prestazioni valgono per liquidi con densità $\rho = 1,0 \text{ kg/dm}^3$ ed una viscosità $\nu = 1 \text{ mm}^2/\text{s}$ / The performance data holds true for liquids with a $\rho = 1,0 \text{ kg/dm}^3$ density and a $\nu = 1 \text{ mm}^2/\text{s}$ viscosity.

MODELLO MODEL	VOLTAGGIO VOLTAGE 50 Hz	DATI ELETTRICI / ELECTRICAL DATA						DATI IDRAULICI / HYDRAULIC DATA								
		P1 max kW	P2 nom.		I max Ampere	Condensatore Capacitor		H (m)								
			kW	HP		μF	VC	0	6	18	30	54	66	84		
TURBO LG 500 T	3 x 380-400V	5,5	3,7	5,0	9,5	---	---	33,0	30,0	23,0	2,5	---	---	---	---	---
TURBO LG 550 T	3 x 380-400V	5,5	3,7	5,0	9,5	---	---	26,0	24,5	21,5	18,0	7,0	---	---	---	---
TURBO LG 750 T	3 x 380-400V	7,5	5,5	7,5	11,5	---	---	32,0	31,0	27,5	24,5	13,5	6,0	---	---	---
TURBO LG 1000 T	3 x 380-400V	7,5	7,5	10,0	12,5	---	---	34,0	32,5	29,5	27,0	18,5	14,5	5,0	---	---

PREVALENZA TOTALE METRI COLUMNA ACQUA
TOTAL PUMP HEAD AND WATER COLUMN HEIGHT (m)

CARATTERISTICHE DI COSTRUZIONE:

- MOTORE A BAGNO D'OLIO (BIODEGRADABILE E DIELETTRICO) PER RAFFREDDAMENTO E LUBRIFICAZIONE CUSCINETTI.
- DOPPIA TENUTA MECCANICA IN BAGNO D'OLIO
- IMMERSIONE MASSIMA: mt. 10.
- GRADO DI PROTEZIONE IP 68 .
- CLASSE DI ISOLAMENTO: F.
- TEMPERATURA MAX. LIQUIDO POMPATO: 35°C.
- PASSAGGIO LIBERO: 10mm.
- VERSIONI:
Trifase: 380-400V/ 50Hz con protezione da sovraccarico a cura dell'utente.
- CAVO STANDARD:
Trifase: 10 mt H07RN-F senza spina.

SPECIALE VOLTAGGIO E FREQUENZE A RICHIESTA.

ACCESSORI DISPONIBILI A RICHIESTA:

- QUADRO ELETTRICO TRIFASE DI PROTEZIONE E COMANDO AUTOMATICO A MEZZO GALLEGGIANTE ELETTROMECCANICO.
- GALLEGGIANTE 10-20mt. DI CAVO.
- RACCORDI IN ALLUMINIO.
- RIDUZIONE DA 4" A 3" (TURBO-LG 1000 T ÷ 1500 F).

DESIGN ENGINEERING:

- OIL BATH MOTOR (BIODEGRADABLE AND DIELECTRIC) FOR COOLING AND BEARING LUBRICATION.
- DOUBLE MECHANICAL SEALS IN OIL BATH.
- PERMISSIBLE HEIGHT OF WATER: 10 m.
- IP 68 PROTECTION CLASS.
- CLASS "F" INSULATION.
- BY PASS SECTION: 10mm.
- MAX. PUMPED LIQUID TEMPERATURE: 35°C.
- VERSIONS:
Three Phases: 380-400V/50Hz with overload protection care of the User.
- STANDARD CABLE FEATURES:
Three Phases: 10 mt H07RN-F without connection plug.

CUSTOMIZE VOLTAGE AND FREQUENCY RATING AVAILABLE ON DEMAND.

ACCESSORIES AVAILABLE ON DEMAND:

- THREE PHASES ELECTRICAL SAFETY POWER SUPPLY BOX WITH AUTOMATIC ELECTROMECHANICAL FLOATER CONTROLS.
- FLOATER CONTROLS 10-20mt. ELECTRIC CABLE.
- ALUMINIUM CONNECTION PIECES .
- RIDUCTION FROM 4" TO 3" (TURBO-LG 1000 T ÷ 1500 F).

POMPE SOMMERSIBILI IN GHISA
SUBMERSIBLE PUMPS IN CAST IRON

TABELLA MATERIALI / MATERIALS TABLE:

Pos.	Componente / Component	Materiale / Materials
A	Coperchio / Cover	GHISA (G20) / CAST IRON
B	Guarnizione / Gasket	PLASTICA SPECIALE SPECIAL PLASTIC
C	Carcassa motore / Motor housing	GHISA (G20) / CAST IRON
D	Albero (lato pompa) / Shaft (pump side)	ACCIAIO INOX AISI 316 DIN 1.4401 / STAINLESS STEEL
E	Tenuta meccanica Mechanical seal	Lato Motore / Motor side CARBURO DI SILICIO-CARBURO DI SILICIO SILICON CARBIDE-SILICON CARBIDE
		Lato pompa / Pump side GRAFITE-CERAMICA GRAPHITE-CERAMIC
F	Flangia inferiore / Upper flange	GHISA (G25) / CAST IRON (G.25)
G	Girante / Impeller	GHISA CON TRATTAMENTO CAST IRON WITH TREATMENT
H	Diffusore / Diffuser	
I	Griglia / Greed	ACCIAIO / STEEL
L	Piatto / Disk base	GHISA (G20) / CAST IRON
M	Prolunga / Extension	
N	Piattello tenuta / Mechanical seal plate	GHISA (G25) / CAST IRON

TURBO LG 750/F-1250/F-1500/F

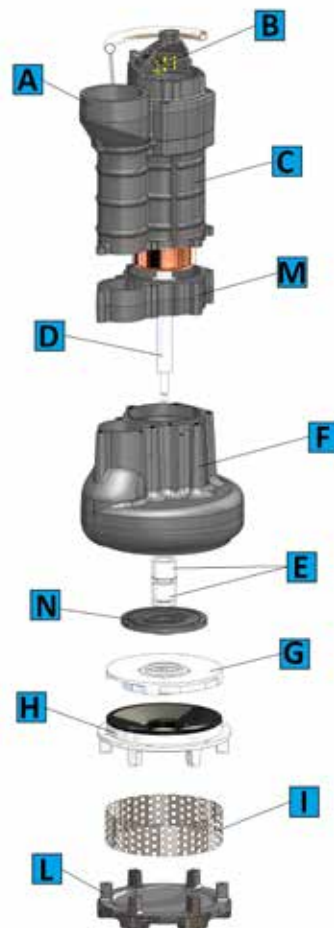

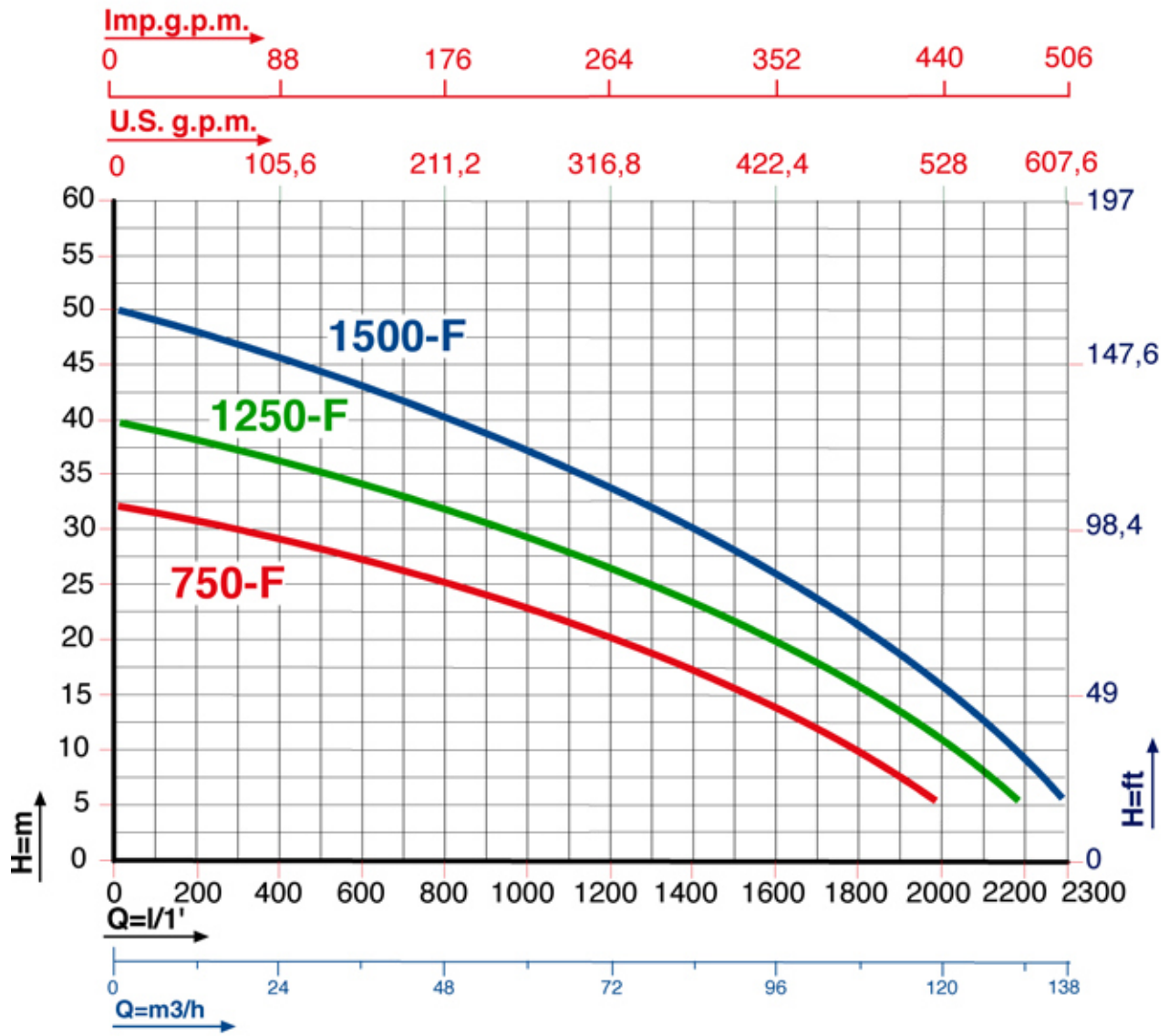

Caratteristiche di funzionamento a 2800 rpm 50Hz e 3450 rpm 60Hz - Performances at 2800 rpm 50 Hz and 3450 rpm 60 Hz Le prestazioni valgono per liquidi con densità $\rho = 1,0 \text{ kg/dm}^3$ ed una viscosità $\nu = 1 \text{ mm}^2/\text{s}$ /

MODELLO / MODEL	VOLTAGGIO VOLTAGE 50Hz	DATI ELETTRICI / ELECTRICAL DATA						DATI IDRAULICI / HYDRAULIC DATA										
		P1 max	P2 nom		I max	Condensatore- Capacitor		m ³ /h	H (m)									
			kW	kW		HP	Ampere		µF	VC	0	24	48	72	96	108	120	132
TURBO LG 750 F	3 x 380-400V	10,5	7,5	10	19	---	---	31	28	24	20	14	8	5	---	---		
TURBO LG 1250 F	3 x 380-400V	14	12,5	16,5	23	---	---	40	35	31	26,5	20	14	11	5	---		
TURBO LG 1500 F	3 x 380-400V	18,0	15	20	29	---	---	50	45	40	33	26	20	16	9	5		

PRELEVANZA TOTALE IN METRI COLONNA ACQUA
TOTAL PUMP HEAD AND WATER COLUMN HEIGHT IN m.

DIMENSIONI e PESI / SIZE AND WEIGHT DATA:

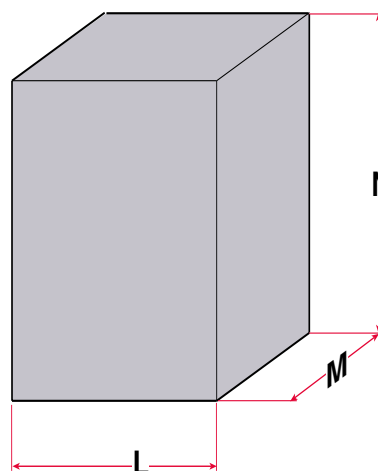
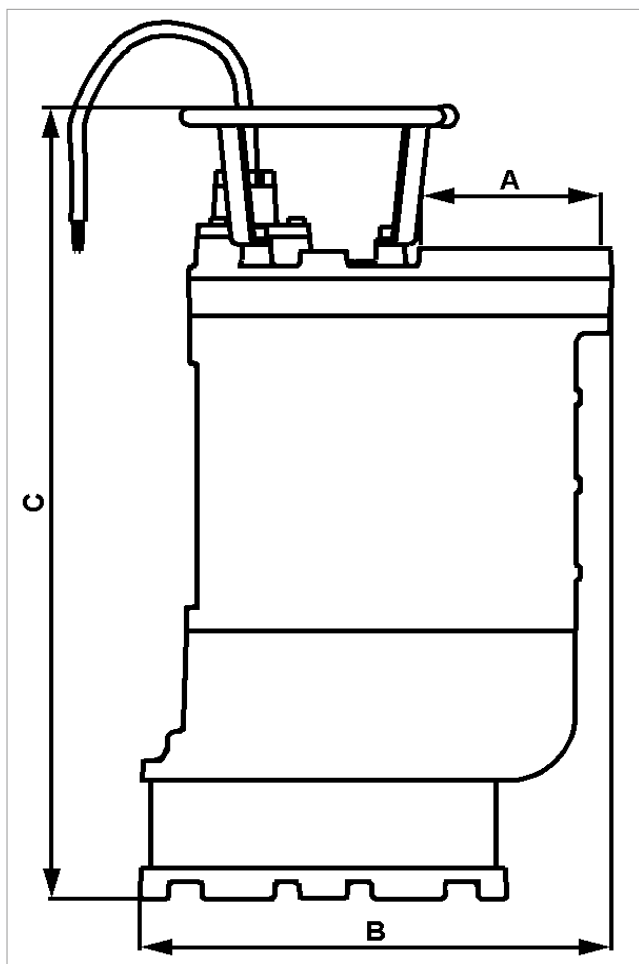

MODELLO / MODEL	DIMENSIONI POMPA in mm. / PUMP DIMENSIONS in mm.		
	A	B	C
TURBO-LG 500	3"	299	542.5
TURBO-LG 550	3"	299	542.5
TURBO-LG 750	3"	299	542.5
TURBO-LG 1000	4"	337	706
TURBO-LG 750 F	4"	350	780
TURBO-LG 1250 F	4"	350	780
TURBO-LG 1500 F	4"	350	780

MODELLO / MODEL	DIMENSIONI SCATOLA / PACKING DIMENSIONS				DIMENSIONI PALLET / PALLET DIMENSIONS				
	L mm.	M mm.	N mm.	Peso/weight Kg	R mm.	S mm.	T mm.	nr. wooden case	Peso/weight Kg
TURBO-LG 500	715	395	370	60	715	790	2200	12	740
TURBO-LG 550	715	395	370	60	715	790	2200	12	740
TURBO-LG 750	715	395	370	62	715	790	2200	12	764
TURBO-LG 1000	700	800	330	90	700	800	2200	6	560
TURBO-LG 750 F	400	450	1000	102	910	1030	2200	8	928
TURBO-LG 1250 F	400	450	1000	108	910	1030	2200	8	976
TURBO-LG 1500 F	400	450	1000	110	910	1030	2200	8	992

TURBO TC 200 - 300 - 400



ELETTROPOMPE SOMMERSIBILI BICANALI PER ACQUE CARICHE **SUBMERSIBLE TWIN-CHANNEL ELECTRIC PUMPS FOR WASTEWATER**

PREVALENZA : 16,0 ÷ 19,0 mt.
PORTATA : 30 ÷ 39 m³/h
POTENZA NOMINALE : 1,5 kW (2,0HP) ÷ 2,25 kW (4,0HP)

PUMP HEAD : 16,0 mt ÷ 19,0 mt
DELIVERY : 30,0 m³/h ÷ 39,0 m³/h
RATED HORSEPOWER : 1,5 kW (2,0HP) ÷ 2,25 kW (4,0HP)

APPLICAZIONI

- SVUOTAMENTO DI FOSSE DI DECANTAZIONE, POZZI NERI, POZZI DI RACCOLTA LIQUAMI.
- POMPAGGIO DI ACQUE LURIDE ANCHE CON CORPI SOLIDI IN SOSPENSIONE.
- MOVIMENTAZIONE DI ACQUE LURIDE AD USO DOMESTICO ED INDUSTRIALE.

APPLICATIONS

- DECANTATION PIT, SEWAGE PIT AND SLURRY COLLECTION PIT PUMP OUT.
- PUMP OUT OF LAVATORY/FOUL WATER WITH POSSIBLE FLOATING SOLIDS CONTENTS.
- DOMESTIC AND INDUSTRIAL LAVATORY/BLACK WATER HANDLING SYSTEMS.



ARVEN[®]
WATER ■ PUMPS

CARATTERISTICHE DI COSTRUZIONE:

- MOTORE A BAGNO D'OLIO (BIODEGRADABILE E DIELETTRICO) PER RAFFREDDAMENTO E LUBRIFICAZIONE CUSCINETTI.
- DOPPIA TENUTA MECCANICA: LATO MOTORE A BAGNO D'OLIO, LATO POMPA A BAGNO D'ACQUA.
- IMMERSIONE MASSIMA: mt. 10.
- GRADO DI PROTEZIONE IP 68 .
- CLASSE DI ISOLAMENTO: F.
- TEMPERATURA MAX. LIQUIDO POMPATO: 35°C.
- PASSAGGIO LIBERO: 25mm.
- VERSIONI:
Trifase: 380-400V/ 50Hz con protezione da sovraccarico a cura dell'utente.
- CAVO STANDARD:
Trifase: 10 mt H07RN-F senza spina.

SPECIALE VOLTAGGIO E FREQUENZE A RICHIESTA.

DESIGN ENGINEERING:

- OIL BATH MOTOR (BIODEGRADABLE AND DIELECTRIC) FOR COOLING AND BEARING LUBRICATION.
- DOUBLE MECHANICAL SEALS: ENGINE FACE: OIL BATH, PUMP FACE: WATER BATH.
- PERMISSIBLE EIGHT OF WATER: 10 m.
- IP 68 PROTECTION CLASS.
- CLASS "F" INSULATION.
- MAX. PUMPED LIQUID TEMPERATURE: 35°C.
- BY PASS SECTION: 25mm.
- VERSIONS:
Three Phases: 380-400V/50Hz with overload protection care of the User.
- STANDARD CABLE FEATURES:
Three Phases: 10 mt H07RN-F without connection plug.

CUSTOMIZE VOLTAGE AND FREQUENCY RATING AVAILABLE ON DEMAND.

TABELLA MATERIALI / MATERIALS TABLE:

Pos.	Componente / Component	Materiale / Materials	
A	Coperchio / Cover	GHISA (G20) / CAST IRON	
B	Guarnizione / Gasket	GOMMA / RUBBER NBR 70	
C	Carcassa motore / Motor housing	GHISA (G20) / CAST IRON	
D	Albero / Shaft	ACCIAIO INOX AISI 416 DIN 1.4005 / STAINLESS STEEL	
E	Tenuta meccanica / Mechanical seal	Lato Motore / Motor side	DOPPIO ANELLO DI TENUTA NBR / NBR DOUBLE SEALING RING
		Lato pompa / Pump side	CARBURO DI SILICIO/ALLUMINA / SILICON CARBIDE-ALUMINA
F	O-ring	NBR	
G	Flangia inferiore / Upper flange	GHISA (G25) / CAST IRON	
H	Girante / Impeller	GHISA (G20) / CAST IRON	
I	Diffusore / Diffuser		
L	Piattello / Disk base	ACCIAIO INOX AISI 304 DIN 1.4301 / STAINLESS STEEL	

TURBO TC 200-300-400

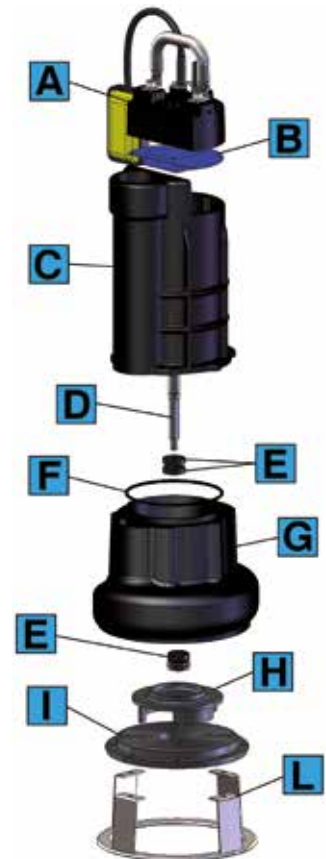

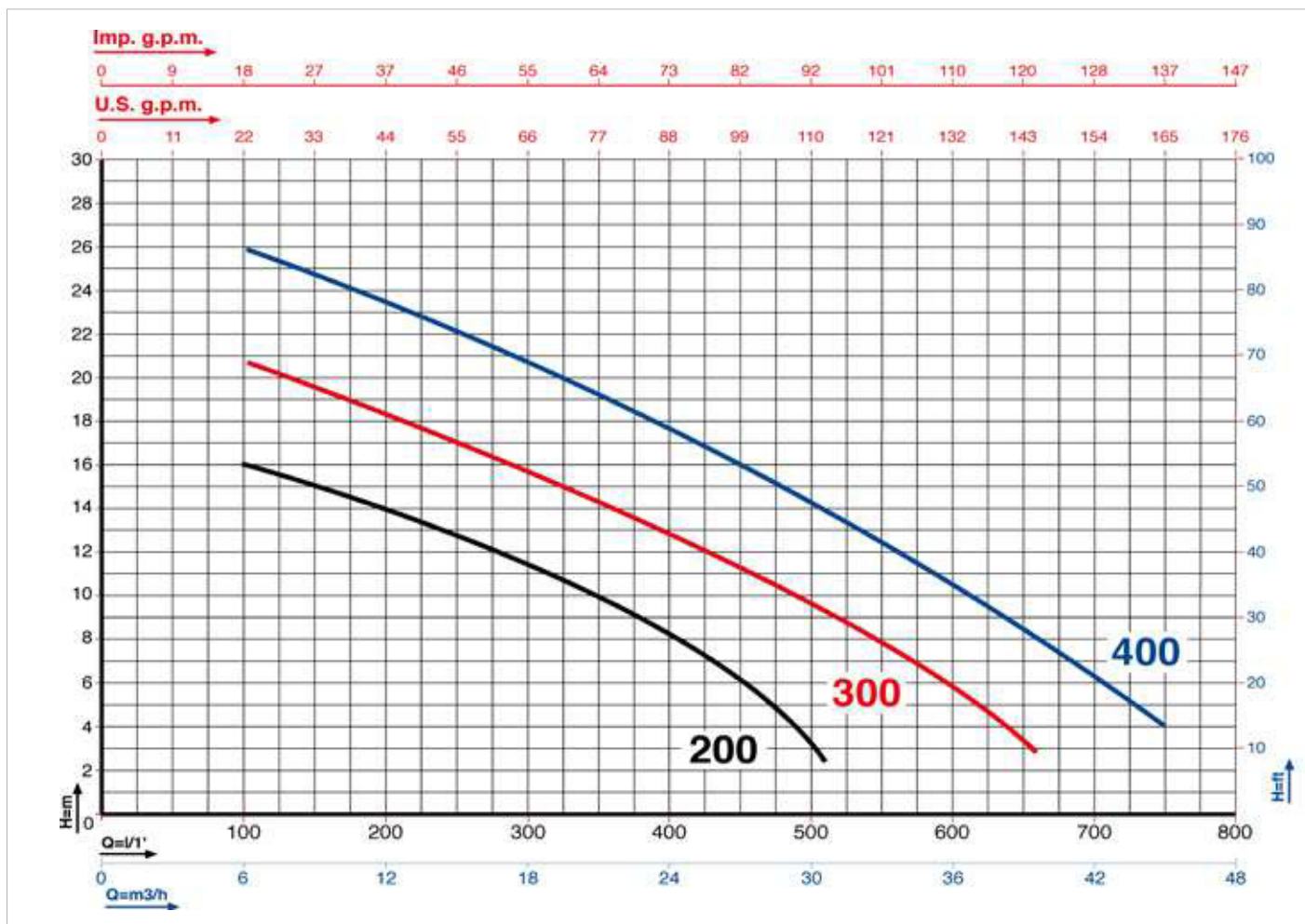

Caratteristiche di funzionamento a 2850 rpm 50Hz - Performances at 2850 rpm 50 Hz

Le prestazioni valgono per liquidi con densità $\rho = 1,0 \text{ kg/dm}^3$ ed una viscosità $\nu = 1 \text{ mm}^2/\text{s}$ / The performance data holds true for liquids with a $\rho = 1,0 \text{ kg/dm}^3$ density and a $\nu = 1 \text{ mm}^2/\text{s}$ viscosity.

MODELLO MODEL	VOLTAGGIO VOLTAGE 50 Hz	DATI ELETTRICI / ELECTRICAL DATA						DATI IDRAULICI / HYDRAULIC DATA									
		P1 max		P2 nom.		I max	Condensatore Capacitor		m³/h	6	9	15	18	24	27	30	39
		kW	kW	HP	Ampere	µF	VC	l/min.	100	150	250	300	400	450	500	650	750
TURBO TC 200 M	1 x 220-230V	3,0	1,5	2,0	13,5	40	450	H (m)	16,0	15,0	12,5	11,0	8,0	5,5	1,0	---	---
TURBO TC 200 T	3 x 380-400V	2,3	1,5	2,0	4,0	---	---		16,0	15,0	12,5	11,0	8,0	5,5	1,0	---	---
TURBO TC 300 M	1 x 220-230V	3,5	2,25	3,0	15,0	50	450		19,0	17,5	15,5	14,5	11,5	10,0	8,0	1,0	---
TURBO TC 300 T	3 x 380-400V	3,3	2,25	3,0	6,0	---	---		19,0	17,5	15,5	14,5	11,5	10,0	8,0	1,0	---
TURBO TC 400 T	3 x 380-400V	5,5	3,0	4,0	9,1	---	---		26,0	24,5	22,0	20,5	17,5	16,0	14,0	8,5	4,0

PREVALENZA TOTALE in METRI COLONNA ACQUA / TOTAL PUMP HEAD AND WATER COLUMN HEIGHT IN m.

DIMENSIONI e PESI / SIZE AND WEIGHT DATA:

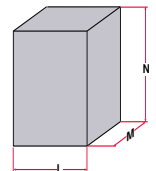
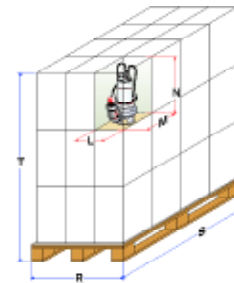
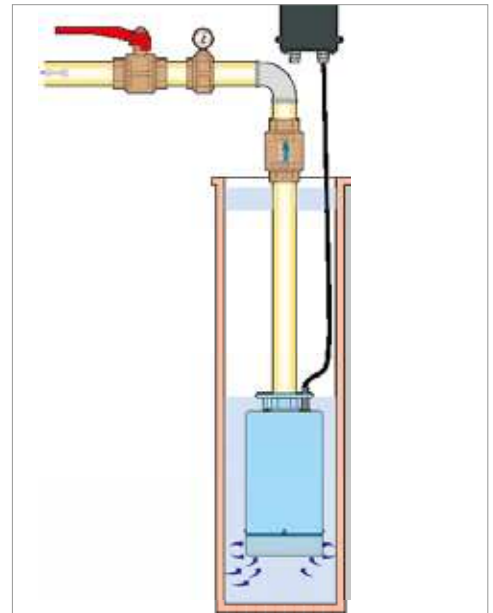
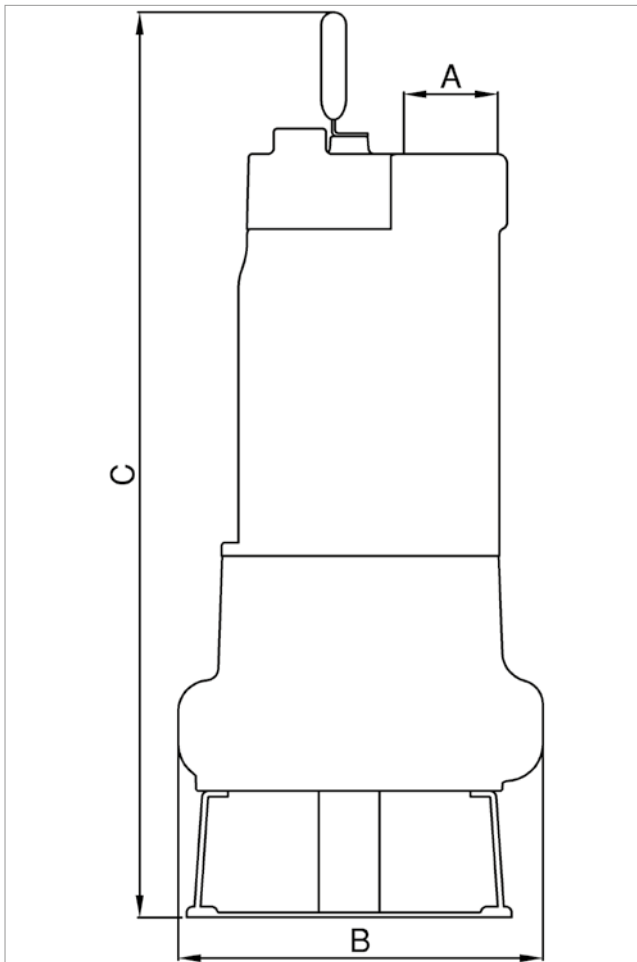

MODELLO / MODEL	DIMENSIONI POMPA in mm. / PUMP DIMENSIONS in mm.		
	A	B	C
TURBO TC 200	2"	240	618
TURBO TC 300	2"	240	618
TURBO TC 400	2"	240	618

MODELLO / MODEL	DIMENSIONI SCATOLA / PACKING DIMENSIONS				DIMENSIONI PALLET / PALLET DIMENSIONS				
	L	M	N	Peso / Weight	R	S	T	nr.	Peso / Weight
	mm.	mm.	mm.	Kg.	mm.	mm.	mm.	scatole/cartons	Kg.
TURBO TC 200	640	260	370	45,0	800	1200	2060	21	970
TURBO TC 300	640	260	370	45,0	800	1200	2060	21	970
TURBO TC 400	640	260	370	46,0	800	1200	2060	21	991

TURBO J



ELETTROPOMPE PERIFERICHE SOMMERSE PER POZZI DA 4'' **PERIPHERAL SUBMERSED ELECTRIC PUMPS FOR 4'' WELLS**

PREVALENZA : 76,0 mt ÷ 130,0 mt
PORTATA : 2,4 m³/h ÷ 4,2 m³/h
POTENZA NOMINALE : 0,75 kW (1,0HP) ÷ 1,1 kW (1,5HP)

PUMP HEAD : 76,0 mt ÷ 130,0 mt
DELIVERY : 2,4 m³/h ÷ 4,2 m³/h
RATED HORSEPOWER : 0,75 kW (1,0HP) ÷ 1,1 kW (1,5HP)

APPLICAZIONI

- PRESSURIZZAZIONE DI IMPIANTI DOMESTICI E PICCOLA IRRIGAZIONE
- MOVIMENTAZIONE DI LIQUIDI NON AGGRESSIVI PER USI CIVILI ED INDUSTRIALI IMPIANTI DI LAVAGGIO, INSERIMENTO SU MACCHINARI PIU' COMPLESSI PER USI INDUSTRIALI

APPLICAZIONI

- FOR DOMESTIC SYSTEMS AND SMALL IRRIGATION SYSTEM PRESSURISATION.
- HANDLING OF NON AGGRESSIVE CIVIL AND INDUSTRIAL LIQUIDS FOR WASHING SYSTEMS AND FOR INSERTION INTO COMPLEX INDUSTRIAL MACHINERY AND LINES.



CARATTERISTICHE DI COSTRUZIONE:

- MOTORE RAFFREDDATO IN BAGNO DI LIQUIDO REFRIGERANTE ATOSSICO.
- VALVOLA DI RITEGNO INCORPORATA.
- DOPPIA TENUTA MECCANICA ROTANTE.
- MEMBRANA DI COMPENSAZIONE IN GOMMA ANTIOLIO.
- GRADO DI PROTEZIONE IP 68.
- CLASSE DI ISOLAMENTO: F
- TEMPERATURA MAX.LIQUIDO POMPATO: 35°C.
- VERSIONI: Monofase: 220 - 230V/50Hz o 220 - 230V/60Hz con protettore termico incorporato.
- POTENZA MOTORE: da 1,0 Hp a 1,5Hp solo VERSIONE MONOFASE.
- CAVO STANDARD:
Monofase:10 metri H05VV-F

GHISA CON TRATTAMENTO CATAFORESI

SPECIALI VOLTAGGI E FREQUENZE A RICHIESTA.

ACCESSORI A RICHIESTA:

- QUADRO ELETTRICO COMPLETO DI CONDENSATORE ED INTERRUTTORE

DESIGN ENGINEERING:

- ATOXIC OIL-COOLED MOTOR WITH COMPENSATION MEMBRANE.
- BULIT-IN NON-RETURN VALVE.
- OIL-PROOF RUBBER COMPENSTION MEMBRANE
- ROTATING DOUBLE MECHANICAL SEAL
- IP 68 PROTECTION CLASS.
- CLASS "F" INSULATION
- MAX. PUMPED LIQUID TEMPERATURE: 35°C.
- VERSIONS: Single Phase: 220 - 230 V/50 Hz or 220 - 230V/60 Hz with built in thermal protection.
- MOTOR POWER: from 1,0 Hp to 1,5Hp only single phase versions.
- STANDARD CABLE FEATURES:
single phase 10 metres H05VV-F

CAST IRON PARTS WITH CATAPHORESIS TREATMENT

CUSTOMISED VOLTAGE AND FREQUENCY RATING AVAILABLE ON DEMAND.

ACCESSORIES ON DEMAND:

- CONTROL BOX WHIT CAPACITOR AND SWITCH

TABELLA MATERIALI - MATERIALS TABLE:

Pos.	Componente - Component	Materiale - Materials
A	Testate / Heads	GHISA (G.20) / CAST IRON
B	Girante / Impeller	OTTONE / BRASS
C	Flangia / Flange	GHISA (G.20) / CAST IRON
D	Albero (lato pompa) / Shaft (pump side)	ACCIAIO INOX AISI416-DIN 1.4005 / STAINLESS STEEL
E	Carcassa esterna / External motor housing	ACCIAIO INOX AISI304-DIN 1.4301 / STAINLESS STEEL
F	Supporto / Support	ALLUMINIO ALUMINUM
G	Membrana	NBR
H	Piattello / Plate	ACCIAIO INOX AISI304-DIN 1.4301 / STAINLESS STEEL
I	Base / Base	TECNOPLIMERO TECNOPOLYMER

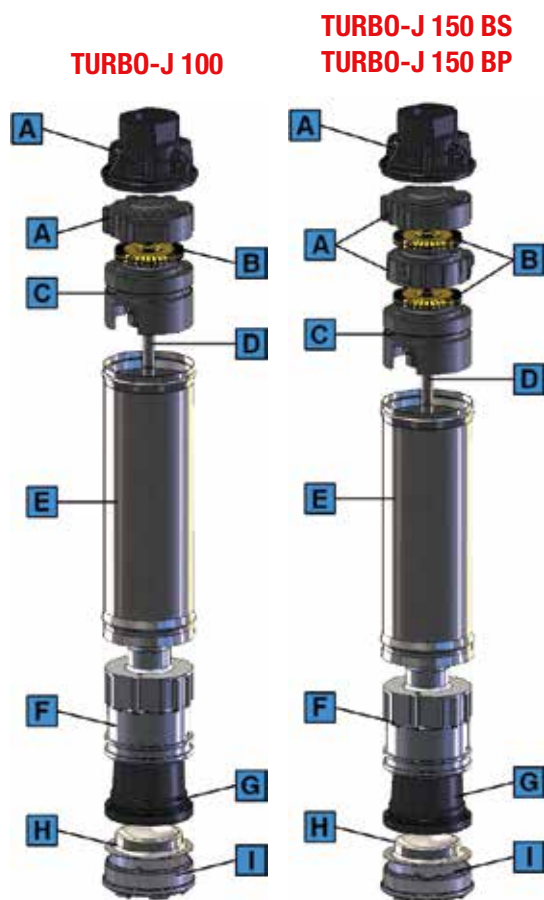

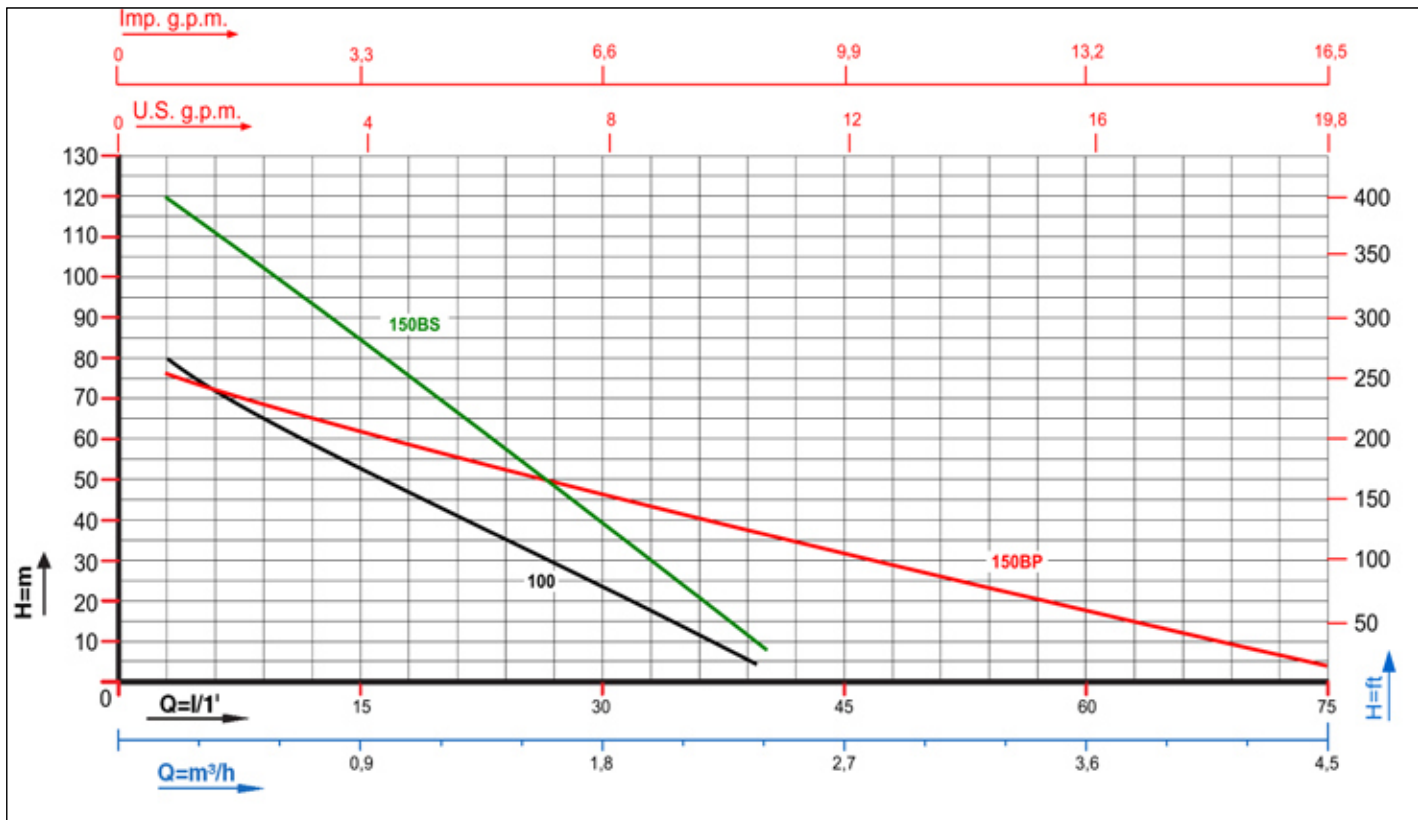

Caratteristiche di funzionamento a 2800 rpm 50Hz e 3450 rpm 60Hz - Performances at 2800 rpm 50 Hz and 3450 rpm 60 Hz

Le prestazioni valgono per liquidi con densità $p = 1,0 \text{ kg/dm}^3$ ed una viscosità $v = 1 \text{ mm}^2/\text{s}$ / The performance data holds true for liquids with a $p = 1,0 \text{ kg/dm}^3$ density and a $v = 1 \text{ mm}^2/\text{s}$ viscosity.

MODELLO MODEL	VOLTAGGIO VOLTAGE 50 HZ	DATI ELETTRICI / ELECTRICAL DATA						DATI IDRAULICI / HYDRAULIC DATA										
		P1 max		P2 nom.		I max	Condensatore Capacitor µF VC	m³/h	0,3	0,9	1,2	1,5	1,8	2,1	2,4	3,0	3,6	4,2
		kW	kW	HP	Ampere	l/min.		5	15	20	25	30	35	40	50	60	70	
TURBO-J 100 M	1 X 220-230 V	1,3	0,75	1,0	9,0	40,0	450	H (m)	74,0	52,0	43,0	33,0	25,0	12,0	3,0	---	---	---
TURBO-J 150BS M	1 X 220-230 V	2,7	1,1	1,5	13,5	50,0	450		115,0	84,0	70,0	52,0	40,0	21,0	7,0	---	---	---
TURBO-J 150BP M	1 X 220-230 V	2,7	1,1	1,5	13,5	50,0	450		71,0	61,0	56,0	51,0	45,0	40,0	35,0	25,0	15,0	5,0

PRELEVANZA TOTALE IN METRI COLONNA ACQUA
TOTAL PUMP HEAD AND WATER COLUMN HEIGHT IN m.

DIMENSIONI e PESI/SIZE AND WEIGHT DATA :

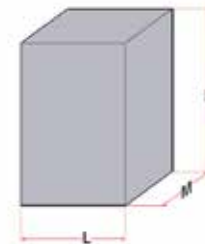
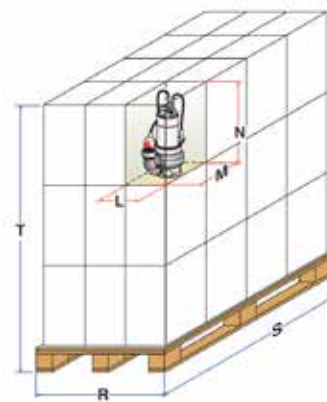
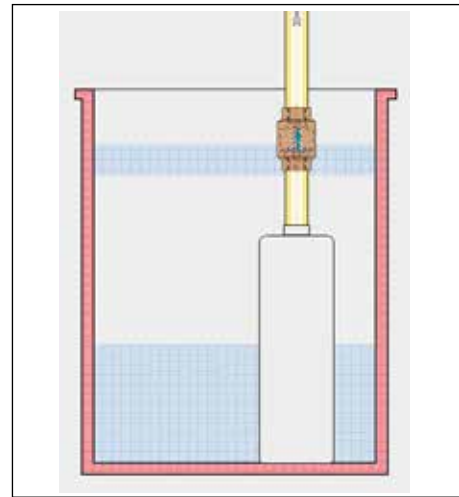
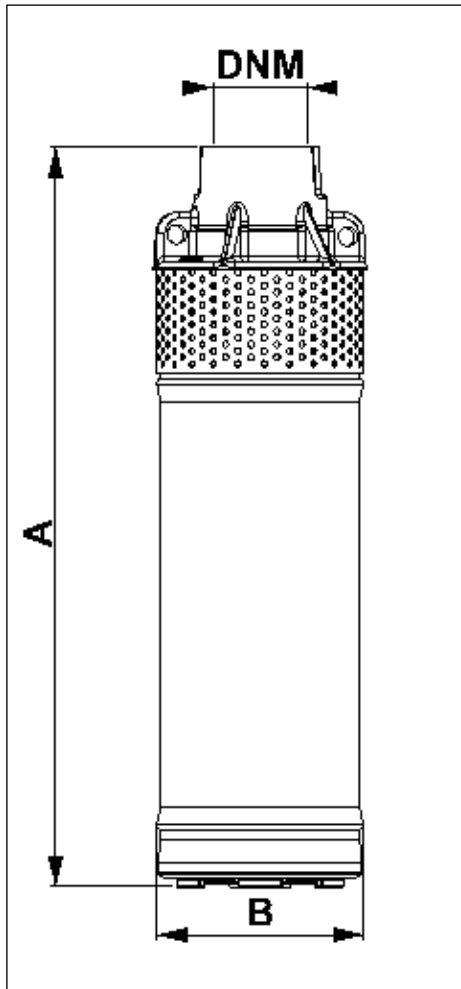

MODELLO MODEL	DIMENSIONI in mm. / PUMP DIMENSION IN mm.		
	DNM	A	B
TURBO-J 100	1" 1/4	488	96
RED.TURBO-J150 BS	1" 1/4	511	96
RED.TURBO-J150 BP	1" 1/4	511	96

MODELLO MODEL	DIMENSIONI SCATOLA / PACKING DIMENSIONS				DIMENSIONI PALLET / PALLET DIMENSIONS				
	L mm	M mm	N mm	PESO/Weight kg	R mm	S mm	T mm	nr. scatole/cartons	PESO/Weight kg
TURBO-J 100	240	660	220	16,5	800	1200	1800	28	487
TURBO-J150 BS	240	660	220	19,0	800	1200	1800	28	557
TURBO-J150 BP	240	660	220	19,0	800	1200	1800	28	557

AP



ELETTROPOMPE SOMMERSE PER POZZI DA 4" INTERAMENTE IN ACCIAIO INOX AISI 304
SUBMERSED ELECTRIC PUMPS, FOR 4 INCH WELLS FULLY IN STAINLESS STEEL AISI 304

PREVALENZA : 45 mt. ÷ 292 mt.
PORTATA : 2,4 m³/h ÷ 18 m³/h
POTENZA NOMINALE : 0,75 kW (1HP) ÷ 4 kW (5,5HP)

PUMP HEAD : 45,0 mt ÷ 292,0 mt
DELIVERY : 2,4 m³/h ÷ 18,0 m³/h
RATED HORSEPOWER : 0,75 kW (1,0HP) ÷ 4,0 kW (5,5HP)

APPLICAZIONI

- APPROVVIGIONAMENTO D'ACQUA.
- APPLICAZIONI CIVILI ED INDUSTRIALI.
- IMPIANTI ANTINCENDIO.
- IMPIANTI D'IRRIGAZIONE.

APPLICATIONS

- WATER SUPPLY.
- DOMESTIC AND INDUSTRIAL APPLICATIONS.
- FIRE FIGHTING.
- IRRIGATION.



ARVEN[®]
WATER PUMPS

CARATTERISTICHE DI COSTRUZIONE:

- MOTORE A BAGNO D'OLIO ATOSSICO E DIELETTRICO CONFORME ALLE NORME F.D.A. (FOOD AND DRUG ADMINISTRATOR)
- STATORE RIAVVOLGIBILE
- TENUTA MECCANICA CON PROTEZIONE ANTISABBIA
- IMMERSIONE MASSIMA POMPA: MT 150
- GRADO DI PROTEZIONE IP 68.
- CLASSE DI ISOLAMENTO: F
- TEMPERATURA MAX.LIQUIDO POMPATO: 35°C
- VERSIONI: Monofase: 220 - 277V/50Hz o 220 - 277V/60Hz
Trifase: 380 - 480V/50Hz o 380 - 480V/60Hz
- POTENZA MOTORE: Monofase: 0,75kW A 2,2 kW
Trifase: 0,75kW A 4 kW
- CAVO STANDARD: PIATTO 4X1,5mm
lunghezza: 1,5mt (0,75kw - 1,5kw); 2,5 (2,2 kw - 4 kw)
lunghezza 4X1,5mm : 1,5mt (0,75kw - 1,5kw); 2,5 (2,2 kw - 4 kw)
- Numero massimo di avviamenti per ora equamente distribuiti: 30

SPECIALI VOLTAGGI E FREQUENZE A RICHIESTA.

DESIGN ENGINEERING:

- OIL BATH MOTOR ATOSSIC AND DIELETTRIC CONSISTENT TO THE F.D.A. (FOOD AND DRUG ADMINISTRATOR NORMS)
- REWINDABLE STATOR
- MECHANICAL SEAL WITH PROTECTION AGAINST SAND
- PERMISSIBLE DRAUGHT OF WATER: 150 mt
- IP 68 PROTECTION CLASS
- CLASS "F" INSULATION
- MAX PUMP LIQUID TEMPERATURE: 35°
- VERSIONS: Single Phase: 220 - 277V/50Hz or 220 - 277V/60Hz
hree Phase: 380 - 480V/50Hz or 380 - 480V/60Hz
- MOTOR POWER: Single Phase: 0,75kW A 2,2 kW
Three Phase: 0,75kW A 4 kW
- STANDARD CABLE FEATURES: WIDE 4X1,5mm
length: 1,5mt (0,75kw - 1,5kw); 2,5 (2,2 kw - 4 kw)
4X1,5mm length: 1,5mt (0,75kw - 1,5kw); 2,5 (2,2 kw - 4 kw)
- Maximum numbers of starts for hour at regular intervals: 30

CUSTOMISED VOLTAGE AND FREQUENCY RATING AVAILABLE ON DEMAND

TABELLA MATERIALI / MATERIALS TABLE:

Pos.	Componente / Component	Materiale / Materials
A	Testata superiore piattello valvola sede valvola / Upper head, valve plate, valve seat	ACCIAIO INOX / (AISI 304 DIN 1.4301) / STAINLESS STEEL
B	Giranti / Impellers	ACCIAIO INOX / (AISI 304 DIN 1.4301) / STAINLESS STEEL
C	Albero (lato pompa) / Shaft (pump face)	ACCIAIO INOX / (AISI 420) / STAINLESS STEEL
F	Camicia esterna motore/ Outer shell	ACCIAIO INOX / (AISI 304 DIN 1.4301) / STAINLESS STEEL
G	Flangia di accoppiamento/ Connection flange	ACCIAIO INOX / (AISI 304 DIN 1.4301) / STAINLESS STEEL
M	Diffusori/ Diffusers	ACCIAIO INOX / (AISI 304 DIN 1.4301) / STAINLESS STEEL
L	Filtro/ Filters	ACCIAIO INOX / (AISI 304 DIN 1.4301) / STAINLESS STEEL

MODELLO type	DIMENSIONI ELETTROPOMPA Dimensions pump A=MM	PESO ELETTROPOMPA Weight pump Kg	HP	DIMENSIONI MOTORE Motor Dimensions B=MM	PESO MOTORE Weight Motor Kg
AP 10-18	532,00	4,9	1,0	423,00	9,9
AP 10-23	637,00	6,0	1,5	453,00	11,3
AP 10-28	742,00	6,8	2,0	493,00	13,1
AP 10-40	1029,00	9,8	3,0	543,00	15,4
AP 18-12	406,00	3,7	1,0	423,00	9,9
AP 18-18	532,00	4,9	1,5	453,00	11,3
AP 18-25	679,00	6,2	2,0	493,00	13,1
AP 18-33	847,00	7,8	3,0	543,00	15,4
AP 18-45	1134,00	10,5	5,0	513,00	14
AP 25-08	322,00	3,0	1,0	423,00	9,9
AP 25-12	406,00	3,6	1,5	453,00	11,3
AP 25-17	511,00	4,6	2,0	493,00	13,1
AP 25-21	595,00	5,5	3,0	543,00	15,4
AP 25-33	847,00	7,6	4,0	513,00	14
AP 25-44	1098,00	10,3	5,5	543,00	16,3
AP 40-12	701,00	7,8	3,0	543,00	15,4
AP 40-18	953,00	10,5	4,0	513,00	14
AP 40-25	1247,00	15,5	5,5	543,00	16,3
AP 70-07	636,00	6,6	3,0	543,00	15,4
AP 70-10	831,00	8,7	4,0	513,00	14
AP 70-13	1026,00	10,7	5,5	543,00	16,3

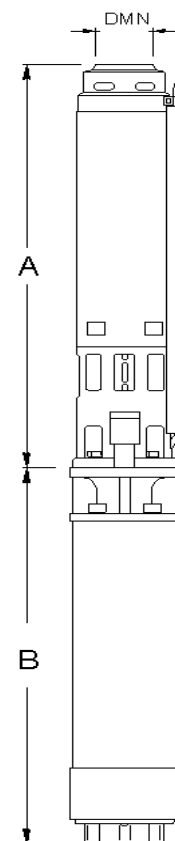

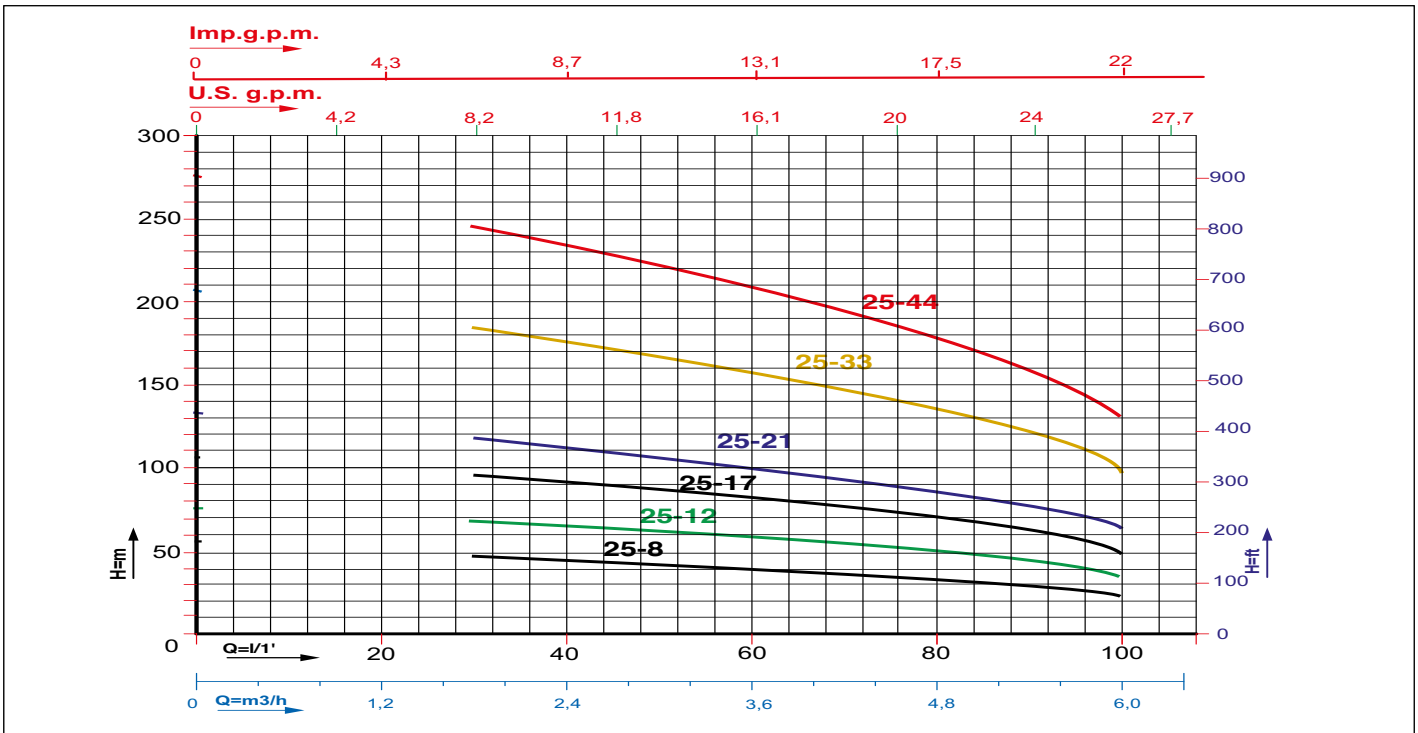
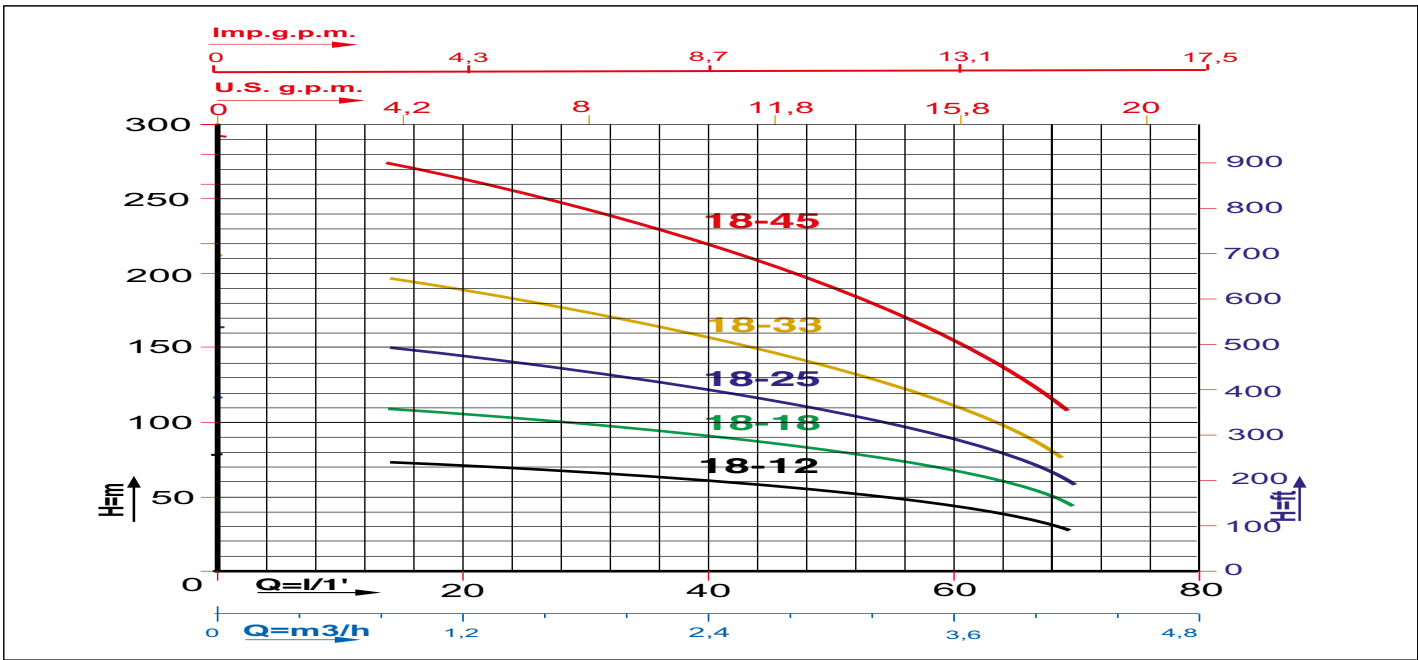
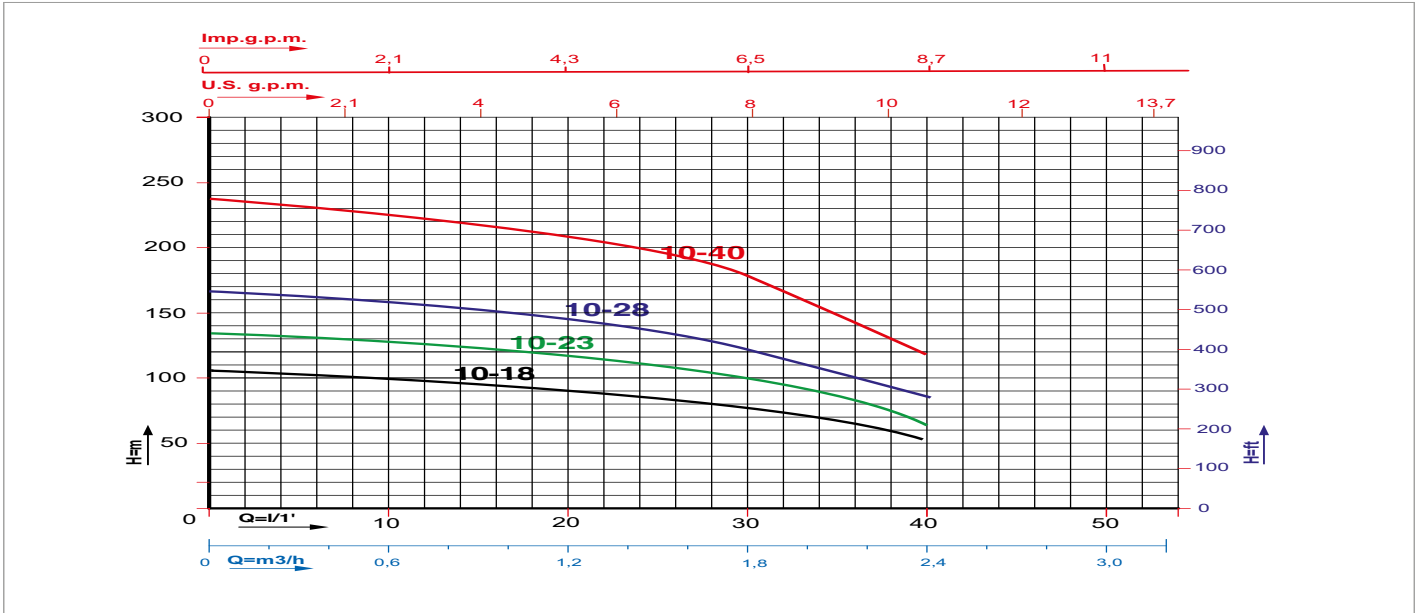

ST



ELETTROPOMPE SOMMERSE PER POZZI DA 4" SUBMERSED ELECTRIC PUMPS, FOR 4 INCH WELLS

PREVALENZA : 26 mt. ÷ 322 mt.
PORTATA : 1,5 m³/h ÷ 24 m³/h
POTENZA NOMINALE : 0,37 kW (0,5HP) ÷ 7,5 kW (10HP)

PUMP HEAD : 26,0 mt ÷ 322,0 mt
DELIVERY : 1,5 m³/h ÷ 24,0 m³/h
RATED HORSEPOWER : 0,37 kW (0,5HP) ÷ 7,5 kW (10,0HP)

APPLICAZIONI

- APPROVVIGIONAMENTO D'ACQUA.
- APPLICAZIONI CIVILI ED INDUSTRIALI.
- IMPIANTI ANTINCENDIO.
- IMPIANTI D'IRRIGAZIONE.

APPLICATIONS

- WATER SUPPLY.
- DOMESTIC AND INDUSTRIAL APPLICATIONS.
- FIRE FIGHTING.
- IRRIGATION.



ARVEN[®]
WATER PUMPS

CARATTERISTICHE DI COSTRUZIONE:

- MOTORE A BAGNO D'OLIO ATOSSICO E DIELETTRICO CONFORME ALLE NORME F.D.A. (FOOD AND DRUG ADMINISTRATOR)
- STATORE RIAVVOLGIBILE
- TENUTA MECCANICA CONPROTEZIONE ANTISABBIA
- IMMERSIONE MASSIMA POMPA: MT 150
- GRADO DI PROTEZIONE IP 68.
- CLASSE DI ISOLAMENTO: F
- TEMPERATURA MAX.LIQUIDO POMPATO: 35°C
- VERSIONI: Monofase: 220 - 277V/50Hz
Trifase: 380 - 480V/50Hz
- POTENZA MOTORE: Monofase: 0,75kW A 2,2 kW
Trifase: 0,75kW A 4 kW
- CAVO STANDARD: PIATTO 4X1,5mm lunghezza: 1,5mt (0,75kw - 1,5kw); 2,5 (2,2 kw - 5,5 kw),3mt (7,5kW)
- SPECIALI VOLTAGGI E FREQUENZE A RICHIESTA.

DESIGN ENGINEERING:

- OIL BATH MOTOR ATOSSIC AND DIELETTRIC CONSISTEN TO THE F.D.A. (FOOD AND DRUG AMMINISTRATOR NORMS)
- REWINDABLE STATOR
- MECHANICAL SEAL WITH PROTECTION AGAINST SAND
- PERMISSIBLE DRAUGHT OF WATER: 150 mt
- IP 68 PROTECTION CLASS
- CLASS "F" INSULATION
- MAX PUMP LIQUID TEMPERATURE: 35°
- VERSIONS: Single Phase: 220-277V/50Hz
Three Phase: 380-480V/50Hz
- MOTOR POWER: Single Phase: From 0,75kW To 2,2 kW
Three Phase: From 0,75 kW To 4 kW
- STANDARD CABL FEATURES:WIDE 4X1,5MM LENGHT; 1,5mt (o.75kW-1,5kW); 2,5 (2,2 kW-5,5kW), 3mt (7,5 kW)
- CUSTOMISED VOLTAGE AND FREQUENCY RATING AVAILABLE ON DEMAND.

TABELLA MATERIALI / MATERIALS TABLE:

Pos.	Componente / Component	Materiale / Materials
A	Testata superiore piattello o valvola/ Upper head, valve plate	ACCIAIO INOX (AISI 304 DIN 1.4301) / STAINLESS STEEL
B	Girante / Impeller	TECNOPOLIMERO / TECNOPOLYMER
C	Albero (lato pompa) / Shaft (pump face)	ACCIAIO INOX / (AISI 420) / STAINLESS STEEL
F	Camicia esterna motore / Outer shell	ACCIAIO INOX (AISI 304 DIN 1.4301) / STAINLESS STEEL
G	Flangia di accoppiamento/ Connection flange	OTTONE / BRASS
M	Diffusori / Diffusers	TECNOPOLIMERO / TECNOPOLYMER
L	Filtro / Filters	ACCIAIO INOX (AISI 304 DIN 1.4301) / STAINLESS STEEL

MODELLO TYPE	DIMENSIONI ELETTROPOMPA Dimension pump A=MM	PESO ELETTROPOMPA Weight pump Kg	HP	DIMENSIONI MOTORE Motor Dimensions B=MM	PESO MOTORE Weight Motor Kg
ST 05-10	324,00	3,3	0,50	373,00	7,70
ST 05-13	377,00	3,7	0,50	373,00	7,70
ST 05-19	481,00	4,7	0,75	393,00	8,60
ST 05-26	642,00	5,8	1,00	423,00	9,60
ST 10-07	271,00	2,8	0,50	373,00	7,70
ST 10-10	324,00	3,3	0,75	393,00	8,60
ST 10-14	394,00	3,9	1,00	423,00	9,90
ST 10-20	499,00	4,9	1,50	453,00	11,3

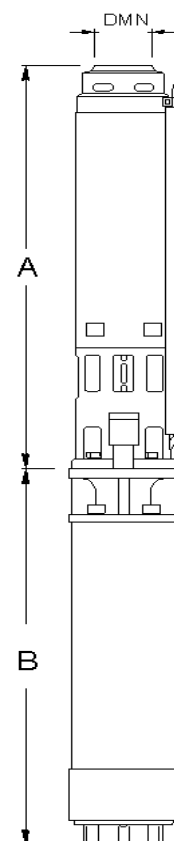

MODELLO type	DIMENSIONI ELETTROPOMPA Dimensionspumpm A=MM	PESO ELETTROPOMPA Weight pumpm Kg	HP	DIMENSIONI MOTORE Motor Dimensions B=MM	PESO MOTORE Weight Motor Kg
ST 13-05	236,00	2,5	0,50	373,00	7,70
ST 13-08	289,00	2,9	0,75	393,00	8,60
ST 13-11	342,00	3,4	1,00	423,00	9,90
ST 13-16	430,00	4,2	1,50	453,00	11,3
ST 13-21	519,00	5,0	2,00	493,00	13,1
ST 13-32	749,00	7,1	3,00	543,00	15,4
ST 18-05	257,00	2,7	0,50	373,00	7,70
ST 18-07	301,00	3,0	0,75	393,00	8,60
ST 18-09	344,00	3,3	1,00	423,00	9,90
ST 18-14	452,00	4,1	1,50	453,00	11,3
ST 18-18	538,00	4,7	2,00	493,00	13,1
ST 18-27	767,00	6,2	3,00	513,00	14,0
ST 18-35	934,00	7,9	4,00	543,00	15,4
ST 18-48	1250,00	9,9	5,50	543,00	16,3
ST 25-08	345,00	3,3	1,00	423,00	9,90
ST 25-12	433,00	4,1	1,50	453,00	11,3
ST 25-16	542,00	5,0	2,00	493,00	13,1
ST 25-24	777,00	6,6	3,00	513,00	14,0
ST 25-32	965,00	8,7	4,00	543,00	15,4
ST 25-40	1160,00	10,4	5,50	543,00	16,3
ST 25-44	1296,00	11,2	5,50	543,00	16,3
ST 35-07	390,00	3,7	1,00	423,00	9,90
ST 35-10	483,00	4,6	1,50	453,00	11,3
ST 35-14	607,00	5,7	2,00	493,00	13,1
ST 35-20	831,00	7,5	3,00	513,00	14,0
ST 35-27	1048,00	9,6	4,00	543,00	15,4
ST 35-34	1257,00	11,6	5,50	543,00	16,3
ST 35-36	1318,00	12,2	5,50	543,00	16,3
ST 35-49	1802,00	15,9	7,50	623,00	20,0
ST 40-04	294,00	2,8	1,00	423,00	9,90
ST 40-06	356,00	3,4	1,50	453,00	11,3
ST 40-08	418,00	4,0	2,20	493,00	13,1
ST 40-13	573,00	5,5	3,00	513,00	14,0
ST 40-17	697,00	6,6	4,00	543,00	15,4
ST 40-23	921,00	8,4	5,50	543,00	16,3
ST 40-32	1238,00	11,0	7,50	623,00	20,0
ST 80-08	676,00	6,3	3,00	513,00	14,0
ST 80-11	880,00	8,1	4,00	543,00	15,4
ST 80-15	1149,00	10,5	5,50	543,00	16,3
ST 80-20	1489,00	13,5	7,50	623,00	25,5
ST 80-26	1810,00	17,5	10,00	703,00	25,5

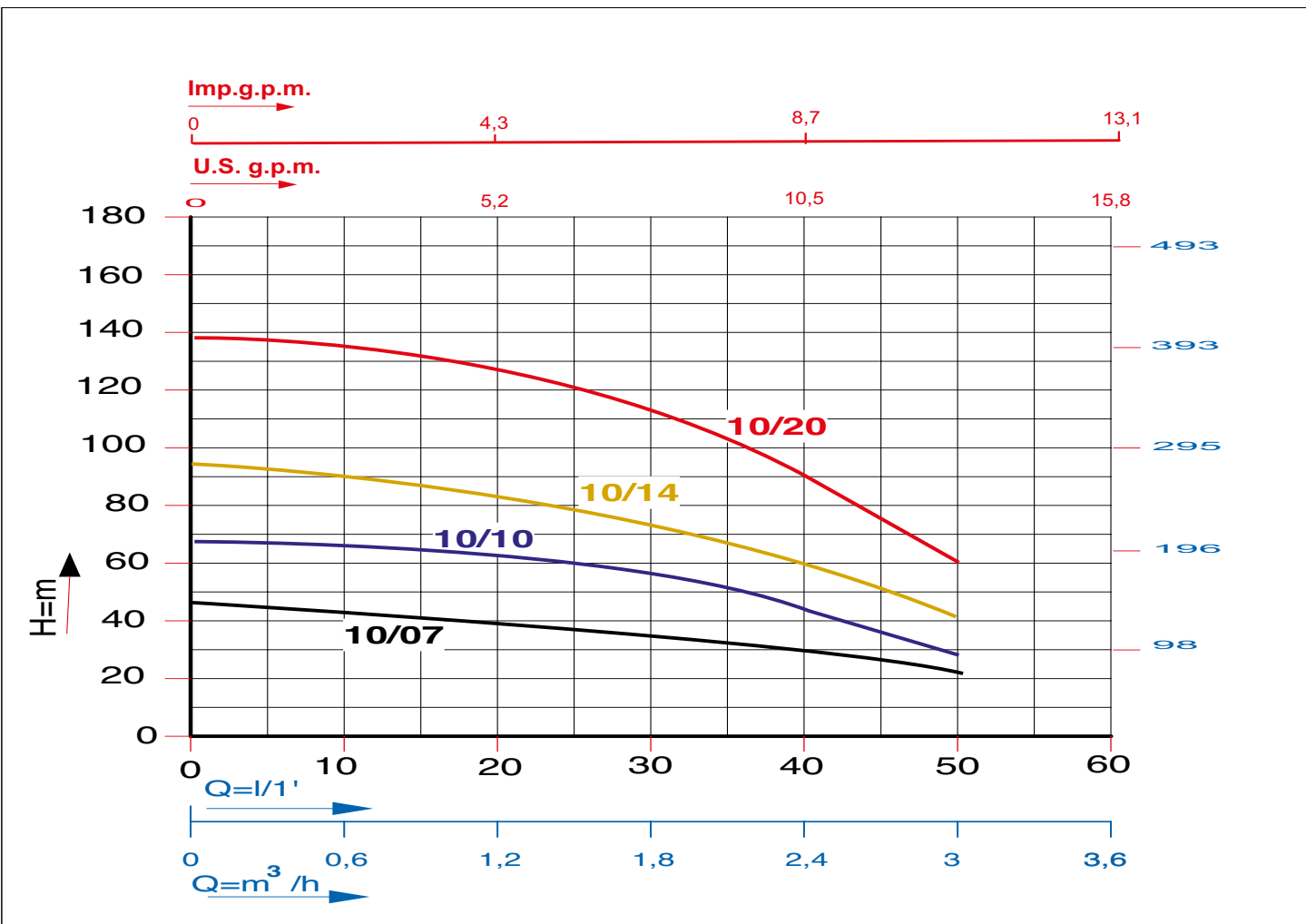
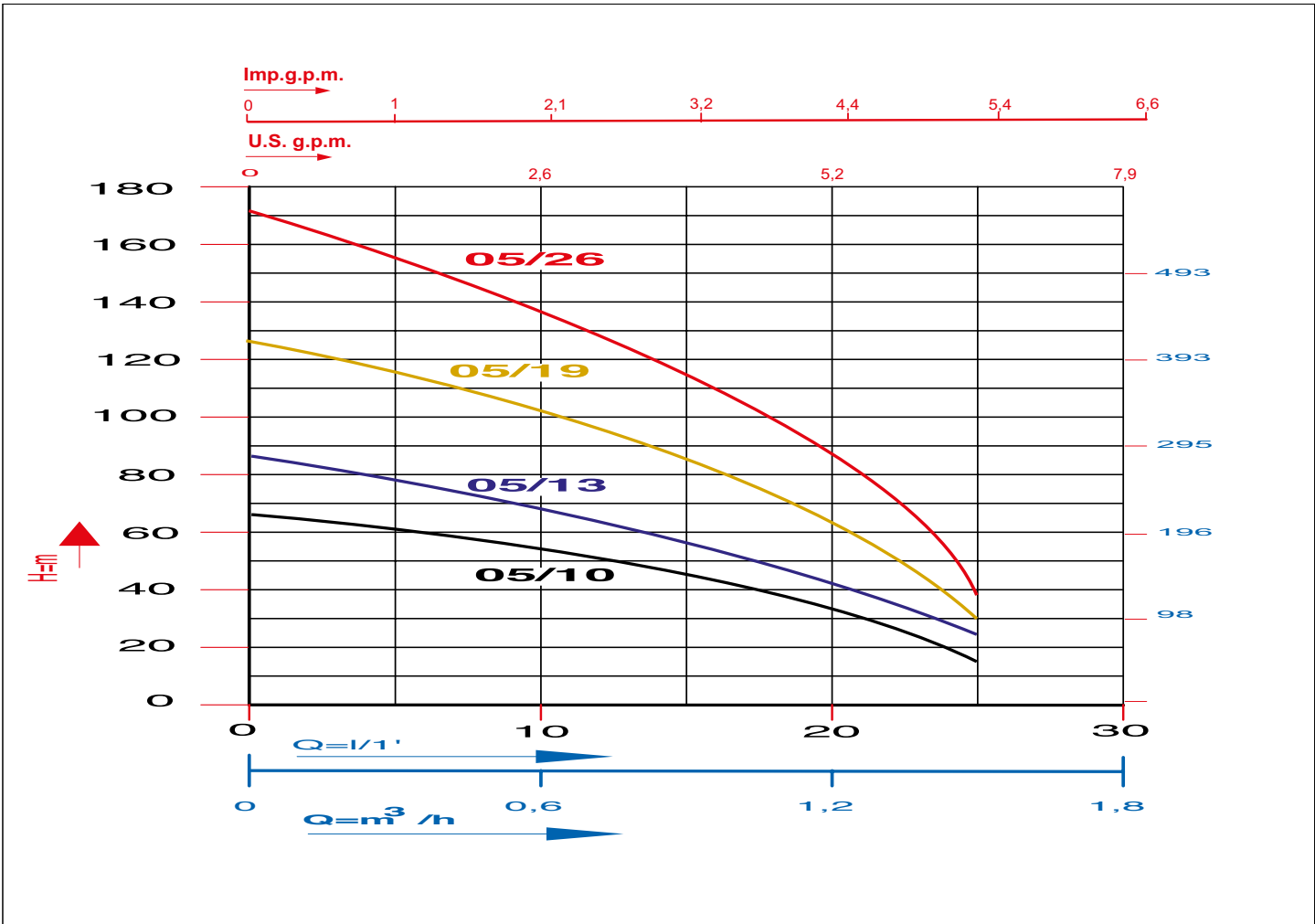

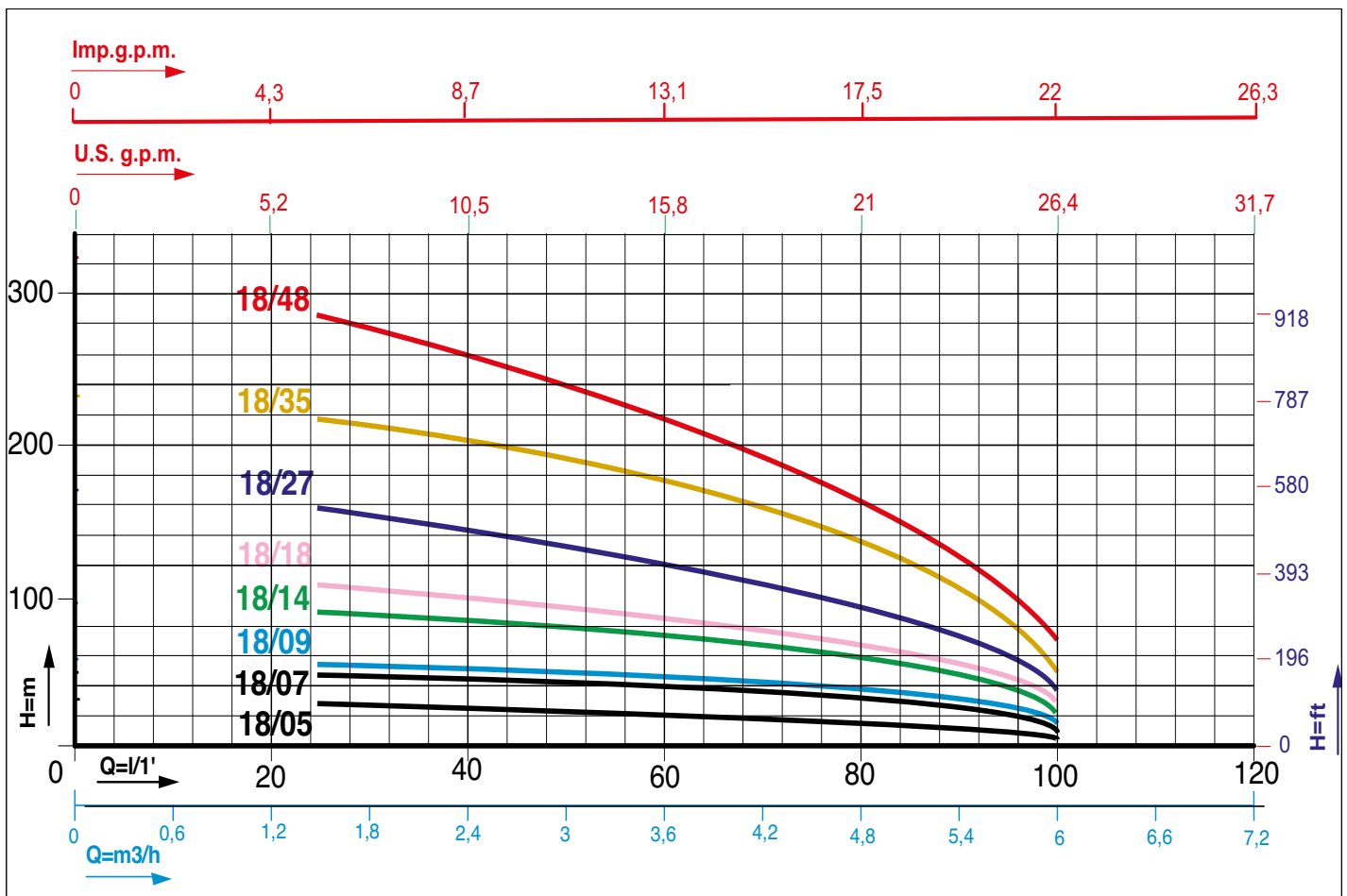
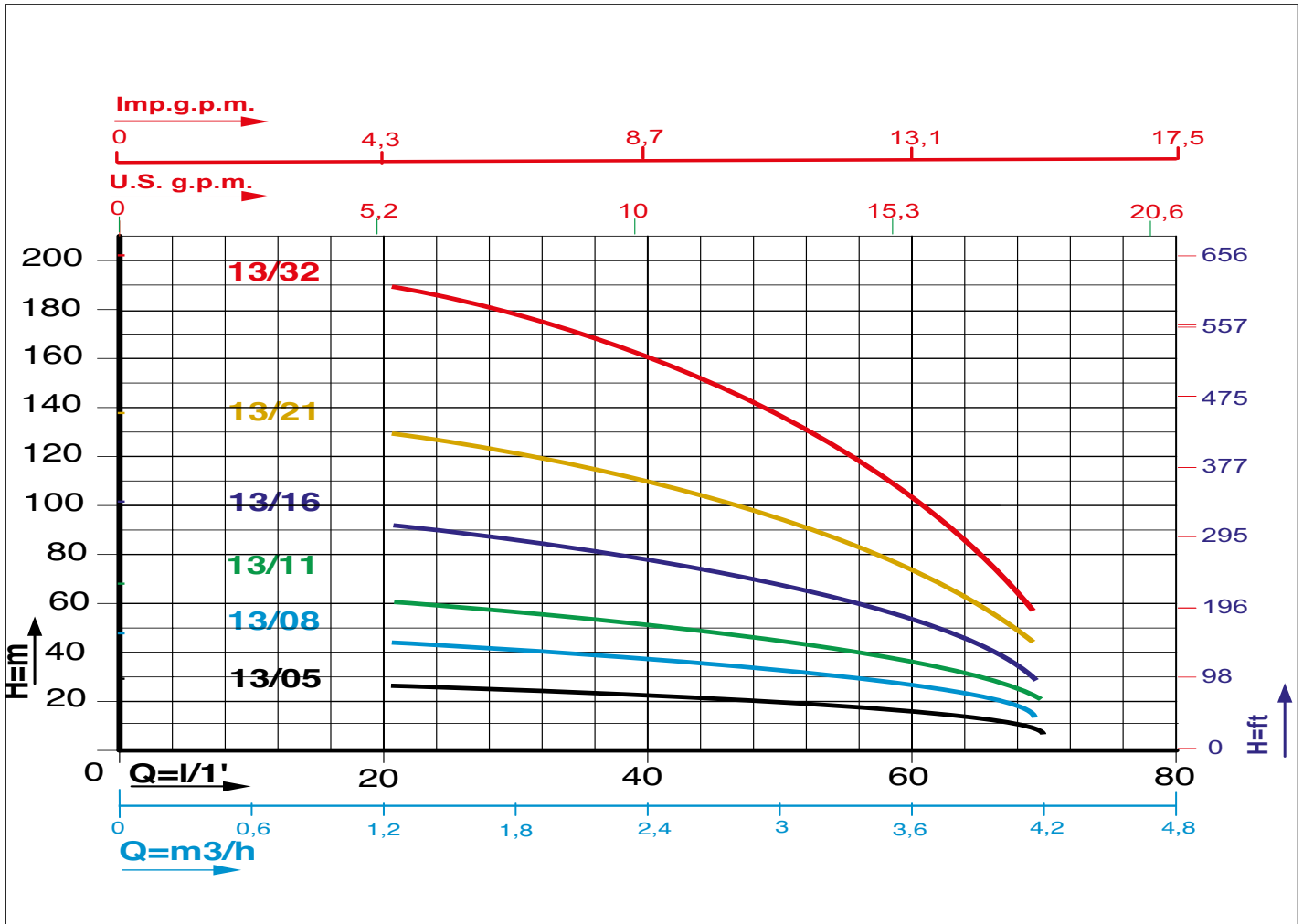

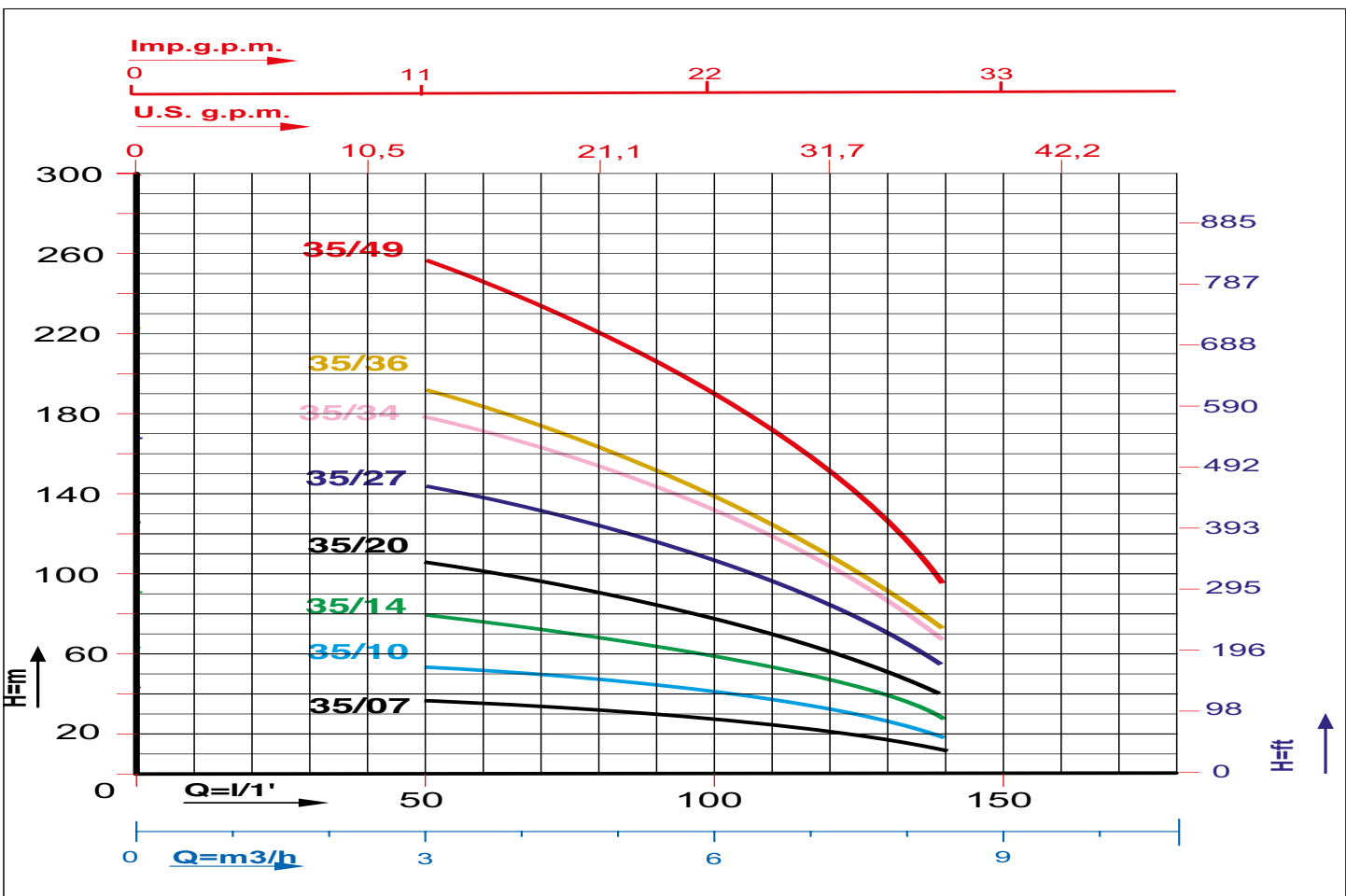
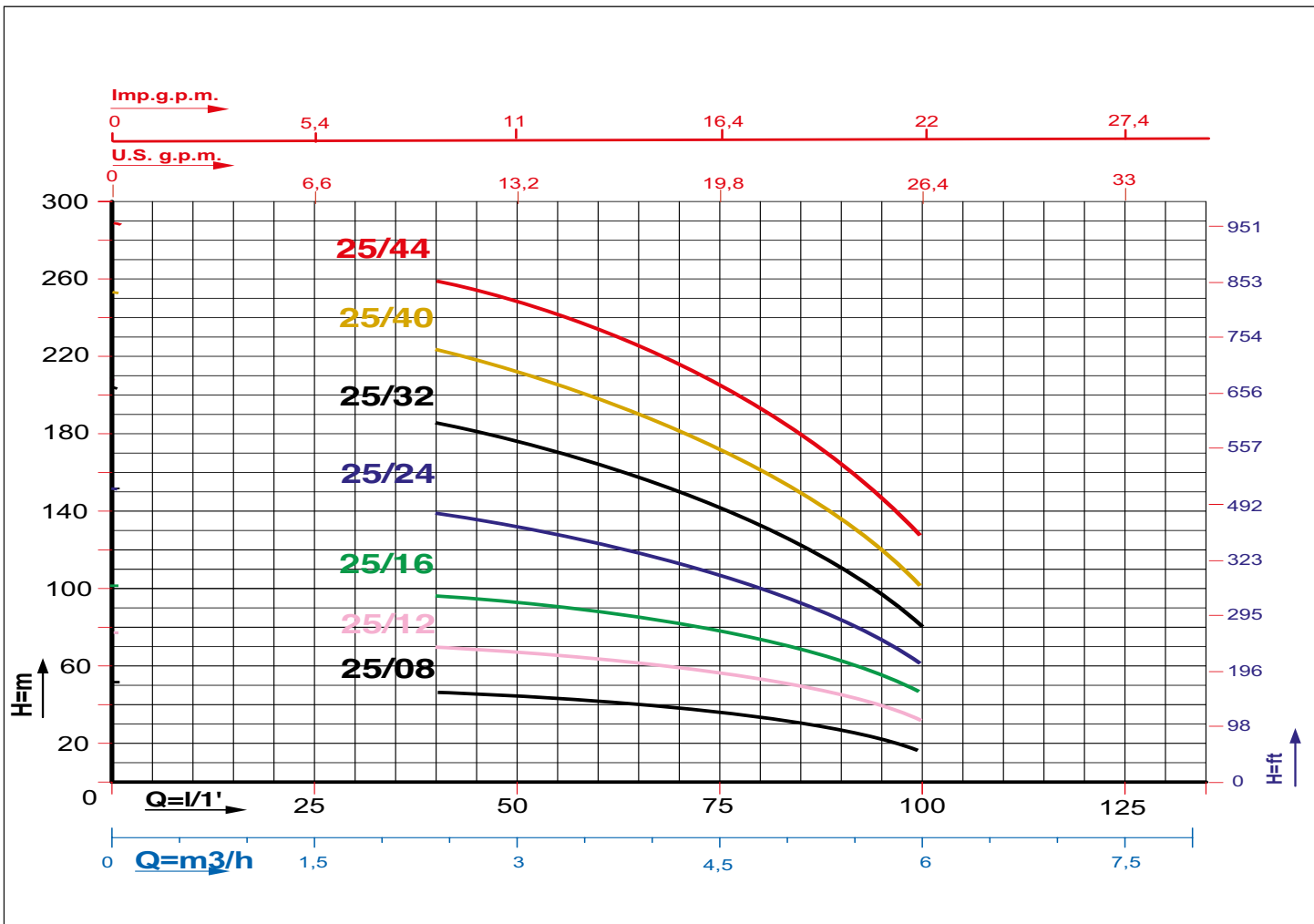

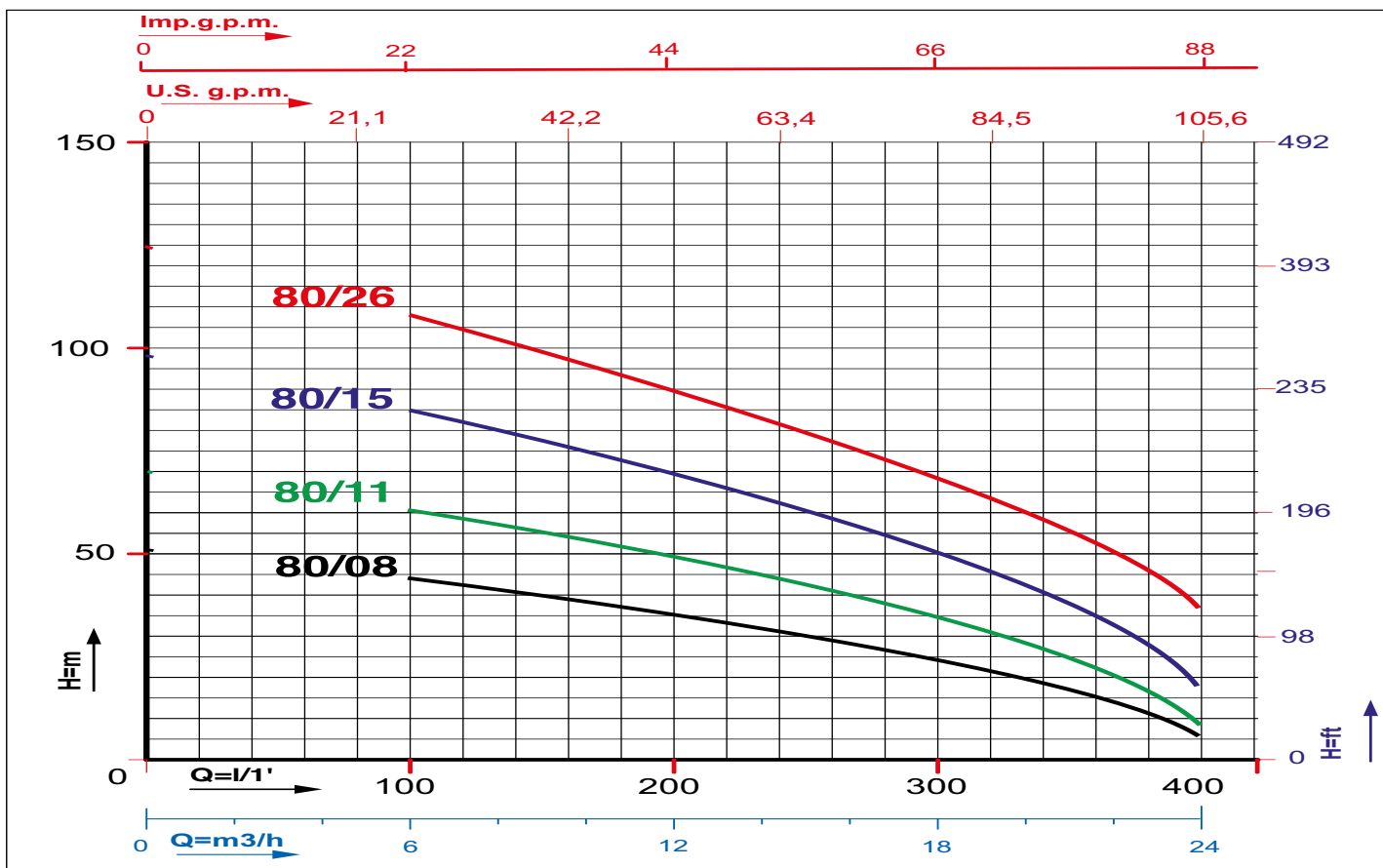
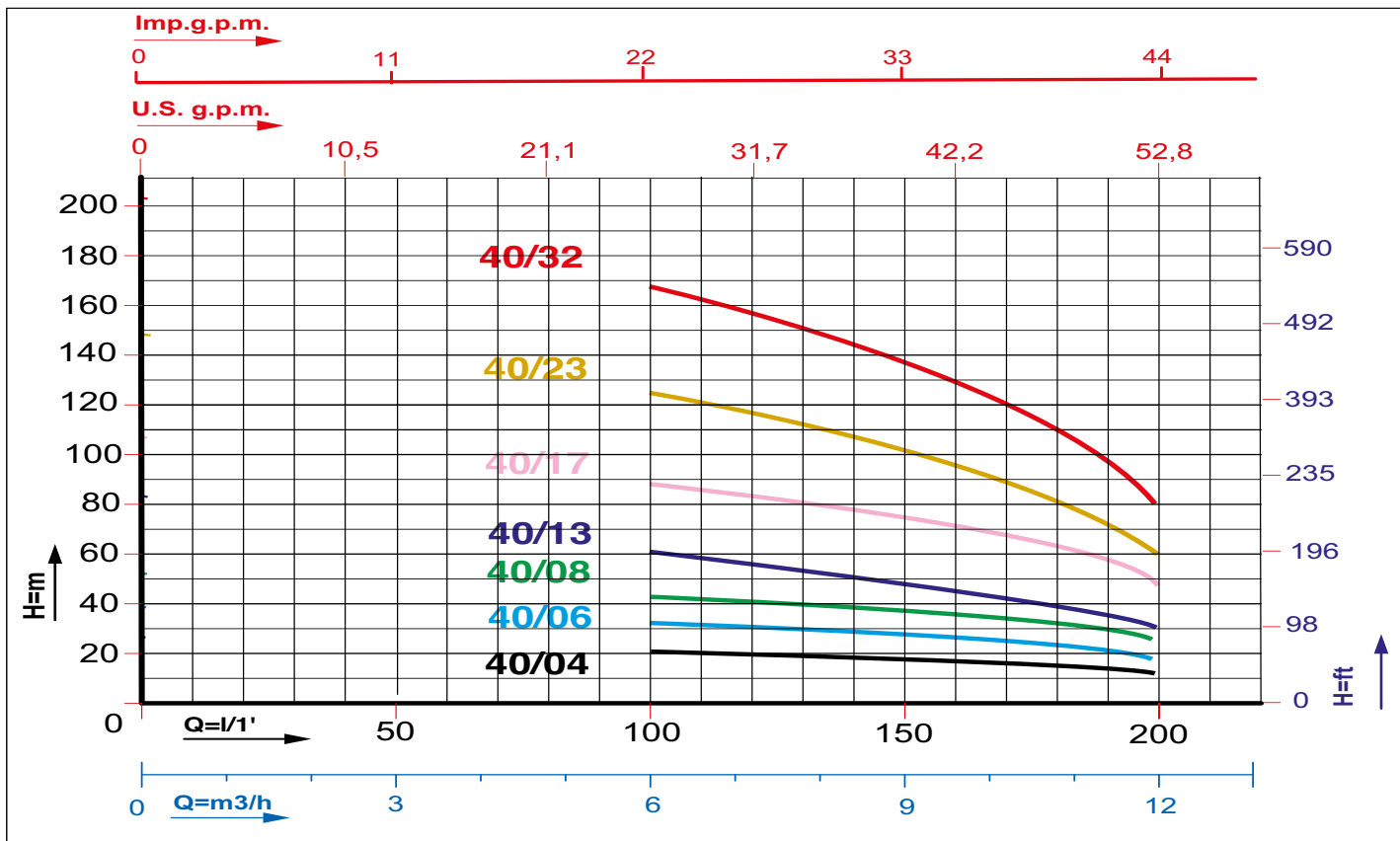

Caratteristiche di funzionamento a 2800 rpm 50Hz e 3450 rpm 60Hz - Performances at 2800 rpm 50 Hz and 3450 rpm 60 Hz
 Le prestazioni valgono per liquidi con densità $\rho = 1,0 \text{ kg/dm}^3$ ed una viscosità $\nu = 1 \text{ mm}^2/\text{s}$ / The performance data holds true for liquids with a $\rho = 1,0 \text{ kg/dm}^3$ density and a $\nu = 1 \text{ mm}^2/\text{s}$ viscosity.

OP

MOTORE ELETTRICO SOMMERSO 4" SUBMERSIBLE MOTOR 4"



- OP - B:** Flangia di accoppiamento a norme NEMA4" in Ottone stampato.
- OP - C:** Flangia di accoppiamento a norme NEMA4" in Ghisa trattata anticorrosione.
- OP - S:** Flangia di accoppiamento a norme NEMA4" in AISI 316.

Camicia esterna in AISI 304 - AISI 316.
 Gruppo prigioniero, rondelle e dadi per accoppiamento pompa in AISI 304-AISI 316.
 Terminale albero motore in Duplex®.
 Potenza: monofase 0,37 kW - 3,7 kW.
 trifase 0,37 kW - 7,5 kW .
 Tensioni: monofase 230V ± 10% 50Hz o 60Hz.
 trifase 230V o 400V ± 10% 50Hz o 60Hz.
 Carico assiale: 2500N - 4500N.
 Protezione IP 68, Classe di isolamento F.
 Cavo piatto 4x1,5mm² dimensioni 15,5x5,5mm.
 Lunghezza: 1,5mt (0,37 kW - 1,5 kW)
 2,5mt (2,2 kW - 5,5 kW)
 3,0mt (7,5 kW)

LIMITI D'IMPIEGO

Numero massimo di avviamenti per ora: 30.
 Temperatura ambiente max. 35°C, acqua pH 6,5 - 8,0.
 Velocità min. di raffreddamento 8cm/sec.
 Profondità massima di immersione 350mt.
 Montaggio: verticale/orizzontale

- OP - B:** Pressed Brass coupling flange 4" according NEMA rules.
- OP - C:** Cast Iron with anti-corrosive treatment coupling flange 4" according NEMA rules.
- OP - S:** Coupling flange 4" according NEMA rules of SS AISI316.

Outer shell of SS AISI 304 - AISI 316.
 Stud-bolt, washers and nuts for pump coupling of SS AISI 304 - AISI 316.
 Shaft extension of SS Duplex®.
 Power: single-phase 0,37 kW - 3,7 kW.
 three-phase 0,37 kW - 7,5 kW.
 Voltage: single-phase 230V ± 10% 50Hz or 60Hz.
 three-phase 230V or 400V ± 10% 50Hz or 60Hz.
 Axial load: 2500 N - 4500 N.
 Protection IP 68, Insulation class F
 Flat cable 4x1,5mm² dimensions 15,5x5,5mm.
 Length: 1,5mt (0,37 kW - 1,5 kW)
 2,5mt (2,2 kW - 5,5 kW)
 3,0mt (7,5 kW).

LIMITS OF USE

Max. starting operations per hour: 30.
 Max. ambient temperature 35°C, water pH 6,5 - 8,0.
 Min. cooling speed: 8 cm/sec.
 Max. depth of immersion: 350 mt.
 Vertical or horizontal installation.

SERIE	Pn		V	c 450V µF	RPM	cos	n %	In A	S.F.	N	H	m
	kW	Hp									mm	kg
OPM 0500	0,37	0,50	230	20	2840	0,93	58	3,1	1,0	2500	373	7,7
OPM 0750	0,55	0,75	230	25	2820	0,97	64	5,0	1,0	2500	393	8,6
OPM 1000	0,75	1,00	230	36	2840	0,95	69	6,2	1,0	2500	423	9,9
OPM 1500	1,10	1,50	230	40	2830	0,94	71	8,5	1,0	2500	453	11,3
OPM 2000	1,50	2,00	230	50	2840	0,94	73	10,8	1,0	2500	493	13,1
OPM 3000	2,20	3,00	230	80	2840	0,97	74	15,5	1,0	2500	543	15,4
OPM 5000	3,70	5,00	230	125	2840	0,99	74	22,4	1,0	4500	823	27,5

SERIE	Pn		V	RPM	cos	n %	In A	S.F.	N	H	m
	kW	Hp								mm	kg
OPT 0500	0,37	0,50	400	2810	0,78	64	1,2	1,0	2500	373	7,2
OPT 0750	0,55	0,75	400	2810	0,78	67	1,6	1,0	2500	373	7,8
OPT 1000	0,75	1,00	400	2820	0,78	69	2,2	1,0	2500	393	8,8
OPT 1500	1,10	1,50	400	2820	0,78	74	3,0	1,0	2500	423	10,1
OPT 2000	1,50	2,00	400	2820	0,76	76	4,2	1,0	2500	453	11,4
OPT 3000	2,20	3,00	400	2820	0,79	77	6,2	1,0	2500	493	13,2
OPT 4000	3,00	4,00	400	2840	0,85	79	7,1	1,0	2500	513	14,0
OPT 5500	4,00	5,50	400	2840	0,84	80	9,4	1,0	2500	543	16,3
OPT 7500	5,50	7,50	400	2840	0,81	80	13,3	1,0	2500	623	19,6
OPT 1000	7,50	10,00	400	2810	0,76	80	18,0	1,0	4500	853	28,5

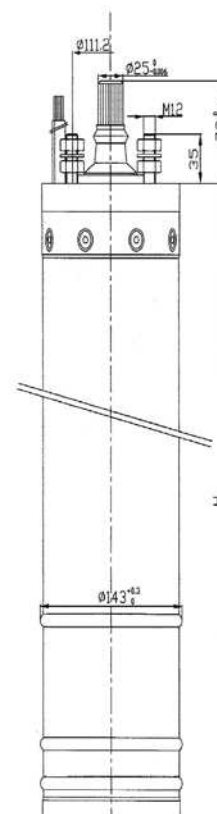

Modifiche tecniche senza obbligo di preavviso - Technical modifications without prior notice

Legenda: PN=potenza nominale/rated power, C=condensatore/capacitor, COS =fattore potenza/power facto

IN=corrente nominale/rated current, N=carico assiale/axial load



NCC 24

ELETTROPOMPE A 24 VOLT 24 VOLT ELECTROPUMPS



APPLICAZIONI

- PER PISCINE
- SVUOTAMENTO NATANTI

APPLICATIONS

- FOR SWIMMING POOL
- FOR EMPTYING BOAT

CARATTERISTICHE COSTRUTTIVE

Corpo pompa: PP30V
Classe di isolamento: F
Classe di protezione: IP 68
Girante: NORYL

MAIN FACTURES

Pump body: PP30V
Insulation class: F
Protection class: IP68
Impeller: NORYL

DRENAGGIO / DRAINAGE

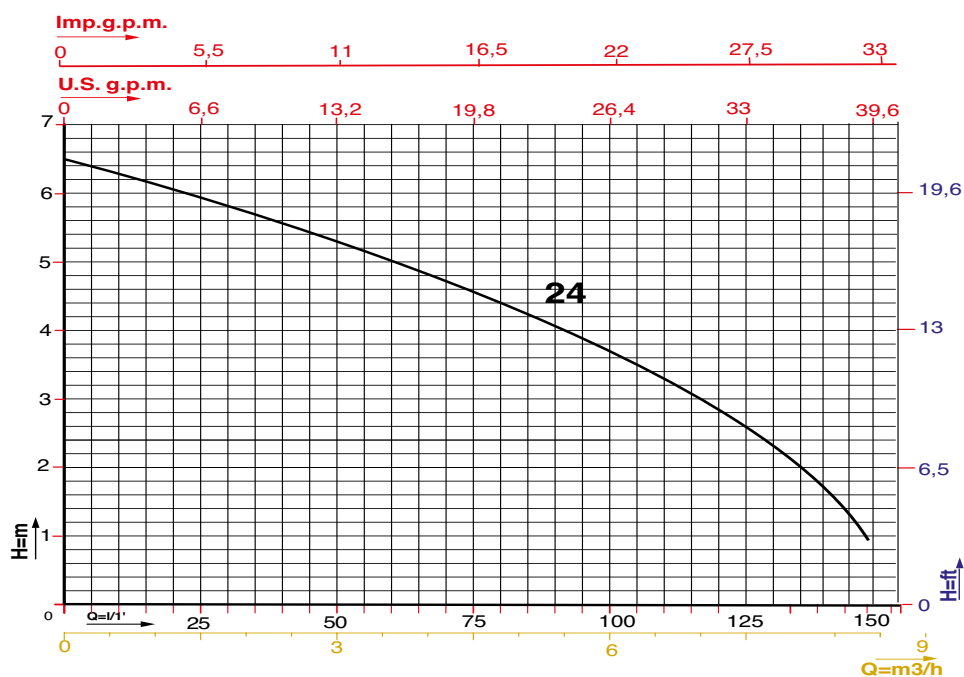

TYPE	HP (P2)	kW (P1)	VOLT	AMP
NCC 24	0,37	0,3	24V - DC	13

Q l/min	0	20	50	100	150
Q m3/h	0	1,2	3	6	9
H/m	6,5	5,8	4,9	3,0	0,9

TYPE	L	N	M	KG	Q: F
NCC 24	220	370	170	5,2	

NCC 24 T

ELETTROPOMPE A 24 VOLT 24 VOLT ELECTROPUMPS



APPLICAZIONI

- PER PISCINE
- SVUOTAMENTO NATANTI

APPLICATIONS

- FOR SWIMMING POOL
- FOR EMPTYING BOAT

CARATTERISTICHE COSTRUTTIVE

Corpo pompa: PP30V
Classe di isolamento: F
Classe di protezione: IP 68
Girante: NORYL

MAIN FACTURES

Pump body: PP30V
Insulation class: F
Protection class: IP68
Impeller: NORYL

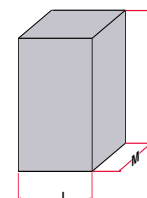
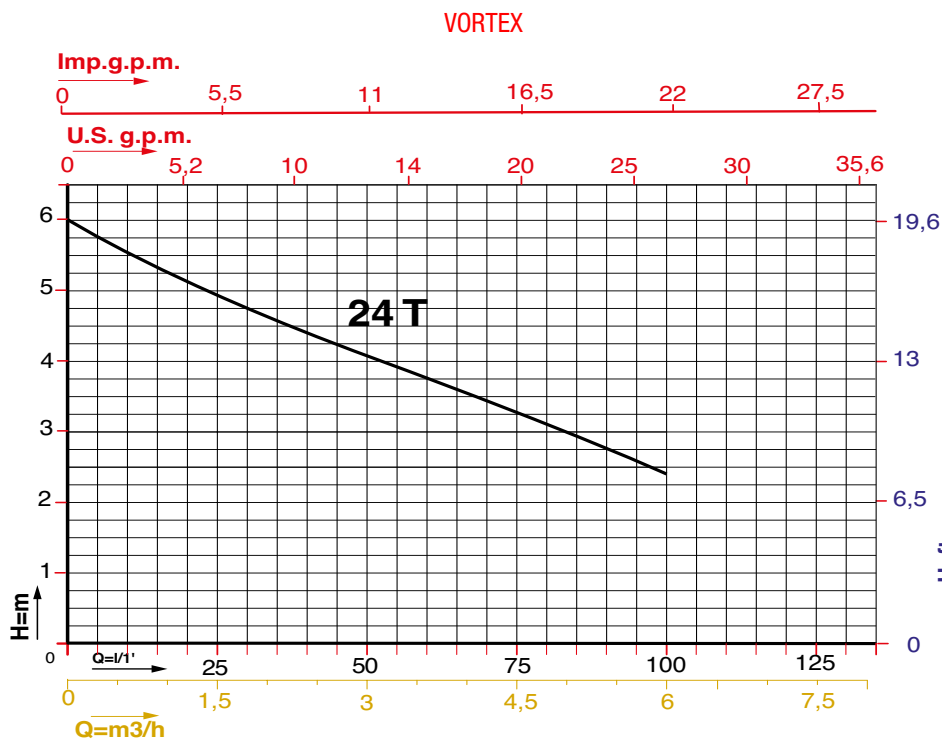

TYPE	HP (P2)	kW (P1)	VOLT	AMP
NCC 24 T	0,48	0,38	24V - DC	17

Q l/min	0	20	50	100	150
Q m ³ /h	0	1,2	3	6	9
H/m	6,0	5,0	4,2	2,5	---

TYPE	L	N	M	KG	Q.TY EU/ PALLE
NCC 24 T	220	370	170	6,7	100

SPA

ELETTROPOMPE SOMMERGIBILI IN PLASTICA DRENAGGIO PER ACQUE CHIARE PLASTIC SUBMERSIBLE PUMPS FOR WHITE WATER DRAINAGE



APPLICAZIONI

- SVUOTAMENTO DA ACQUE PIOVANE D'INFILTRAZIONE, DI POZZETTI O VASCHE DI RACCOLTA
- PRELIEVO DA VASCHE DI RACCOLTA DI ACQUE PIOVANE PER PICCOLE IRRIGAZIONI A SCORRIMENTO DI ORTI E GIARDINI.
- TRAVASO DI ACQUA CHIARA DA SERBATOI E VASCHE

APPLICATIONS

- RAIN, SEEPAGE, SUMP PIT AND CATCH TANK WATER PUMP OUT
- GARDEN AND VEGETABLE GARDEN MINI FLOOD IRRIGATION SYSTEM RAIN WATER CATCH TANK PUMP DOWN
- WHITE WATER PUMP OVER FROM RESERVOIRS AND VATS

DRENAGGIO / DRAINAGE

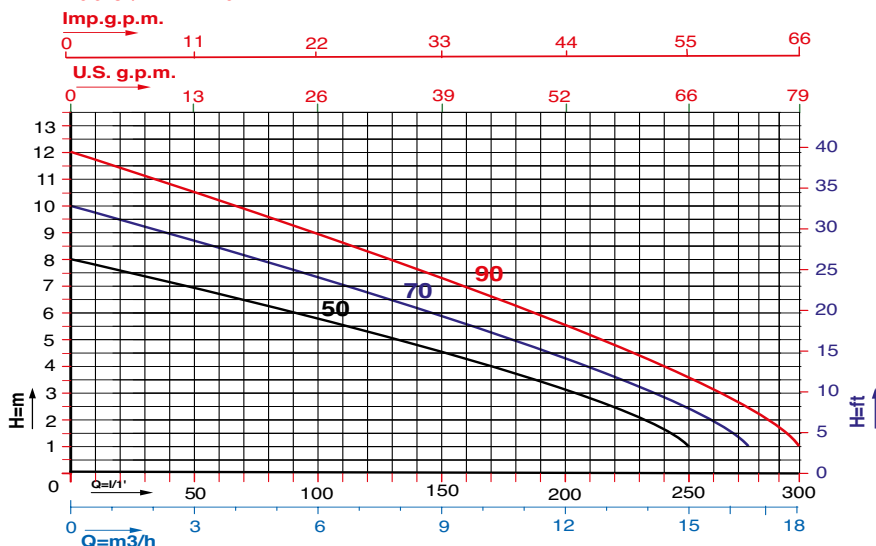

CARATTERISTICHE COSTRUTTIVE:

Corpo pompa: PP30FV
 Motore: Raffreddato ad acqua/cassa lega G-Al Si 9
 Albero motore: Acciaio inox AISI F - Terminale in ceramica (SPA 700) con camera d'olio
 Classe isolamento: F
 Classe protezione: IP 68
 Tenuta: Paraoli ad alta resistenza
 Utilizzo: Intermittente (SPA 300-SPA 500)

MAIN FEATURES:

Pump body: PP30FV
Motor: Water cooled/casing made of G-Al Si 9 alloy
Motor shaft: Stainless steel AISI 430 F - Ceramic shaft terminal (SPA 700) with oil chamber
Insulation class: F
Protection class: IP 68
Seal: High resistant lip seals
Duty: Intermittant (SPA 300-SPA 500)

DIMENSIONI/Dimensions

TYPE	DNA	DNM	a	b	c	d	e	f
SPA 50	-	M 1"1/4	400	152	132	50	285	395
SPA 70	-	F 1"1/4	400	152	132	70	311	440
SPA 90	-	F 1"1/4	400	152	130	70	311	440

DATI ELETTRICI / ELECTRICAL DATA

TYPE	HP (P2)	kW (P2)	kW (P1)	230V 50Hz ~1	µF	r.p.m.	Temp Max
SPA 50	0,60	0,45	0,57	2,55	8	2800	35°C
SPA 70	0,80	0,60	0,76	3,45	12	2800	35°C
SPA 90	0,95	0,70	0,96	4,20	16	2800	35°C

IMBALLO/Packaging

L	N	M	Kg	Q.ty euro pallett
220	370	170	5,2	100
220	370	170	6.7	100
220	370	170		

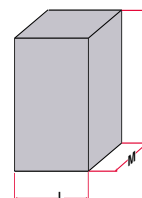

SPM

ELETTROPOMPE SOMMERGIBILI IN PLASTICA (VORTEX) PLASTIC SUBMERSIBLE PUMPS



APPLICAZIONI

- SVUOTAMENTO DA ACQUE PIOVANE D'INFILTRAZIONE, DI POZZETTI O VASCHE DI RACCOLTA
- PRELIEVO DA VASCHE DI RACCOLTA DI ACQUE PIOVANE PER PICCOLE IRRIGAZIONI A SCORRIMENTO DI ORTI E GIARDINI.
- TRAVASO DI ACQUA CHIARA DA SERBATOI E VASCHE

VORTEX

- PASSAGGIO SOLIDI FINO A 30 MM

APPLICATIONS

- RAIN, SEEPAGE, SUMP PIT AND CATCH TANK WATER PUMP OUT
- GARDEN AND VEGETABLE GARDEN MINI FLOOD IRRIGATION SYSTEM RAIN WATER CATCH TANK PUMP DOWN
- WHITE WATER PUMP OVER FROM RESERVOIRS AND VATS

VORTEX

- SOLID MATTER BYPASS UP TO 30 MM

VORTEX

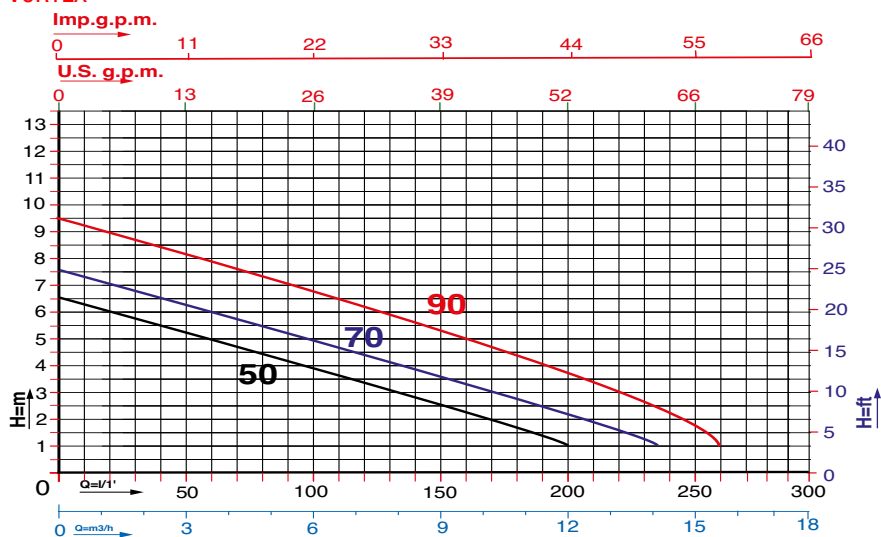

CARATTERISTICHE COSTRUTTIVE:

Corpo pompa: PP30FV
 Motore: Raffreddato ad acqua/cassa lega G-Al Si 9
 Albero motore: Acciaio inox AISI F - Terminale in ceramica (SPA 700) con camera d'olio
 Classe isolamento: F
 Classe protezione: IP 68
 Tenuta: Paraoli ad alta resistenza
 Utilizzo: Intermittente (SPM 500)

MAIN FEATURES:

Pump body: PP30FV
Motor: Water cooled/casing made of G-Al Si 9 alloy
Motor shaft: Stainless steel AISI 430 F - Ceramic shaft terminal (SPA 700) with oil chamber
Insulation class: F
Protection class: IP 68
Seal: High resistant lip seals
Duty: Intermittant (SPM 500)

DIMENSIONI/Dimensions								
TYPE	DNA	DNM	a	b	c	d	e	f
SPM 50	Ø30	M 1"1/4	400	152	130	60	295	380
SPM 70	Ø30	F 1"1/4	400	152	130	120	347	440
SPM 90	Ø30	F 1"1/4	400	152	130	120	347	440

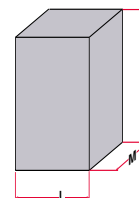

DATI ELETTRICI / ELECTRICAL DATA								IMBALLO/Packaging				
TYPE	HP (P2)	kW (P2)	kW (P1)	230V 50Hz ~1	µF	r.p.m.	Temp Max	L	N	M	Kg	Q.ty euro pallett
SPM 50	0,60	0,45	0,52	2,4	8	2800	35°C	220	370	170	5,2	100
SPM 70	0,80	0,60	0,68	3,10	12	2800	35°C	220	370	170	6,6	100
SPM 90	0,95	0,70	0,83	3,65	16	2800	35°C	220	370	170	7,7	100

MAXIMA

ELETTROPOMPE SOMMERSIBILI IN PLASTICA DRENAGGIO PER ACQUE SPORCHE (VORTEX) PLASTIC SUBMERSIBLE PUMPS FOR FOUL WASTE WATER DRAINAGE (VORTEX)



APPLICAZIONI

- SVUOTAMENTO DA ACQUE PIOVANE D'INFILTRAZIONE, DI POZZETTI O VASCHE DI RACCOLTA
- PRELIEVO DA VASCHE DI RACCOLTA DI ACQUE PIOVANE PER PICCOLE IRRIGAZIONI A SCORRIENTO DI ORTI E GIARDINI.
- TRAVASO DI ACQUA CHIARA DA SERBATOI E VASCHE

APPLICATIONS

- RAIN, SEEPAGE, SUMP PIT AND CATCH TANK WATER PUMP OUT
- GARDEN AND VEGETABLE GARDEN MINI FLOOD IRRIGATION SYSTEM RAIN WATER CATCH TANK PUMP DOWN
- WHITE WATER PUMP OVER FROM RESERVOIRS AND VATS

VORTEX

- PASSAGGIO SOLIDI FINO A 30 MM (VXP400)
- PASSAGGIO SOLIDI FINO A 35 MM (VXP550)

VORTEX

- SOLID MATTER BYPASS UP TO 30 MM (VXP 400)
- SOLID MATTER BYPASS UP TO 35 MM (VXP 550)

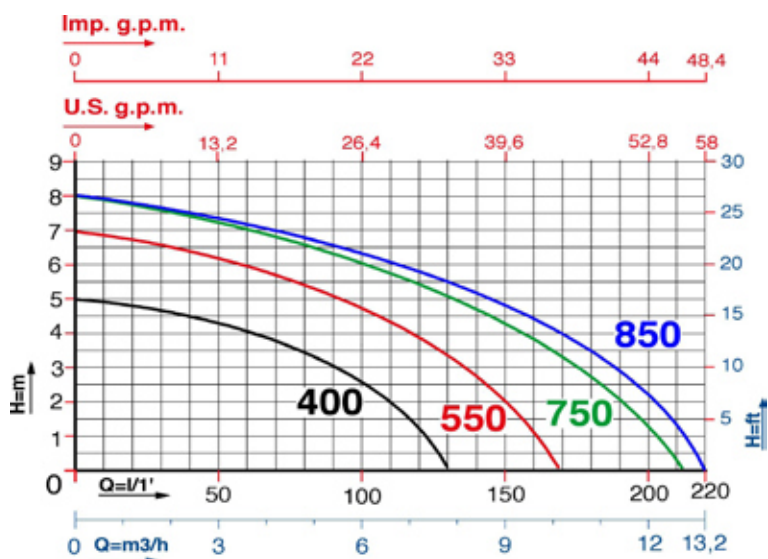

CARATTERISTICHE COSTRUTTIVE:

Corpo pompa: TECNOPOLIMERO
Motore: Raffreddato ad acqua
Albero motore: Acciaio inox AISI
Classe isolamento: B
Classe protezione: IP 68
Tenuta: Paraoli ad alta resistenza
Utilizzo: Intermittente

MAIN FEATURES:

Pump body: PP30FV
Motor: Water cooled
Motor shaft: Stainless steel
Insulation class: B
Protection class: IP 68
Seal: High resistant lip seals
Duty: Intermittant

DATI ELETTRICI / ELECTRICAL DATA						IMBALLO / PACKAGING			
TYPE	HP (P2)	kW (P2)	DNM	r.p.m.	Temp Max	L	N	M	Kg
VXP 400	0,55	0,4	1" 1"1/2 1"1/4	2800	30°C	220	390	175	4,0
VXP 550	0,75	0,55		2800	30°C	220	390	175	4,6
VXP 750	1	0,75		2800	30°C	220	390	175	5,0
VXP 850	1	0,85		2800	30°C	220	390	175	5,6

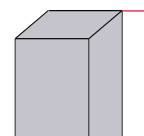

POMPE SOMMERSIBILI IN PLASTICA
PLASTIC SUBMERSIBLE PUMPS

PMF



ELETTROPOMPE PERIFERICHE PERIPHERAL ELECTRIC PUMPS

APREVALENZA : 34 mt. ÷ 93 mt.
PORTATA : 2,4 m³/h ÷ 4,2 m³/h
POTENZA NOMINALE : 0,37 kW (0,5HP) ÷ 1,5 kW (2,0HP)

PUMP HEAD : 34,0 mt ÷ 93,0 mt
DELIVERY : 2,4 m³/h ÷ 4,2 m³/h
RATED HORSEPOWER : 0,37 kW (0,5HP) ÷ 1,5 kW (2,0HP)

APPLICAZIONI

- PRESSURIZZAZIONE DI IMPIANTI DOMESTICI E PICCOLA IRRIGAZIONE.
- MOVIMENTAZIONE DI LIQUIDI NON AGGRESSIVI PER USI CIVILI ED INDUSTRIALI.
- IMPIANTI DI LAVAGGIO, INSERIMENTO SU MACCHINARI PIU' COMPLESSI PER USI INDUSTRIALI.

APPLICATIONS

- FOR DOMESTIC SYSTEMS AND SMALL IRRIGATION SYSTEM PRESSURISATION.
- HANDLING OF NON AGGRESSIVE CIVIL AND INDUSTRIAL LIQUIDS.
- FOR WASHING SYSTEMS AND FOR INSERTION INTO COMPLEX INDUSTRIAL MACHINERY AND LINES.



CARATTERISTICHE DI COSTRUZIONE:

- MOTORE CHIUSO CON VENTILAZIONE ESTERNA E CASSA ALETTATA IN LEGA DI ALLUMINIO.
- GRADO DI PROTEZIONE IP 44.
- CLASSE DI ISOLAMENTO: F.
- TEMPERATURA MAX. LIQUIDO POMPATO: 35°C.
- VERSIONI: Monofase: 220-230V/50Hz o 220-230V/60Hz con protettore termico incorporato e condensatore permanentemente inserito.
Trifase: 220-230V/50Hz e 380-400V/50Hz o 220-230V/60Hz e 380-400V/60Hz con protezione da sovraccarico a cura dell'utente.
- POTENZA MOTORE: DA 0,5 Hp a 1,0 Hp SOLO VERSIONE MONOFASE.
DA 1,5 Hp a 2,0 Hp VERSIONE MONOFASE E TRIFASE.

SPECIALI VOLTAGGI E FREQUENZE A RICHIESTA.

DESIGN ENGINEERING:

- SEALED MOTOR WITH EXTERNAL VENTILATION AND FINNED ALUMINIUM ALLOY CASING.
- IP 44 PROTECTION CLASS.
- CLASS "F" INSULATION.
- MAX. PUMPED LIQUID TEMPERATURE: 35°C.
- VERSIONS: Single Phase: 220-230V/50Hz or 220-230V/60Hz with built in thermal protector and permanent capacitor.
Three Phase: 220-230V/50Hz and 380-400V/50Hz or 220-230V/60Hz and 380-400V/60Hz with overload protection care of the User.
- MOTOR POWER: From 0.5 Hp to 1.0 Hp only single phase versions.
From 1.5 Hp to 2.0 Hp single phase versions and three phases versions.

CUSTOMISED VOLTAGE AND FREQUENCY RATING AVAILABLE ON DEMAND.

TABELLA MATERIALI / MATERIALS TABLE:

Pos.	Componente / Component	Materiale / Materials
A	Corpo pompa / Pump body	GHISA / CAST IRON
B	Girante / Impeller	OTTONE / BRASS
C	Tenuta meccanica / Mechanical Seal	CERAMICA-GRAFITE / CERAMIC-GRAPHITE
D	Flangia / Flange	GHISA / CAST IRON
E	Albero (lato pompa) / Shaft (pump face)	ACCIAIO INOX / STAINLESS STEEL

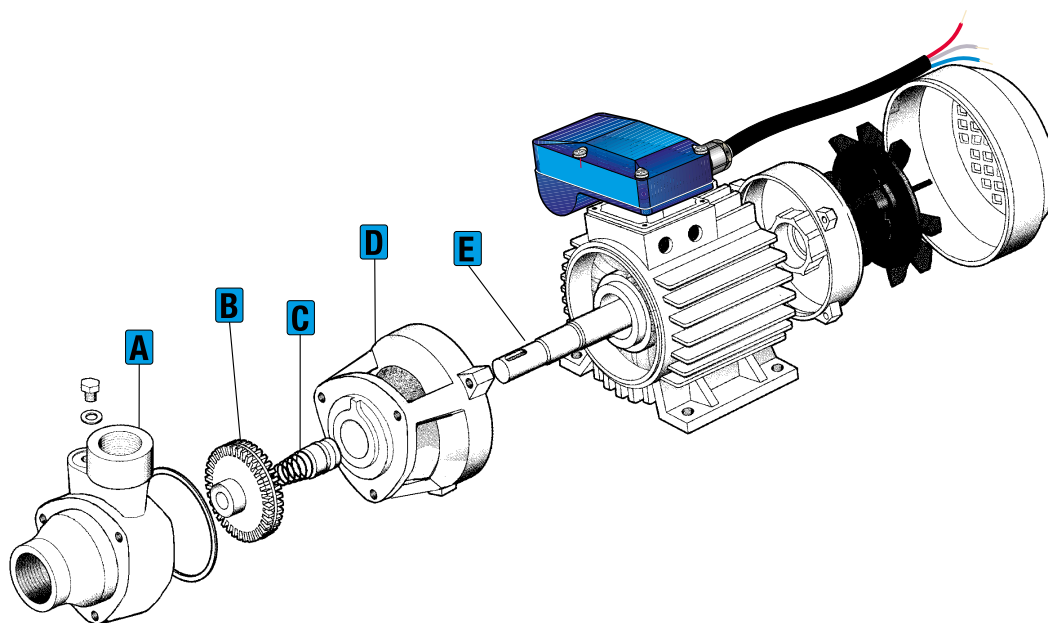

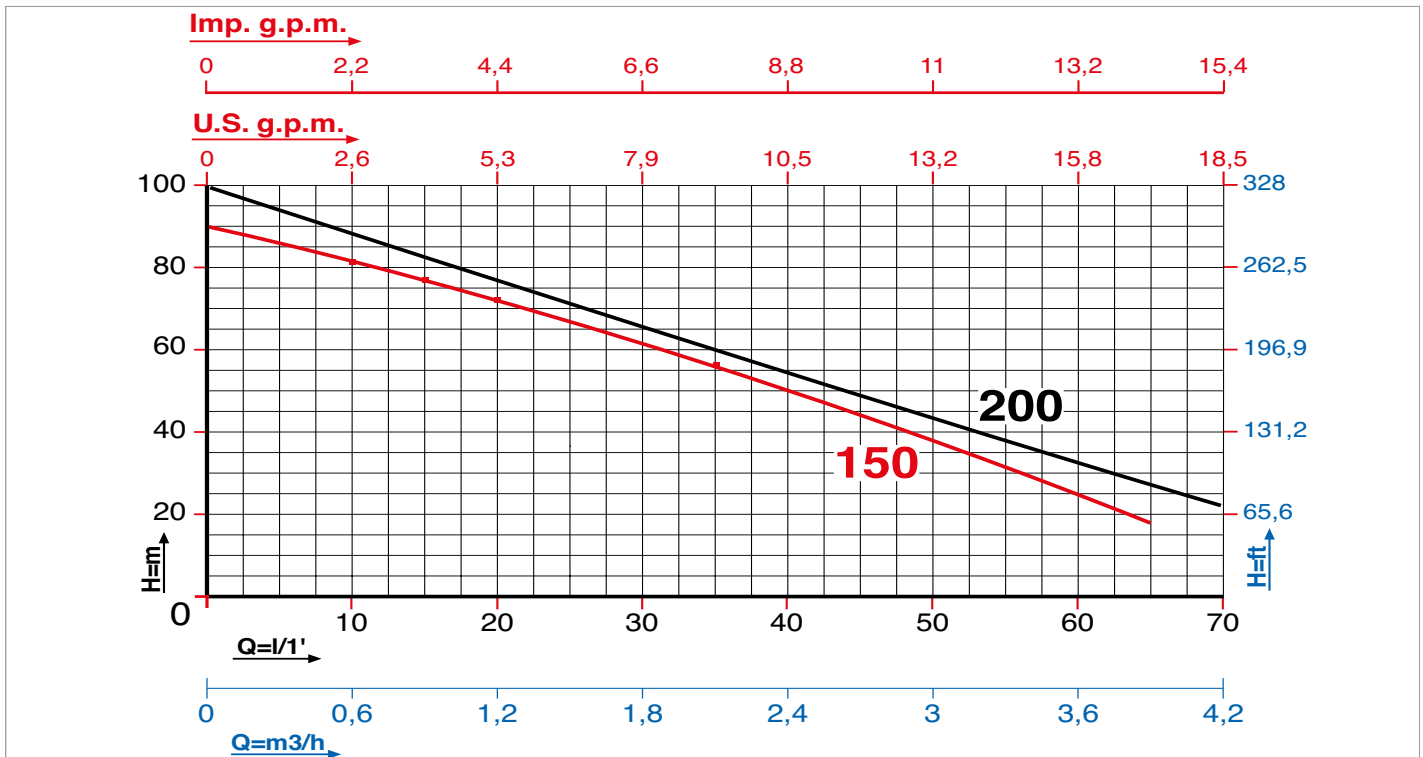
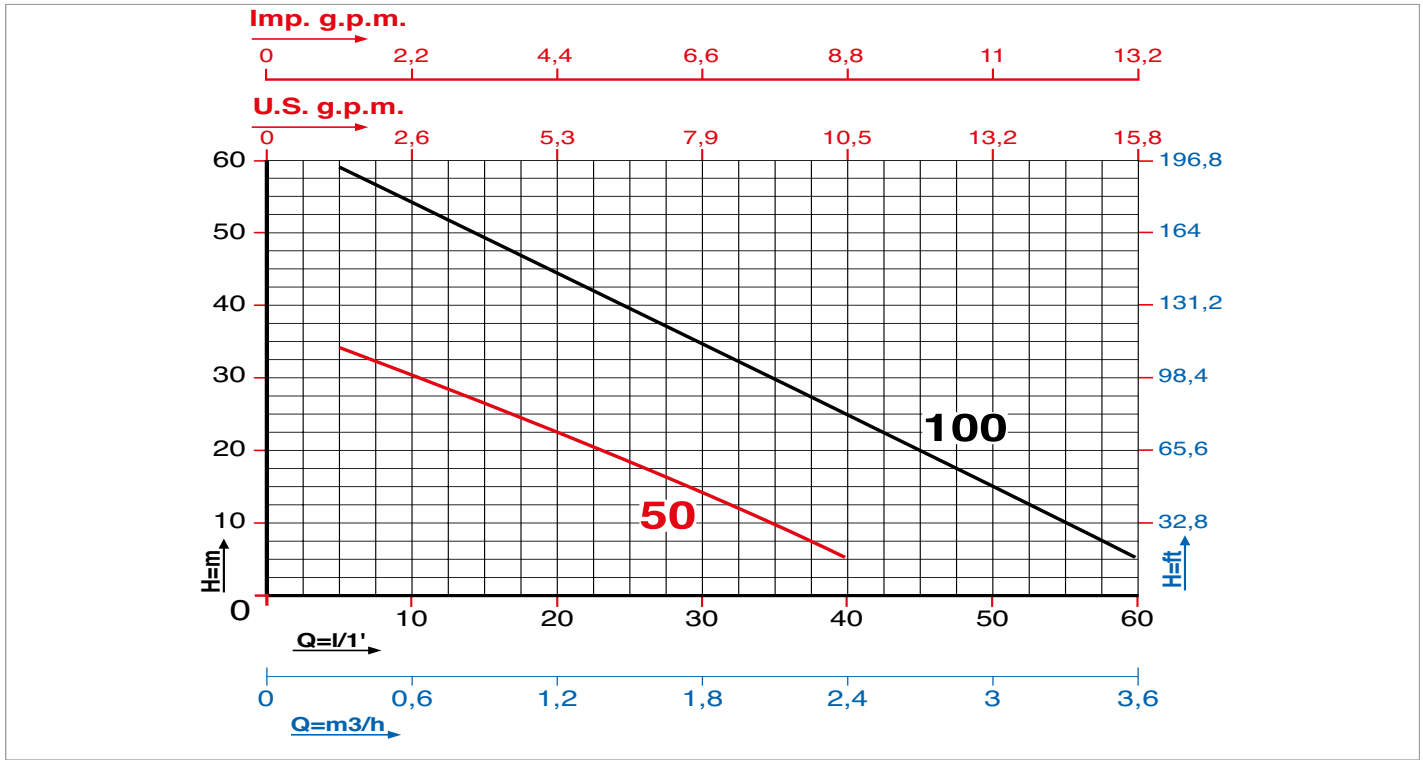

Caratteristiche di funzionamento a 2800 rpm 50Hz e 3450 rpm 60Hz - Performances at 2800 rpm 50 Hz and 3450 rpm 60 Hz
 Le prestazioni valgono per liquidi con densità $\rho = 1,0 \text{ kg/dm}^3$ ed una viscosità $\nu = 1 \text{ mm}^2/\text{s}$ / The performance data holds true for liquids with a $\rho = 1,0 \text{ kg/dm}^3$ density and a $\nu = 1 \text{ mm}^2/\text{s}$ viscosity.

MODELLO MODEL	VOLTAGGIO VOLTAGE	DATI ELETTRICI / ELECTRICAL DATA					DATI IDRAULICI / HYDRAULIC DATA												
		P1max	P2 nom.	I max	Condensatore Capacitor		m³/h	0,3	0,6	1,2	1,5	1,8	2,4	3,0	3,6	3,9	4,2		
	50 Hz	kW	kW	HP	Ampere	µF	VC	l/min.	5	10	20	25	30	40	50	60	65	70	
PMF 50 M	1 x 220-230V	0,55	0,37	0,5	2,9	10,0	450	H (m)	34,0	30,0	22,0	17,0	13,0	5,0	---	---	---	---	
PMF 100 M	1 x 220-230V	0,9	0,75	1,0	3,8	16,0	450		59,0	55,0	45,0	40,0	35,0	25,0	15,0	5,0	---	---	---
PMF 150 M	1 x 220-230V	1,1	1,1	1,5	10,0	35,0	450		83,0	81,0	72,0	67,0	61,5	50,0	38,0	22,0	18,0	---	---
PMF 150 T	3 x 380-440V	1,1	1,1	1,5	3,6	---	---		83,0	81,0	72,0	67,0	61,5	50,0	38,0	22,0	18,0	---	---
PMF 200 M	1 x 220-230V	1,5	1,5	2,0	10,9	40,0	450		93,0	88,0	77,0	71,5	62,5	57,0	43,5	37,5	27,5	22,0	---
PMF 200 T	3 x 380-440V	1,5	1,5	2,0	4,0	---	---		93,0	88,0	77,0	71,5	62,5	57,0	43,5	37,5	27,5	22,0	---

PREVALENZA TOTALE in METRI COLONNA ACQUA / TOTAL PUMP HEAD AND WATER COLUMN HEIGHT IN m.

DIMENSIONI e PESI / SIZE AND WEIGHT DATA :

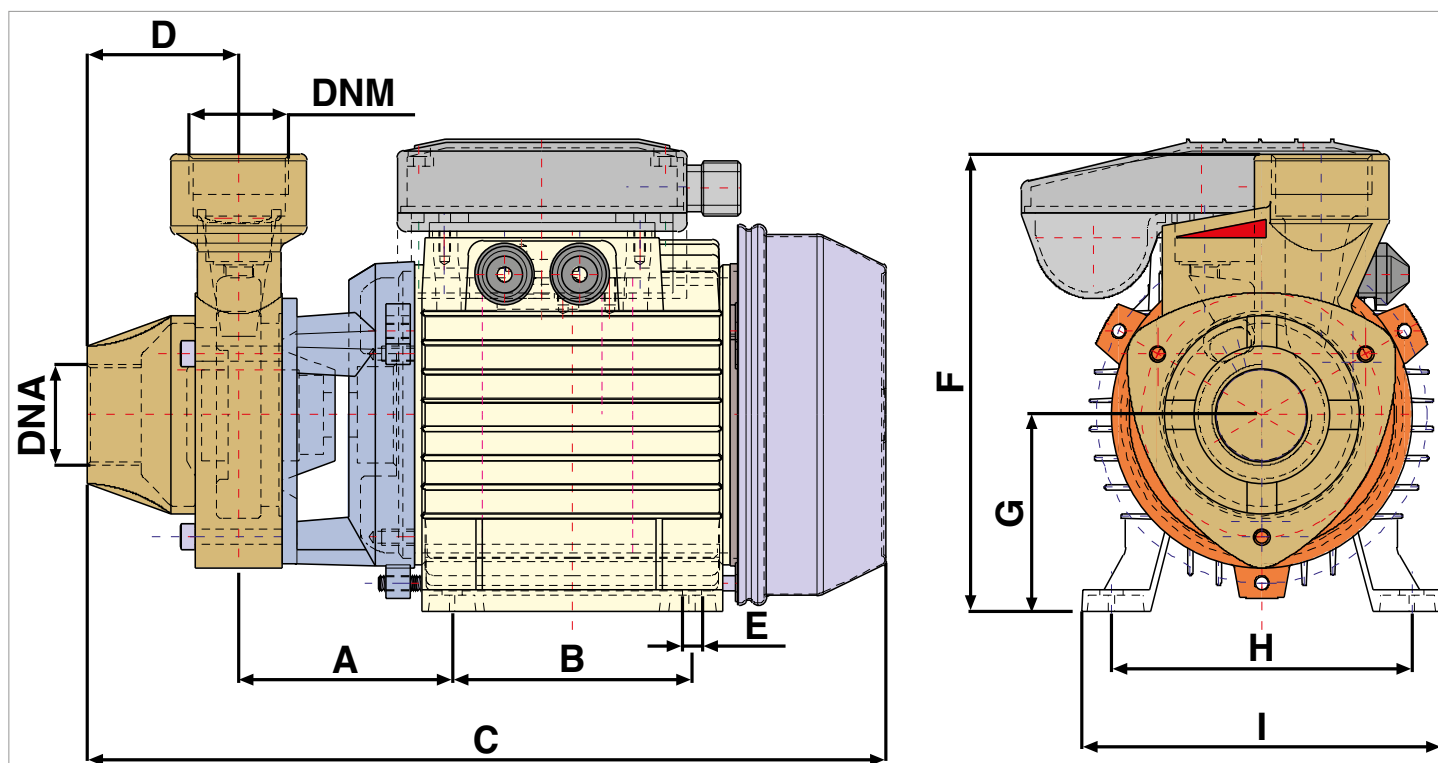
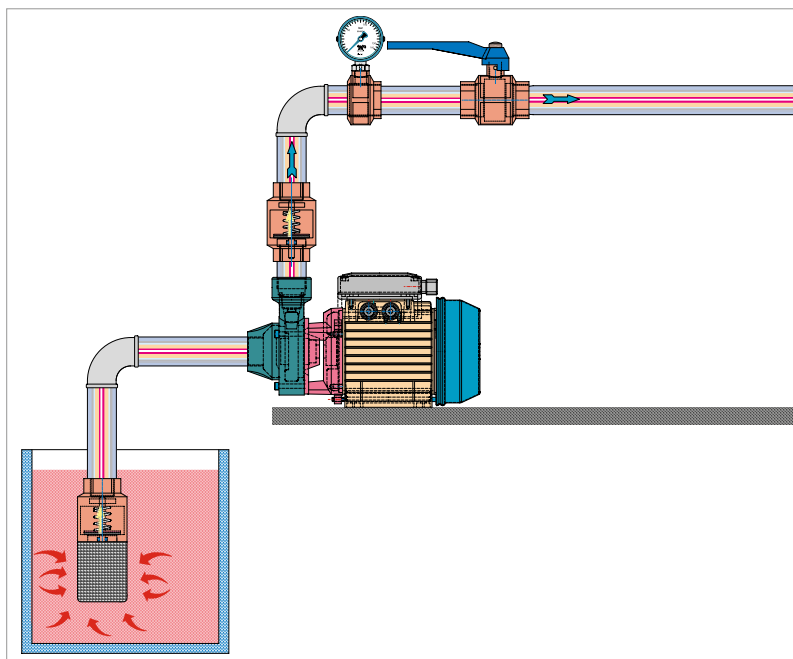
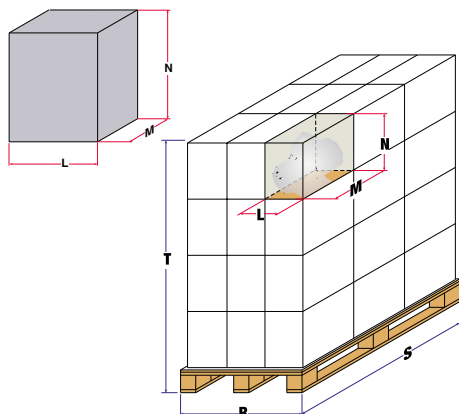

MODELLO / MODEL	DIMENSIONI POMPA in mm. / PUMP DIMENSIONS in mm.										
	DNA	DNM	A	B	C	D	E	F	G	H	I
PMF 50	1"	1"	65	80	255	20	7	144	63	100	120
PMF 100	1"	1"	70	90	295	20	7	161	71	112	135
PMF 150	1"	1"	88	100	330,5	57	9	212	80	125	152
PMF 200	1"	1"	88	100	330,5	57	9	212	80	125	152

MODELLO MODEL	DIMENSIONI SCATOLA / PACKING DIMENSIONS			
	L mm	M mm	N mm	Peso / Weight Kg
PMF 50	170	285	170	6,5
PMF 100	175	325	190	9,2
PMF 150	210	385	255	14,5
PMF 200	210	385	255	15,8

JET



ELETTROPOMPE AUTOADESCANTI CON UNA GIRANTE SELF-PRIMING ELECTRIC PUMPS WITH ONE IMPELLER

PREVALENZA : 38 mt. ÷ 47 mt.
PORTATA : 3,6 m³/h - 9 m³/h
POTENZA NOMINALE : 0,6 kW (0,8HP) ÷ 1,5 kW (2HP)

PUMP HEAD : 38,0 mt ÷ 47,0 mt
DELIVERY : 3,6 m³/h ÷ 9,0 m³/h
RATED HORSEPOWER : 0,6 kW (0,8HP) ÷ 1,5 kW (2,0HP)

APPLICAZIONI

- PRESSURIZZAZIONE DI IMPIANTI DOMESTICI E PICCOLA IRRIGAZIONE.
- MOVIMENTAZIONE DI LIQUIDI NON AGGRESSIVI PER USI CIVILI ED INDUSTRIALI.
- IMPIANTI DI LAVAGGIO, INSERIMENTO SU MACCHINARI PIU' COMPLESSI PER USI INDUSTRIALI.
- IMPIANTI DOVE E' NECESSARIO L'AUTOADESCAMENTO.

APPLICATIONS

- FOR DOMESTIC SYSTEMS AND SMALL IRRIGATION SYSTEM PRESSURISATION.
- HANDLING OF NON AGGRESSIVE CIVIL AND INDUSTRIAL LIQUIDS.
- FOR WASHING SYSTEMS AND FOR INSERTION INTO COMPLEX INDUSTRIAL MACHINERY AND LINES.
- FOR ANY APPLICATION REQUIRING A SELF PRIMING SYSTEM.



ARVEN[®]
WATER ■ PUMPS

CARATTERISTICHE DI COSTRUZIONE:

- MOTORE CHIUSO CON VENTILAZIONE ESTERNA E CASSA ALETTATA IN LEGA DI ALLUMINIO
- GRADO DI PROTEZIONE IP 44.
- CLASSE DI ISOLAMENTO: F.
- TEMPERATURA MAX.LIQUIDO POMPATO: 35°C.
- VERSIONI: Monofase: 220 - 230V/50Hz o 220 - 230V/60Hz con protettore termico incorporato e condensatore permanentemente inserito.
Trifase: 220 - 230V/50Hz e 380 - 400V/50Hz o 220 - 230V/60Hz e 380 - 400V/60Hz con protezione da sovraccarico a cura dell'utente
- POTENZA MOTORE: DA 0,8 Hp a 2 Hp VERSIONE MONOFASE E TRIFASE.

SPECIALI VOLTAGGI E FREQUENZE A RICHIESTA.

DESIGN ENGINEERING:

- SEALED MOTOR WITH EXTERNAL VENTILATION AND FINNED ALUMINIUM ALLOY CASING.
- IP 44 PROTECTION CLASS.
- CLASS "F" INSULATION.
- MAX. PUMPED LIQUID TEMPERATURE: 35°C.
- VERSIONS: Single Phase: 220 - 230 V/50 Hz or 220 - 230V/60 Hz with built in thermal protection and permanent capacitor.
Three Phase : 220 - 230V/50Hz and 380 - 400V/50Hz or 220 - 230V/60Hz and 380- 400V/60Hz with overload protection care of the User.
- MOTOR POWER: From 0.8 Hp to 2 Hp single phase and three phases versions.

CUSTOMISED VOLTAGE AND FREQUENCY RATING AVAILABLE ON DEMAND.

TABELLA MATERIALI / MATERIALS TABLE:

Pos.	Componente / Component	Materiale / Materials	
A	Corpo pompa / Pump body	GHISA / CAST IRON	
B	Diffusore / Diffuser	NORYL	
C	Girante / Impeller	JET 90	NORYL
		JET 100	ACCIAIO INOX / STAINLESS STEEL
		JET 150-200	OTTONE / BRASS
D	Tenuta meccanica / Mechanical Seal	CERAMICA-GRAFITE / CERAMIC-GRAPHITE	
E	Flangia / Flange	JET 90-100	ALLUMINIO / ALUMINIUM
		JET 150-200	GHISA / CAST IRON
F	Albero (lato pompa) / Shaft (pump face)	ACCIAIO INOX / STAINLESS STEEL	

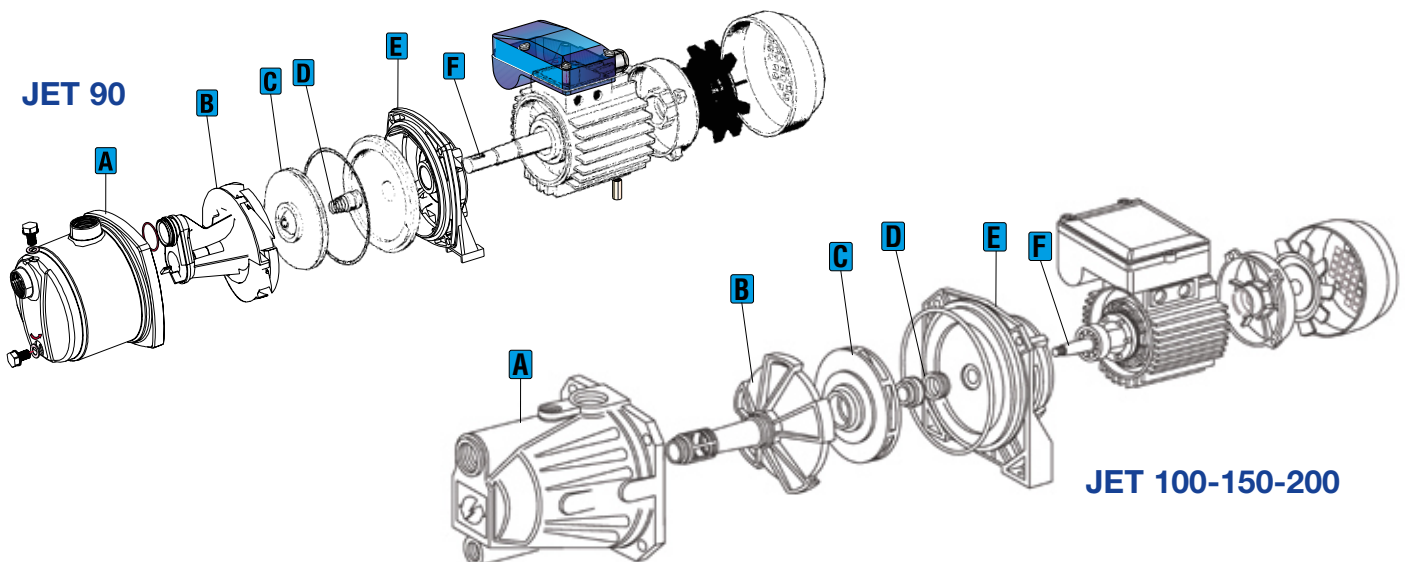

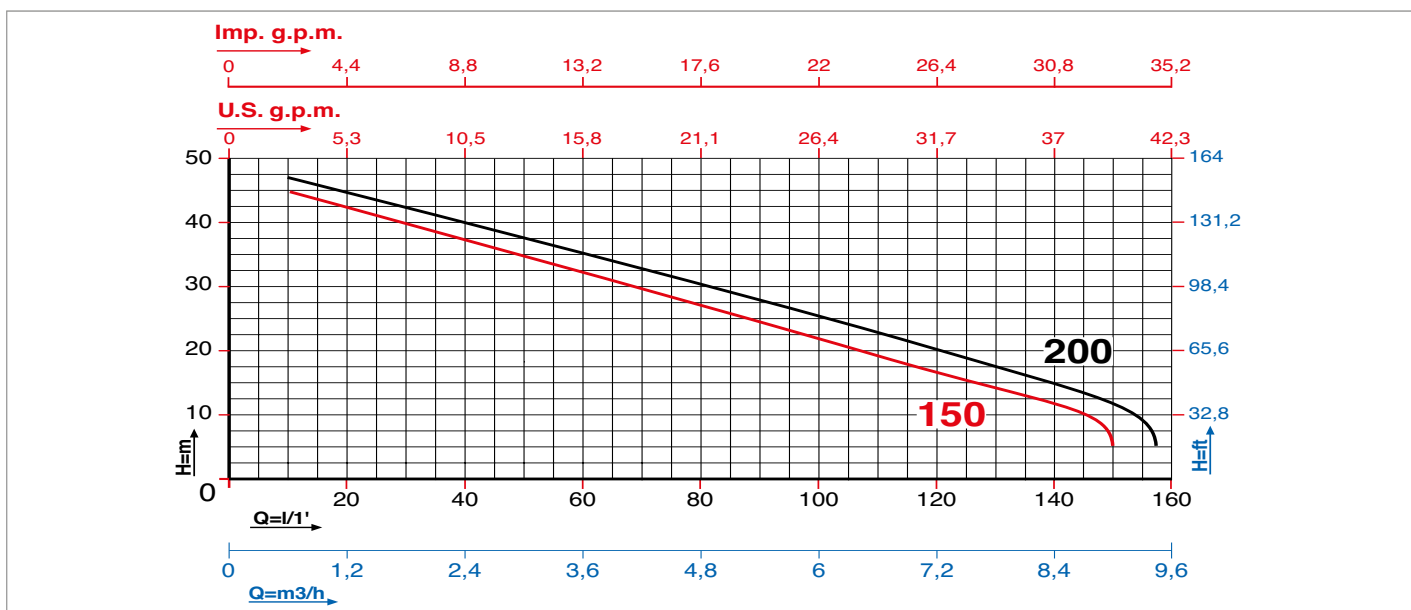
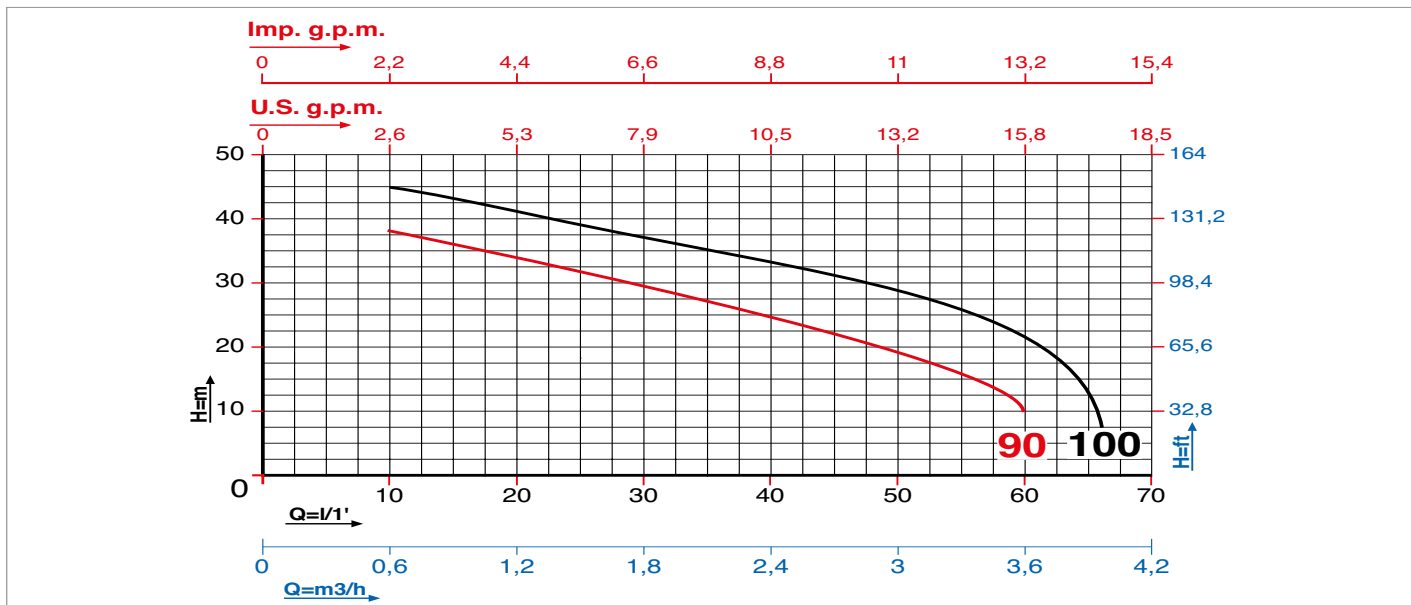

Caratteristiche di funzionamento a 2800 rpm 50Hz e 3450 rpm 60Hz - Performances at 2800 rpm 50 Hz and 3450 rpm 60 Hz
 Le prestazioni valgono per liquidi con densità $\rho = 1,0 \text{ kg/dm}^3$ ed una viscosità $\nu = 1 \text{ mm}^2/\text{s}$ / The performance data holds true for liquids with a $\rho = 1,0 \text{ kg/dm}^3$ density and a $\nu = 1 \text{ mm}^2/\text{s}$ viscosity.

MODELLO MODEL	VOLTAGGIO VOLTAGE	DATI ELETTRICI / ELECTRICAL DATA						DATI IDRAULICI / HYDRAULIC DATA										
		P1max	P2 nom.	I max	Condensatore Capacitor			m³/h	0,6	1,2	1,8	2,4	3	3,6	4	5,4	6	9
	50 Hz	kW	kW	HP	Ampere	µF	VC	l/min.	10	20	30	40	50	60	66	90	100	150
JET 90 M	1 x 220-230V	0,8	0,6	0,8	3,8	12,5	450	H (m)	38,0	34,0	29,0	25,0	19,0	10,0	---	---	---	---
JET 90 T	3 x 380-440V	0,8	0,6	0,8	1,9	---	---		38,0	34,0	29,0	25,0	19,0	10,0	---	---	---	---
JET 100 M	1 x 220-230V	1,1	0,75	1,0	5,0	20,0	450		45,0	40,0	35,0	30,0	26,0	22,0	7,0	---	---	---
JET 100 T	3 x 380-440V	1,1	0,75	1,0	2,5	---	---		45,0	40,0	35,0	30,0	26,0	22,0	7,0	---	---	---
JET 150 M	1 x 220-230V	1,5	1,1	1,5	7,0	40,0	450		45,0	42,0	40,0	37,5	34,5	33,0	30,5	25,0	22,0	10,0
JET 150 T	3 x 380-440V	1,5	1,1	1,5	3,0	---	---		45,0	42,0	40,0	37,5	34,5	33,0	30,5	25,0	22,0	10,0
JET 200 M	1 x 220-230V	2,0	1,5	2,0	9,3	40,0	450		47,0	45,0	43,0	40,0	37,5	35,0	33,0	27,0	18,0	13,0
JET 200 T	3 x 380-440V	2,0	1,5	2,0	4,2	---	---		47,0	45,0	43,0	40,0	37,5	35,0	33,0	27,0	18,0	13,0

PREVALENZA TOTALE in METRI COLONNA ACQUA / TOTAL PUMP HEAD AND WATER COLUMN HEIGHT IN m.

DIMENSIONI e PESI / SIZE AND WEIGHT DATA:

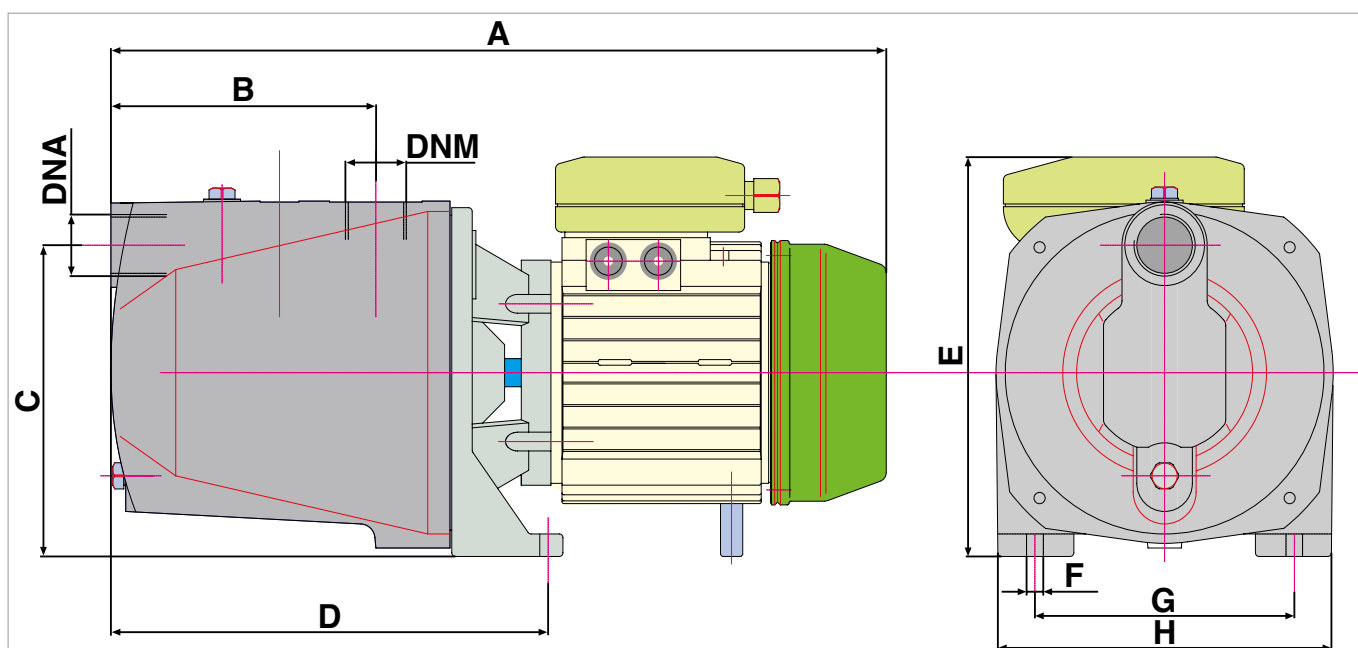
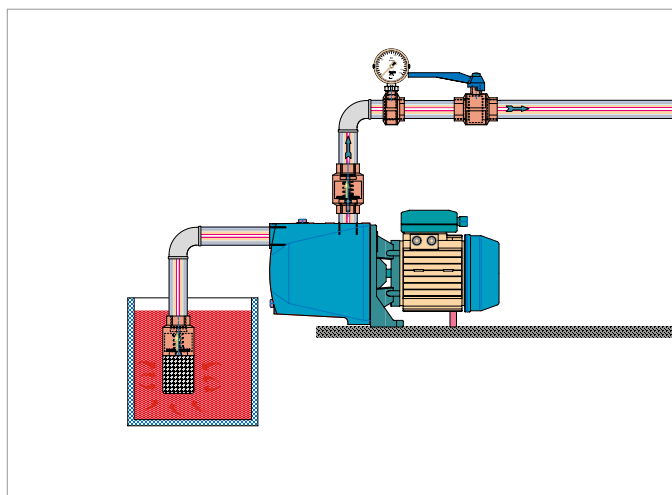
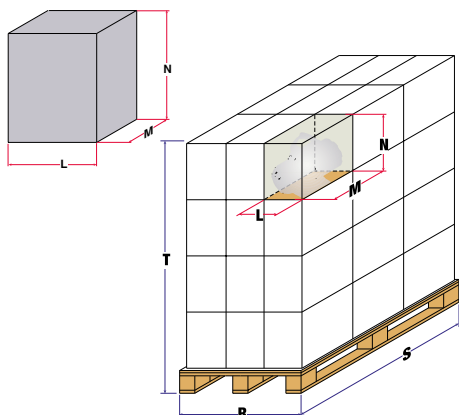

MODELLO / MODEL	DIMENSIONI POMPA in mm. / PUMP DIMENSIONS in mm.									
	DNA	DNM	A	B	C	D	E	F	G	H
JET 90	1"	1"	328	77	123	150	193	9	126	162
JET 100	1"	1"	421	145	156	211	194	9	140	176
JET 150	1" 1/4	1"	570	171	198	282	271	12	198	236
JET 200	1" 1/4	1"	570	171	198	282	271	12	198	236

MODELLO MODEL	DIMENSIONI SCATOLA / PACKING DIMENSIONS			
	L mm	M mm	N mm	Peso / Weight Kg
JET 90	350	180	200	9,0
JET 100	450	200	210	15,0
JET 150	590	255	280	38,0
JET 200	590	255	280	40,0

JETX



ELETTROPOMPE AUTOADESCANTI CON UNA GIRANTE SELF-PRIMING ELECTRIC PUMPS WITH ONE IMPELLER

PREVALENZA : 36 mt. ÷ 61 mt.
PORTATA : 3 m³/h - 3,6 m³/h
POTENZA NOMINALE : 0,5 Kw (0,7HP) ÷ 0,9 Kw (2,2HP)

PUMP HEAD : 36,0 mt ÷ 61,0 mt
DELIVERY : 3,0 m³/h ÷ 3,6 m³/h
RATED HORSEPOWER : 0,5 kW (0,7HP) ÷ 0,9 kW (1,2HP)

APPLICAZIONI

- PRESSURIZZAZIONE DI IMPIANTI DOMESTICI E PICCOLA IRRIGAZIONE.
- MOVIMENTAZIONE DI LIQUIDI NON AGGRESSIVI PER USI CIVILI ED INDUSTRIALI.
- IMPIANTI DI LAVAGGIO, INSERIMENTO SU MACCHINARI PIU' COMPLESSI PER USI INDUSTRIALI.
- IMPIANTI DOVE E' NECESSARIO L'AUTOADESCAMENTO.

APPLICATIONS

- FOR DOMESTIC SYSTEMS AND SMALL IRRIGATION SYSTEM PRESSURISATION.
- HANDLING OF NON AGGRESSIVE CIVIL AND INDUSTRIAL LIQUIDS.
- FOR WASHING SYSTEMS AND FOR INSERTION INTO COMPLEX INDUSTRIAL MACHINERY AND LINES.
- FOR ANY APPLICATION REQUIRING A SELF PRIMING SYSTEM.



CARATTERISTICHE DI COSTRUZIONE:

- MOTORE CHIUSO CON VENTILAZIONE ESTERNA E CASSA ALETTATA IN LEGA DI ALLUMINIO
- GRADO DI PROTEZIONE IP 44.
- CLASSE DI ISOLAMENTO: F
- TEMPERATURA MAX.LIQUIDO POMPATO: 35°C
- VERSIONI: Monofase: 220 - 230V/50Hz o 220 - 230V/60Hz con protettore termico incorporato e condensatore permanentemente inserito.
Trifase: 220 - 230V/50Hz e 380 - 400V/50Hz o 220 - 230V/60Hz e 380 - 400V/60Hz con protezione da sovraccarico a cura dell'utente
- POTENZA MOTORE: 0,7 Hp solo VERSIONE MONOFASE.
0,9 Hp a 1,2 Hp VERSIONE MONOFASE E TRIFASE

SPECIALI VOLTAGGI E FREQUENZE A RICHIESTA.

DESIGN ENGINEERING:

- SEALED MOTOR WITH EXTERNAL VENTILATION AND FINNED ALUMINIUM ALLOY CASING.
- IP 44 PROTECTION CLASS.
- CLASS "F" INSULATION
- MAX. PUMPED LIQUID TEMPERATURE: 35°C
- VERSIONS: Single Phase: 220 - 230 V/50 Hz or 220 - 230V/60 Hz with built in thermal protection and permanent capacitor.
Three Phase : 220 - 230V/50Hz and 380 - 400V/50Hz or 220 - 230V/60Hz and 380- 400V/60Hz with overload protection care of the User.
- MOTOR POWER: 0.7 Hp only single phase versions.
0.9 Hp to 1,2Hp single phase and three phase version

CUSTOMISED VOLTAGE AND FREQUENCY RATING AVAILABLE ON DEMAND.

TABELLA MATERIALI / MATERIALS TABLE:

Pos.	Componente / Component	Materiale / Materials
A	Corpo pompa / Pump body	GHISA / CAST IRON
B	Diffusore / Diffuser	NORYL
C	Girante / Impeller	JETX 90
		JET 100
D	Tenuta meccanica / Mechanical Seal	CERAMICA-GRAFITE / CERAMIC-GRAPHITE
E	Flangia / Flange	ALLUMINIO / ALUMINIUM
F	Albero (lato pompa) / Shaft (pump face)	ACCIAIO INOX / STAINLESS STEEL

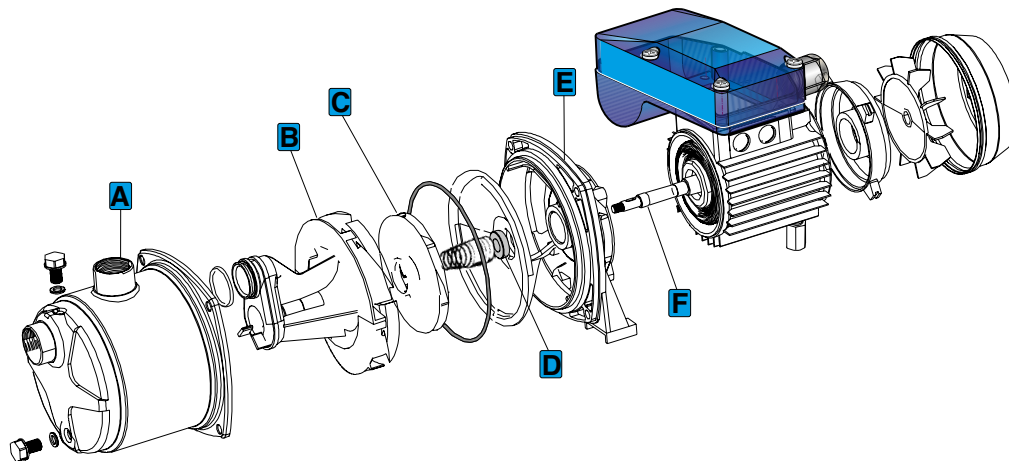

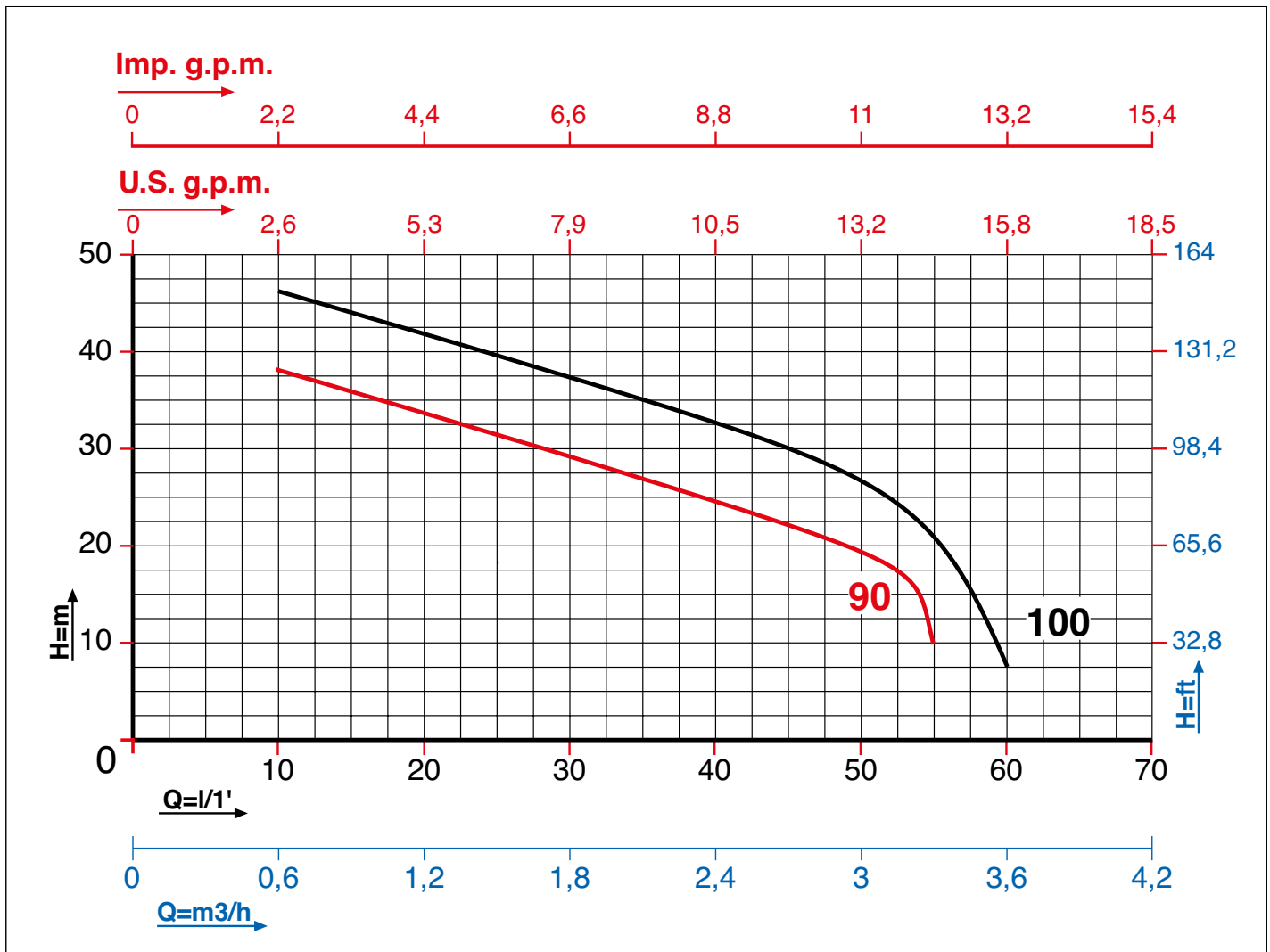

Caratteristiche di funzionamento a 2800 rpm 50Hz e 3450 rpm 60Hz - Performances at 2800 rpm 50 Hz and 3450 rpm 60 Hz
 Le prestazioni valgono per liquidi con densità $\rho = 1,0 \text{ kg/dm}^3$ ed una viscosità $\nu = 1 \text{ mm}^2/\text{s}$ / The performance data holds true for liquids with a $\rho = 1,0 \text{ kg/dm}^3$ density and a $\nu = 1 \text{ mm}^2/\text{s}$ viscosity.

MODELLO MODEL	VOLTAGGIO VOLTAGE	DATI ELETTRICI / ELECTRICAL DATA						DATI IDRAULICI / HYDRAULIC DATA											
		P1 max		P2 nom.		I max	Condensatore Capacitor		m ³ /h	0,6	0,9	1,2	1,5	1,8	2,1	2,4	3	3,3	3,6
		kW	kW	HP	Ampere	µF	VC	l/min.	10	15	20	25	30	35	40	50	55	60	
JETX 90 M	1 x 220-230V	0,8	0,6	0,8	3,8	12,5	450	H (m)	38,0	36,0	34,0	32,0	29,0	27,0	24,0	19,0	10,0	---	
JETX 90 T	3 x 380-440V	0,8	0,6	0,8	1,9	---	---		38,0	36,0	34,0	32,0	29,0	27,0	24,0	19,0	10,0	---	
JETX 100 M	1 x 220-230V	1,1	0,75	1,0	4,0	20,0	450		46,0	43,0	40,0	38,0	35,0	32,0	30,0	26,0	20,5	10,0	
JETX 100 T	3 x 380-440V	1,1	0,75	1,0	2,1	---	---		46,0	43,0	40,0	38,0	35,0	32,0	30,0	26,0	20,5	10,0	

PREVALENZA TOTALE in METRI COLONNA ACQUA / TOTAL PUMP HEAD AND WATER COLUMN HEIGHT IN m.

DIMENSIONI e PESI / SIZE AND WEIGHT DATA:

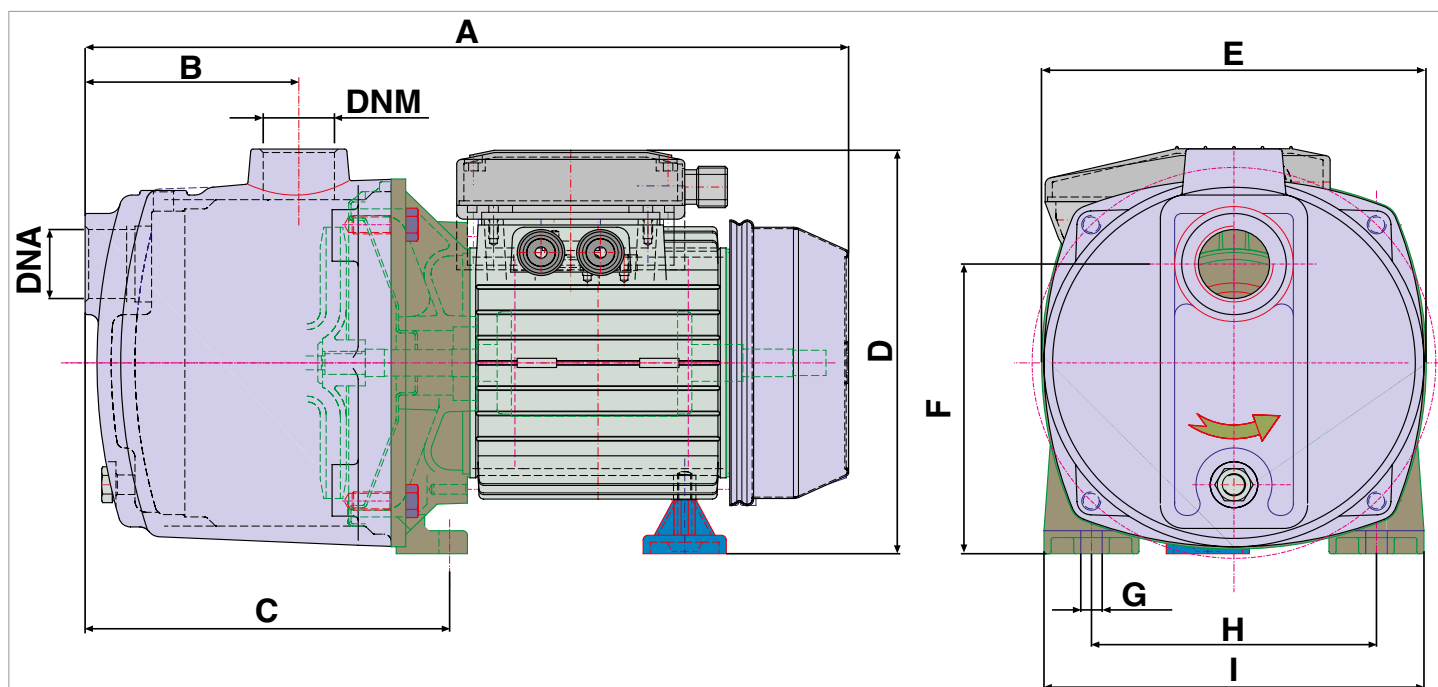
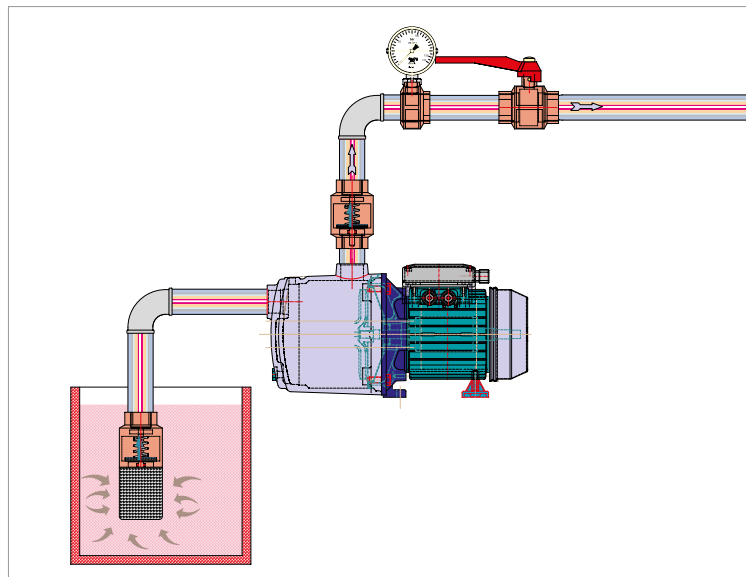
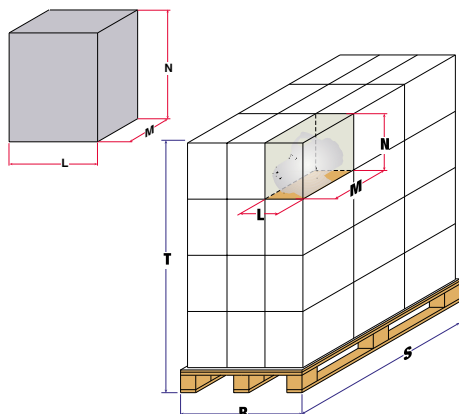

MODELLO / MODEL	DIMENSIONI POMPA in mm. / PUMP DIMENSIONS in mm.										
	DNA	DNM	A	B	C	D	E	F	G	H	I
JETX 90	1"	1"	320	72	163	180	166	123	9	126	162
JETX 100	1"	1"	370	81	163	200	184	149	9	140	176

MODELLO MODEL	DIMENSIONI SCATOLA / PACKING DIMENSIONS			
	L mm	M mm	N mm	Peso / Weight Kg
JETX 90	360	180	200	7,0
JETX 100	420	190	230	8,5

R



ELETTROPOMPE CENTRIFUGHE CON UNA GIRANTE CENTRIFUGAL ELECTRIC PUMPS WITH ONE IMPELLER

PREVALENZA : 20 mt. ÷ 54 mt.
PORTATA : 6 m³/h ÷ 9 m³/h.
POTENZA NOMINALE : 0,37 kW (0,5HP) ÷ 2,2 kW (3HP)

PUMP HEAD : 20,0 mt ÷ 54,0 mt
DELIVERY : 6,0 m³/h ÷ 9,0 m³/h
RATED HORSEPOWER : 0,37 kW (0,5HP) ÷ 2,2 kW (3,0HP)

APPLICAZIONI

- PRESSURIZZAZIONE DI IMPIANTI DOMESTICI E PICCOLA IRRIGAZIONE.
- MOVIMENTAZIONE DI LIQUIDI NON AGGRESSIVI PER USI CIVILI ED INDUSTRIALI.
- IMPIANTI DI LAVAGGIO, INSERIMENTO SU MACCHINARI PIU' COMPLESSI PER USI INDUSTRIALI.

APPLICATIONS

- FOR DOMESTIC SYSTEMS AND SMALL IRRIGATION SYSTEM PRESSURISATION.
- HANDLING OF NON AGGRESSIVE CIVIL AND INDUSTRIAL LIQUIDS.
- FOR WASHING SYSTEMS AND FOR INSERTION INTO COMPLEX INDUSTRIAL MACHINERY AND LINES.



ARVEN[®]
WATER PUMPS

CARATTERISTICHE DI COSTRUZIONE:

- MOTORE CHIUSO CON VENTILAZIONE ESTERNA E CASSA ALETTATA IN LEGA DI ALLUMINIO.
- GRADO DI PROTEZIONE IP 44 (R 50-75-100).
- GRADO DI PROTEZIONE IP 55 (R 150-200-300).
- CLASSE DI ISOLAMENTO: F.
- TEMPERATURA MAX.LIQUIDO POMPATO: 35°C.
- VERSIONI: Monofase: 220 - 230V/50Hz o 220 - 230V/60Hz con protettore termico incorporato e condensatore permanentemente inserito.
Trifase: 220 - 230V/50Hz e 380 - 400V/50Hz o 220 - 230V/60Hz e 380-400V/60Hz con protezione da sovraccarico a cura dell'utente.
- POTENZA MOTORE: da 0,5 Hp ÷ 3 Hp VERSIONE MONOFASE E TRIFASE.

SPECIALI VOLTAGGI E FREQUENZE A RICHIESTA.

DESIGN ENGINEERING:

- SEALED MOTOR WITH EXTERNAL VENTILATION AND FINNED ALUMINIUM ALLOY CASING.
- IP 44 PROTECTION CLASS (R 50-75-100).
- IP 55 PROTECTION CLASS (R 150-200-300).
- CLASS "F" INSULATION.
- MAX. PUMPED LIQUID TEMPERATURE: 35°C.
- VERSIONS: Single Phase: 220 - 230 V/50 Hz or 220 - 230V/60 Hz with built in thermal protection and permanent capacitor.
Three Phase : 220 - 230V/50Hz and 380 - 400V/50Hz or 220 - 230V/60Hz and 380- 400V/60Hz with overload protection care of the User.
- MOTOR POWER: From 0.5 Hp to 3 Hp single phase and three phase versions.

CUSTOMISED VOLTAGE AND FREQUENCY RATING AVAILABLE ON DEMAND.

TABELLA MATERIALI / MATERIALS TABLE:

Pos.	Componente / Component	Materiale / Materials
A	Corpo pompa / Pump body	GHISA / CAST IRON
B	Girante / Impeller	R 50-75-100 NORYL
		R 150-200-300 OTTONE / BRASS
C	Tenuta meccanica / Mechanical Seal	CERAMICA-GRAFITE / CERAMIC-GRAPHITE
D	Flangia / Flange	R 50-75-100 ALLUMINIO / ALUMINIUM
		R 150-200-300 GHISA / CAST IRON
E	Albero (lato pompa) / Shaft (pump face)	ACCIAIO INOX / STAINLESS STEEL

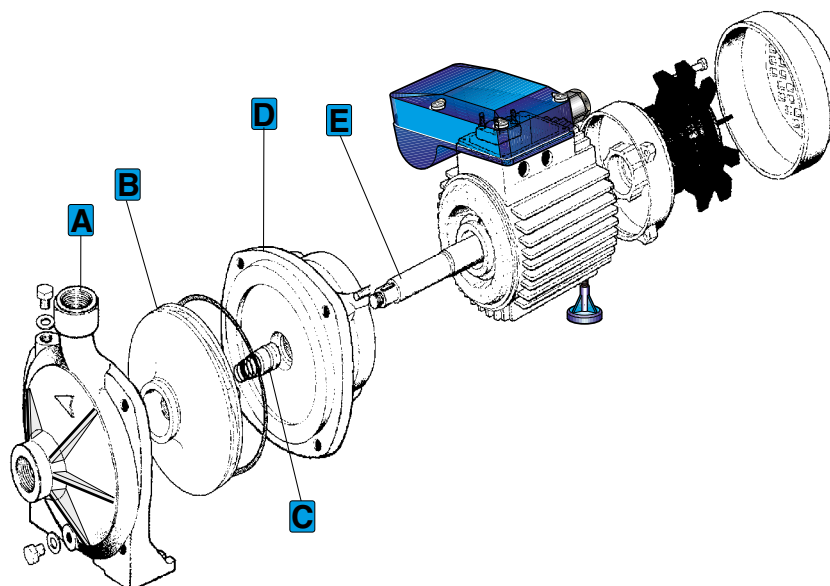

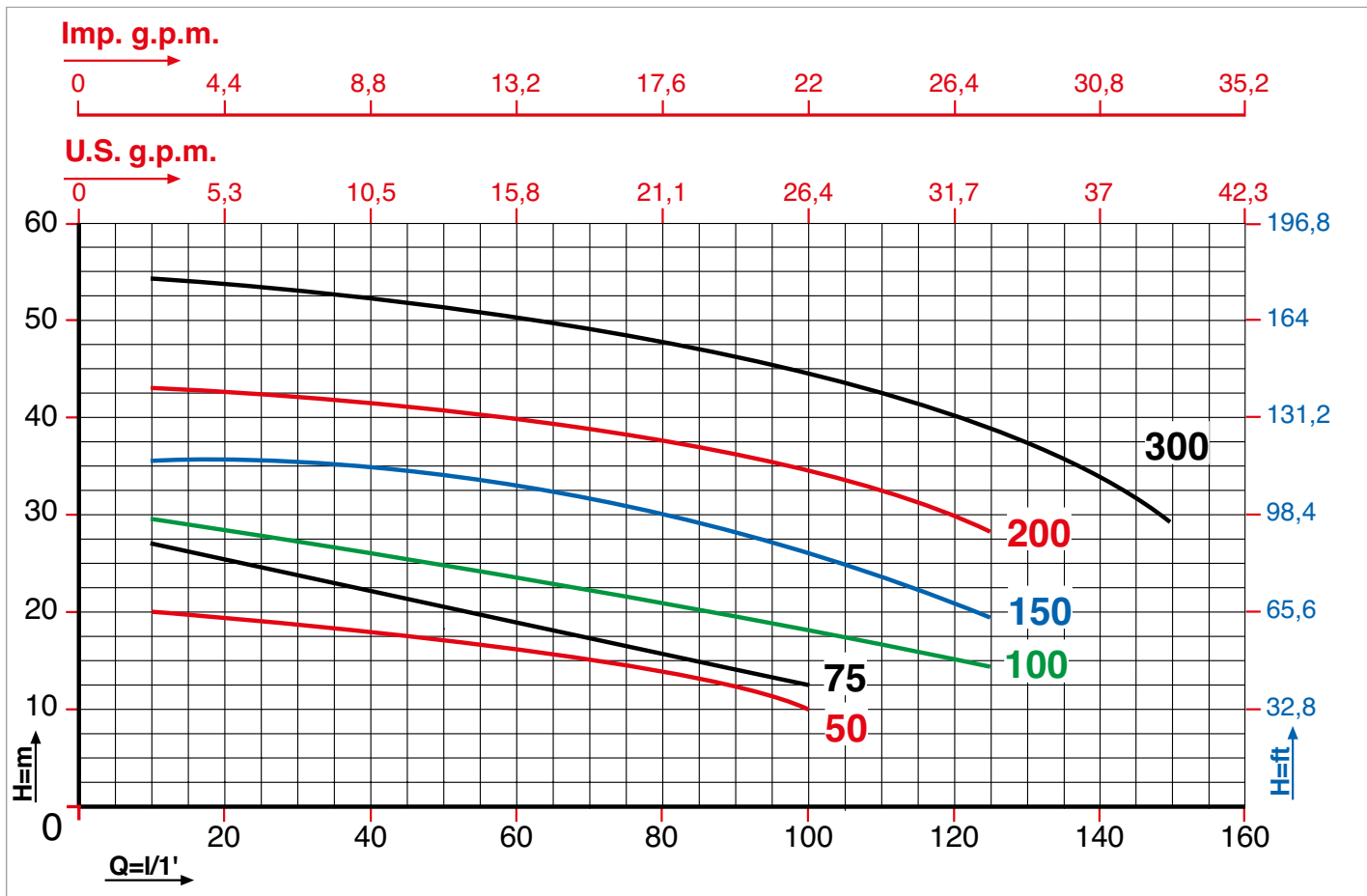

Caratteristiche di funzionamento a 2800 rpm 50Hz e 3450 rpm 60Hz - Performances at 2800 rpm 50 Hz and 3450 rpm 60 Hz
 Le prestazioni valgono per liquidi con densità $\rho = 1,0 \text{ kg/dm}^3$ ed una viscosità $\nu = 1 \text{ mm}^2/\text{s}$ / The performance data holds true for liquids with a $\rho = 1,0 \text{ kg/dm}^3$ density and a $\nu = 1 \text{ mm}^2/\text{s}$ viscosity.

MODELLO MODEL	VOLTAGGIO VOLTAGE	DATI ELETTRICI / ELECTRICAL DATA						DATI IDRAULICI / HYDRAULIC DATA									
		P1 max		P2 nom.		I max	Condensatore Capacitor	H (m)									
		kW	kW	HP	Ampere	μF		VC	m ³ /h	0,6	1,2	2,4	3,6	4,8	6	7,5	9
R 50 M	1 x 220-230V	0,65	0,37	0,5	2,8	12,5	450	l/min.	10	20	40	60	80	100	125	150	
R 50 T	3 x 380-440V	0,65	0,37	0,5	1,2	---	---		20,0	18,0	17,5	16,0	13,5	10,0	---	---	
R 75 M	1 x 220-230V	0,9	0,55	0,75	4,0	12,5	450		27,0	25,0	22,5	18,0	15,0	12,0	---	---	
R 75 T	3 x 380-440V	0,9	0,55	0,75	1,7	---	---		27,0	25,0	22,5	18,0	15,0	12,0	---	---	
R 100 M	1 x 220-230V	1,2	0,75	1,0	5,5	20,0	450		29,0	28,0	26,0	23,0	21,0	18,0	14,0	---	
R 100 T	3 x 380-440V	1,2	0,75	1,0	2,3	---	---		29,0	28,0	26,0	23,0	21,0	18,0	14,0	---	
R 150 M	1 x 220-230V	1,75	1,1	1,5	8,0	32,0	450		36,0	35,5	34,5	33,5	30,0	26,0	19,0	---	
R 150 T	3 x 380-440V	1,75	1,1	1,5	4,0	---	---		36,0	35,5	34,5	33,5	30,0	26,0	19,0	---	
R 200 M	1 x 220-230V	2,4	1,5	2,0	10,5	35,0	450		43,0	42,0	41,5	40,5	37,5	34,0	28,0	---	
R 200 T	3 x 380-440V	2,4	1,5	2,0	5,0	---	---		43,0	42,0	41,5	40,5	37,5	34,0	28,0	---	
R 300 M	1 x 220-230V	3,3	2,2	3,0	15,0	60,0	450		54,0	53,0	52,5	51,0	47,5	45,0	38,0	29,0	
R 300 T	3 x 380-440V	3,3	2,2	3,0	5,5	---	---		54,0	53,0	52,5	51,0	47,5	45,0	38,0	29,0	

DIMENSIONI e PESI / SIZE AND WEIGHT DATA:

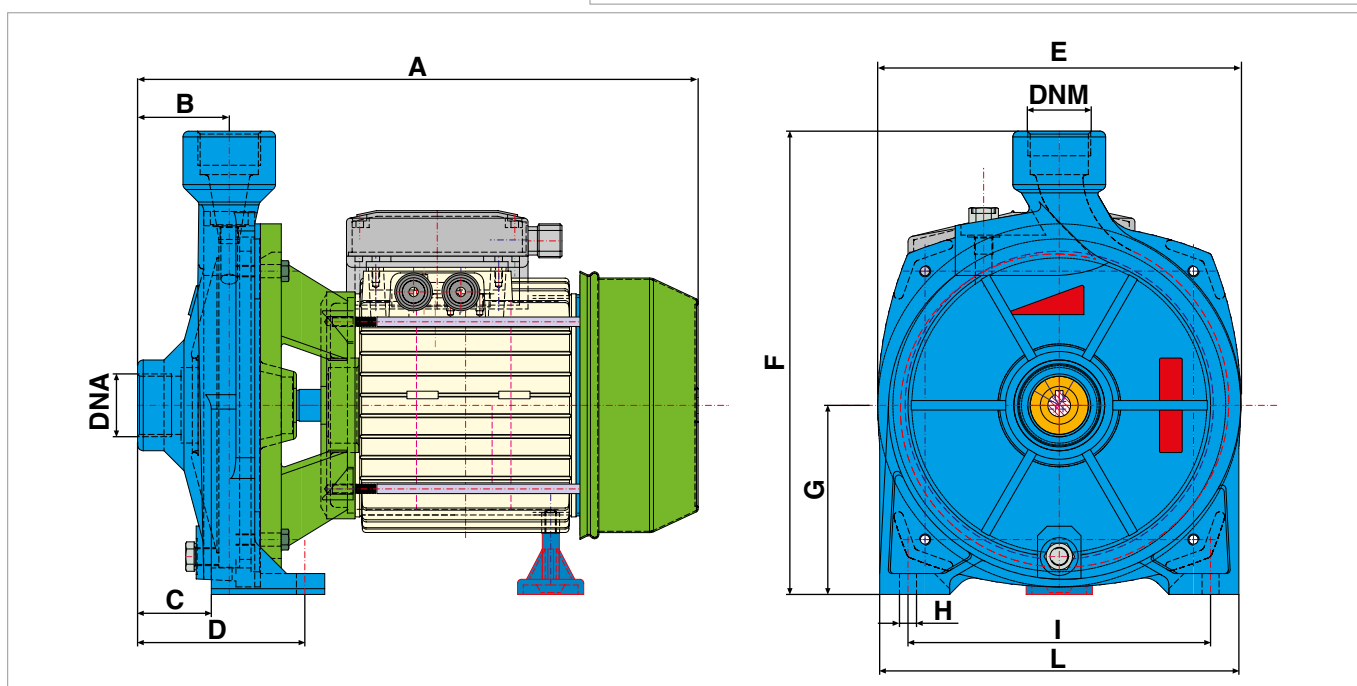
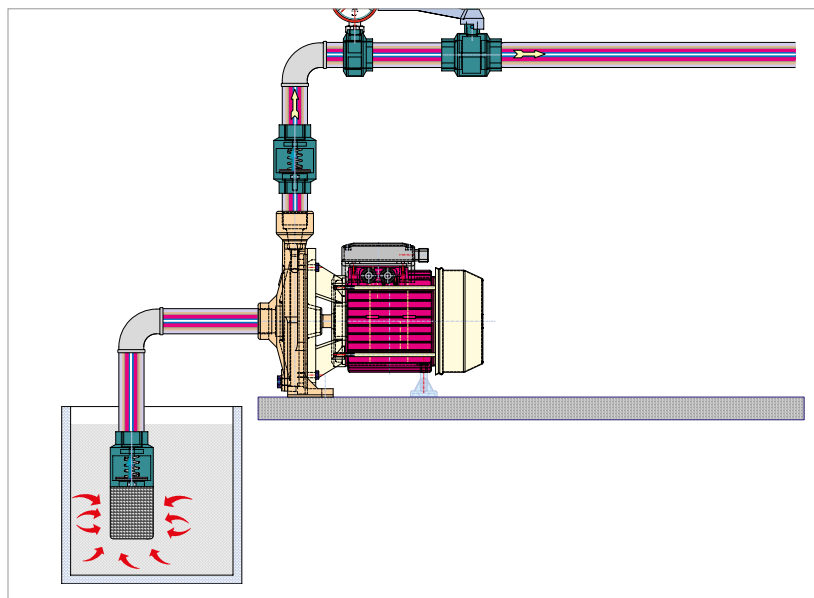
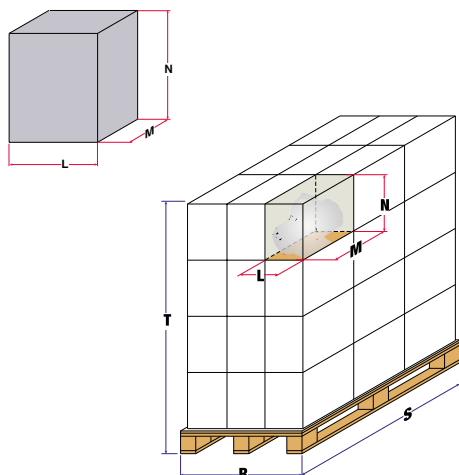

MODELLO / MODEL	DIMENSIONI POMPA in mm. / PUMP DIMENSIONS in mm.											
	DNA	DNM	A	B	C	D	E	F	G	H	I	L
R 50	1"	1"	260	47	90	100	164	205	83	9	126	162
R 75	1"	1"	300	50	98	108	186	229	94	9	140	176
R 100	1"	1"	300	50	98	108	186	229	94	9	140	176
R 150	1" 1/4	1"	355	48,5	45	76,5	224	305	125	12	147,5	220
R 200	1" 1/4	1"	410	48,5	45	76,5	224	305	125	12	147,5	220
R 300	1" 1/4	1"	410	48,5	45	76,5	224	305	125	12	147,5	220

MODELLO MODEL	DIMENSIONI SCATOLA / PACKING DIMENSIONS			
	L mm	M mm	N mm	Peso / Weight Kg
R 50	300	180	250	8,0
R 75	340	195	250	9,2
R 100	340	195	250	11,8
R 150	380	240	360	23,0
R 200	440	240	360	24,0
R 300	440	240	360	27,0

RB



ELETTROPOMPE CENTRIFUGHE CON DUE GIRANTI CENTRIFUGAL ELECTRIC PUMPS WITH TWO IMPELLERS

PREVALENZA : 44 mt. ÷ 90 mt.
PORTATA : 3 m³/h ÷ 16,5 m³/h
POTENZA NOMINALE : 0,75 kW (1HP) ÷ 5,5 kW (7,5HP)

PUMP HEAD : 44,0 mt ÷ 90,0 mt
DELIVERY : 3,0m³/h ÷ 16,5 m³/h
RATED HORSEPOWER : 0,75 kW (1,0HP) ÷ 5,5 kW (7,5HP)

APPLICAZIONI

- PRESSURIZZAZIONE DI IMPIANTI DOMESTICI E PICCOLA IRRIGAZIONE.
- MOVIMENTAZIONE DI LIQUIDI NON AGGRESSIVI PER USI CIVILI ED INDUSTRIALI.
- IMPIANTI DI LAVAGGIO, INSERIMENTO SU MACCHINARI PIU' COMPLESSI PER USI INDUSTRIALI.

APPLICATIONS

- FOR DOMESTIC SYSTEMS AND SMALL IRRIGATION SYSTEM PRESSURISATION.
- HANDLING OF NON AGGRESSIVE CIVIL AND INDUSTRIAL LIQUIDS.
- FOR WASHING SYSTEMS AND FOR INSERTION INTO COMPLEX INDUSTRIAL MACHINERY AND LINES.



ARVEN[®]
WATER PUMPS

CARATTERISTICHE DI COSTRUZIONE:

- MOTORE CHIUSO CON VENTILAZIONE ESTERNA E CASSA ALETTATA IN LEGA DI ALLUMINIO.
- GRADO DI PROTEZIONE IP 44.
- CLASSE DI ISOLAMENTO: F.
- TEMPERATURA MAX.LIQUIDO POMPATO: 35°C.
- VERSIONI: Monofase: 220 - 230V/50Hz o 220 - 230V/60Hz con protettore termico incorporato e condensatore permanentemente inserito.
Trifase: 220 - 230V/50Hz e 380 - 400V/50Hz o 220 - 230V/60Hz e 380 - 400V/60Hz con protezione da sovraccarico a cura dell'utente.
- POTENZA MOTORE: 1 Hp solo VERSIONE MONOFASE.
DA 1,5 Hp a 2 Hp VERSIONE MONOFASE E TRIFASE
DA 3 Hp a 7,5 SOLO VERSIONE TRIFASE.

SPECIALI VOLTAGGI E FREQUENZE A RICHIESTA.

DESIGN ENGINEERING:

- SEALED MOTOR WITH EXTERNAL VENTILATION AND FINNED ALUMINIUM ALLOY CASING.
- IP 44 PROTECTION CLASS.
- CLASS "F" INSULATION.
- MAX. PUMPED LIQUID TEMPERATURE: 35°C.
- VERSIONS: Single Phase: 220 - 230 V/50 Hz with built in thermal protection and permanent capacitor.
Three Phase: 220 - 230V/50Hz or 380- 400V/50Hz and 220 - 230V/60Hz or 380 - 400V/60Hz with overload protection care of the User.
- MOTOR POWER: 1 Hp only single phase versions.
From 1.5 Hp to 2 Hp single phase and three phases versions
From 3 Hp to 7,5 only Three Phases versions.

CUSTOMISED VOLTAGE AND FREQUENCY RATING AVAILABLE ON DEMAND.

TABELLA MATERIALI / MATERIALS TABLE:

Pos.	Componente / Component	Materiale / Materials
A	Corpo pompa / Pump body	GHISA / CAST IRON
B	Girante / Impeller	OTTONE / BRASS
C	Tenuta meccanica / Mechanical Seal	CERAMICA-GRAFITE / CERAMIC-GRAPHITE
D	Flangia / Flange	GHISA / CAST IRON
E	Albero (lato pompa) / Shaft (pump face)	ACCIAIO INOX / STAINLESS STEEL

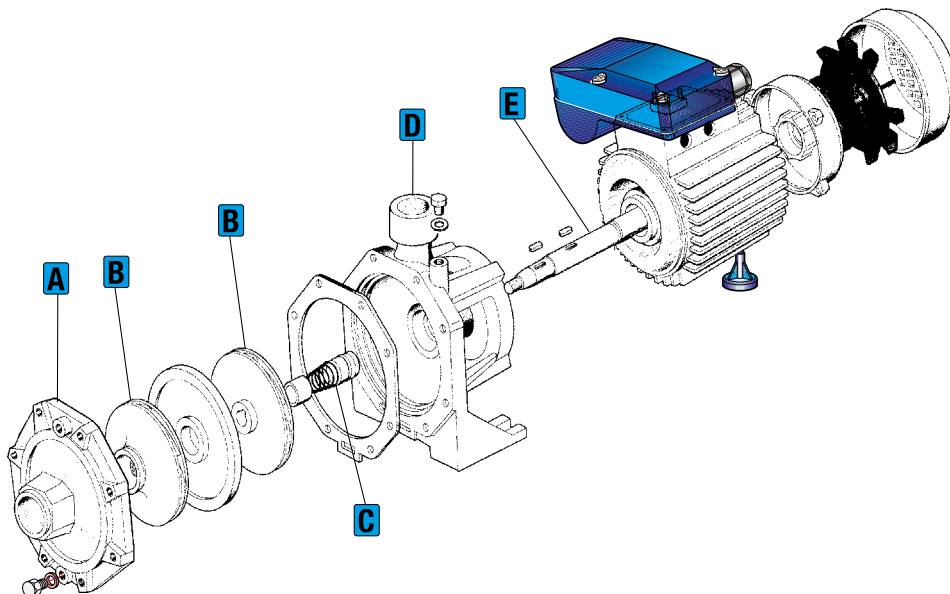

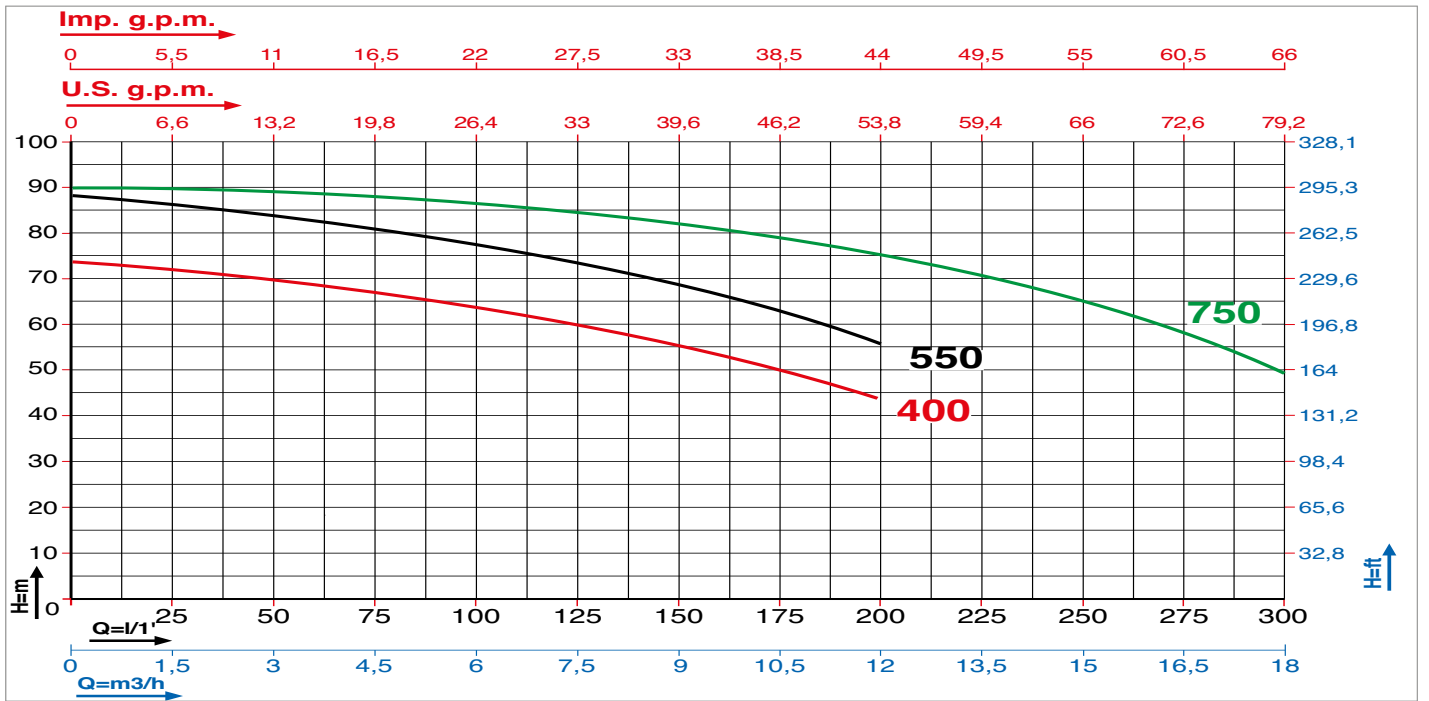
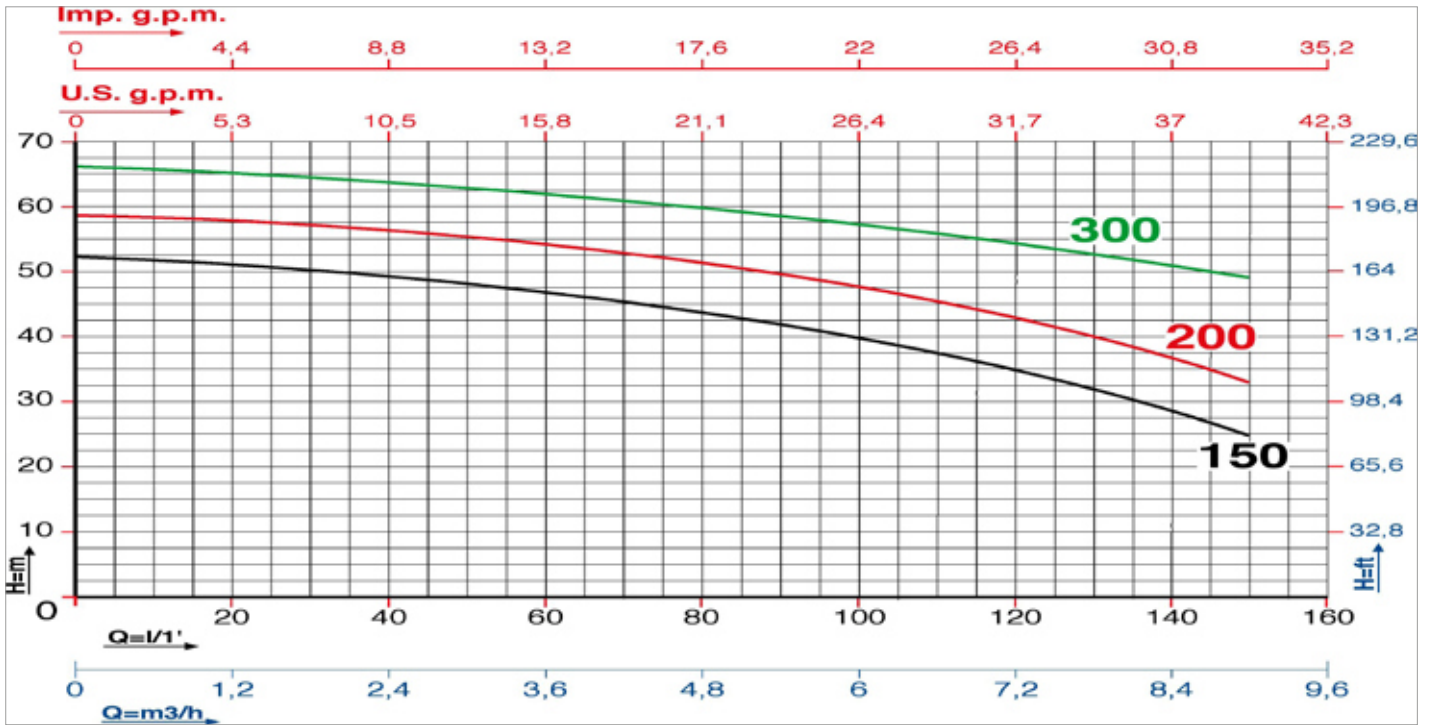

Caratteristiche di funzionamento a 2800 rpm 50Hz e 3450 rpm 60Hz - Performances at 2800 rpm 50 Hz and 3450 rpm 60 Hz
 Le prestazioni valgono per liquidi con densità $\rho = 1,0 \text{ kg/dm}^3$ ed una viscosità $\nu = 1 \text{ mm}^2/\text{s}$ / The performance data holds true for liquids with a $\rho = 1,0 \text{ kg/dm}^3$ density and a $\nu = 1 \text{ mm}^2/\text{s}$ viscosity.

MODELLO MODEL	VOLTAGGIO VOLTAGE	DATI ELETTRICI / ELECTRICAL DATA						DATI IDRAULICI / HYDRAULIC DATA								PREVALENZA TOTALE IN METRI COLONNA ACQUA TOTAL PUMP HEAD AND WATER COLUMN HEIGHT IN m.		
		P1 max kW	P2 nom. kW	I max HP	I max Ampere	Condensatore Capacitor		H (m)										
						μF	VC	0	1,5	3	6	9	12	15	18			
RB 150 M	1 x 220-230V	2,2	1,1	1,5	10,0	35,0	450	52,0	50,5	48,5	40,0	25,0	---	---	---	---	---	---
RB 150 T	3 x 380-440V	2,2	1,1	1,5	4,3	---	---	52,0	50,5	48,5	40,0	25,0	---	---	---	---	---	---
RB 200 M	1 x 220-230V	2,6	1,5	2,0	12,0	35,0	450	58,0	57,5	55,5	47,5	33,0	---	---	---	---	---	---
RB 200 T	3 x 380-440V	2,6	1,5	2,0	5,0	---	---	58,0	57,5	55,5	47,5	33,0	---	---	---	---	---	---
RB 300 T	3 x 380-440V	3,6	2,2	3,0	7,0	---	---	66,0	64,5	63,0	57,0	49,0	---	---	---	---	---	---
RB 400 T	3 x 380-440V	4,5	3,0	4,0	7,5	---	---	73,5	72,0	69,5	63,0	55,0	43,0	---	---	---	---	---
RB 550 T	3 x 380-440V	6,0	4,0	5,5	9,3	---	---	88,0	86,0	84,0	77,0	68,0	56,0	---	---	---	---	---
RB 750 T	3 x 380-440V	8,0	5,5	7,5	13,0	---	---	90,0	89,5	89,0	87,0	82,5	76,0	64,0	49,0	---	---	---

DIMENSIONI e PESI / SIZE AND WEIGHT DATA:

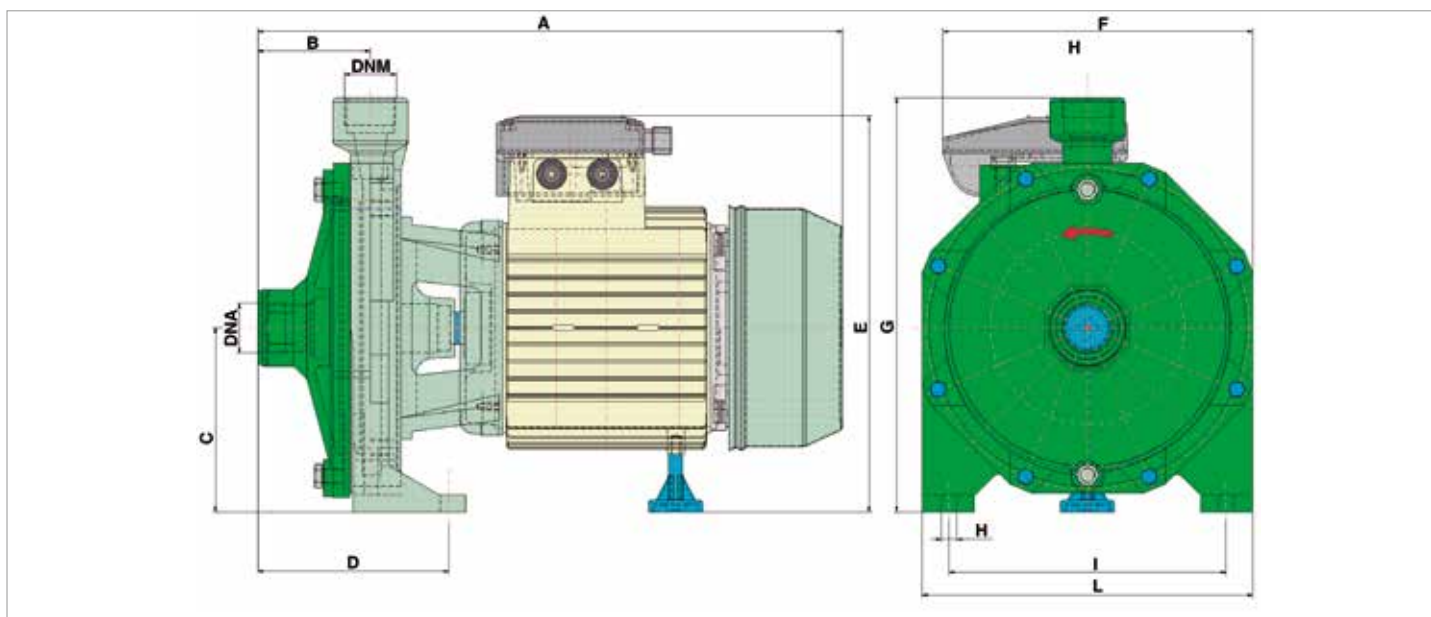
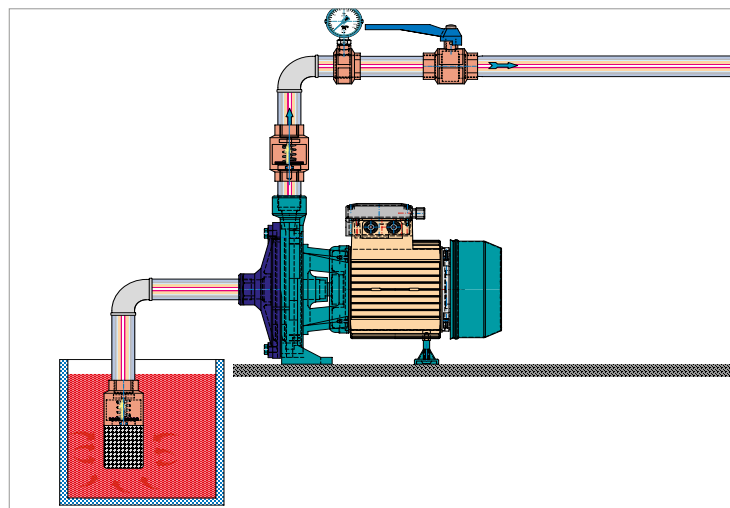
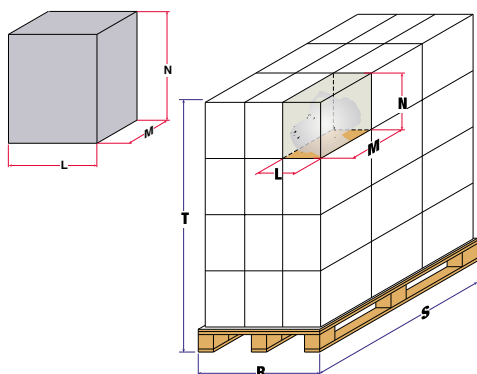

MODELLO / MODEL	DIMENSIONI POMPA in mm. / PUMP DIMENSIONS in mm.											
	DNA	DNM	A	B	C	D	E	F	G	H	I	L
RB 150	1" 1/4	1"	400	85	120	95	255	222	265	10	168	208
RB 200	1" 1/4	1"	432	85	120	95	255	222	265	10	168	208
RB 300	1" 1/4	1"	440	92,5	132	108,5	280	246	290	12	190	230
RB 400	1" 1/2	1" 1/4	485	94	160	120	330	272	340	15	200	250
RB 550	1" 1/2	1" 1/4	495	94	160	120	330	272	340	15	200	250
RB 750	2"	1" 1/4	575	107	160	121	365	300	375	15	225	280

MODELLO MODEL	DIMENSIONI SCATOLA / PACKING DIMENSIONS			
	L mm	M mm	N mm	Peso / Weight Kg
RB 100	357	197	270	16,0
RB 150	412	230	310	23,5
RB 200	412	230	310	26,0
RB 300	530	300	460	27,0
RB 400	530	300	460	46,0
RB 550	530	300	460	53,0
RB 750	610	330	480	71,0

RPG



ELETTROPOMPE CENTRIFUGHE MULTICELLULARI IN GHISA **CENTRIFUGAL MULTISTAGE ELECTRIC CAST IRON PUMPS**

PREVALENZA : 44 mt. ÷ 90 mt.
PORTATA : 3 m³/h ÷ 16,5 m³/h
POTENZA NOMINALE : 0,55 kW (0,75HP) ÷ 0,75 kW (1,0HP)

PUMP HEAD : 44,0 mt ÷ 90,0 mt
DELIVERY : 3,0m³/h ÷ 16,5 m³/h
RATED HORSEPOWER : 0,55 kW (0,75HP) ÷ 0,75 kW (1,0HP)

APPLICAZIONI

- PRESSURIZZAZIONE DI IMPIANTI DOMESTICI E PICCOLA IRRIGAZIONE.
- MOVIMENTAZIONE DI LIQUIDI NON AGGRESSIVI PER USI CIVILI ED INDUSTRIALI.
- IMPIANTI DI LAVAGGIO, INSERIMENTO SU MACCHINARI PIU' COMPLESSI PER USI INDUSTRIALI.

APPLICATIONS

- FOR DOMESTIC SYSTEMS AND SMALL IRRIGATION SYSTEM PRESSURISATION.
- HANDLING OF NON AGGRESSIVE CIVIL AND INDUSTRIAL LIQUIDS.
- FOR WASHING SYSTEMS AND FOR INSERTION INTO COMPLEX INDUSTRIAL MACHINERY AND LINES.



CARATTERISTICHE DI COSTRUZIONE:

- MOTORE CHIUSO CON VENTILAZIONE ESTERNA E CASSA ALETTATA IN LEGA DI ALLUMINIO.
- GRADO DI PROTEZIONE IP 44.
- CLASSE DI ISOLAMENTO: F.
- TEMPERATURA MAX. LIQUIDO POMPATO: 35°C.
- VERSIONI: Monofase: 220 - 230V/50Hz o 220 - 230V/60Hz con protettore termico incorporato e condensatore permanentemente inserito.
Trifase: 220 - 230V/50Hz e 380 - 400V/50Hz o 220 - 230V/60Hz e 380 - 400V/60Hz con protezione da sovraccarico a cura dell'utente.
- POTENZA MOTORE: 1 Hp solo VERSIONE MONOFASE.
DA 1,5 Hp a 2 Hp VERSIONE MONOFASE E TRIFASE
DA 3 Hp a 7,5 SOLO VERSIONE TRIFASE.

SPECIALI VOLTAGGI E FREQUENZE A RICHIESTA.

DESIGN ENGINEERING:

- SEALED MOTOR WITH EXTERNAL VENTILATION AND FINNED ALUMINIUM ALLOY CASING.
- IP 44 PROTECTION CLASS.
- CLASS "F" INSULATION.
- MAX. PUMPED LIQUID TEMPERATURE: 35°C.
- VERSIONS: Single Phase: 220 - 230 V/50 Hz with built in thermal protection and permanent capacitor.
Three Phase: 220 - 230V/50Hz or 380- 400V/50Hz and 220 - 230V/60Hz or 380 - 400V/60Hz with overload protection care of the User.
- MOTOR POWER: 1 Hp only single phase versions.
From 1.5 Hp to 2 Hp single phase and three phases versions
From 3 Hp to 7,5 only Three Phases versions.

CUSTOMISED VOLTAGE AND FREQUENCY RATING AVAILABLE ON DEMAND.

TABELLA MATERIALI / MATERIALS TABLE:

Pos.	Componente / Component	Materiale / Materials
A	Corpo pompa / Pump body	GHISA / CAST IRON
B	Girante / Impeller	NORYL
C	Tenuta meccanica / Mechanical Seal	CERAMICA-GRAFITE / CERAMIC-GRAPHITE
D	Flangia / Flange	GHISA / CAST IRON
E	Albero (lato pompa) / Shaft (pump face)	ACCIAIO INOX / STAINLESS STEEL

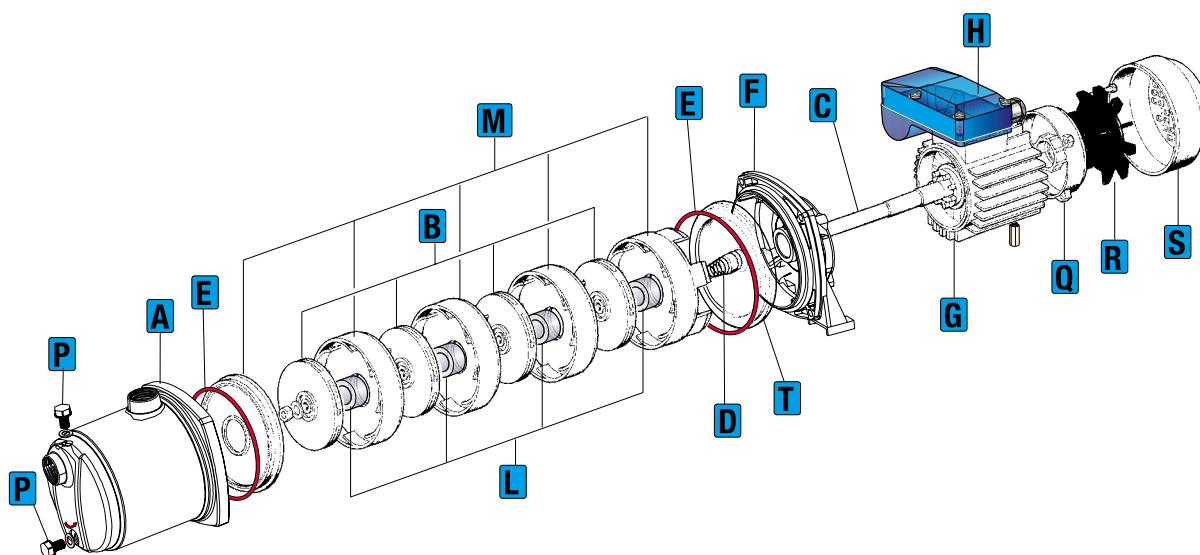

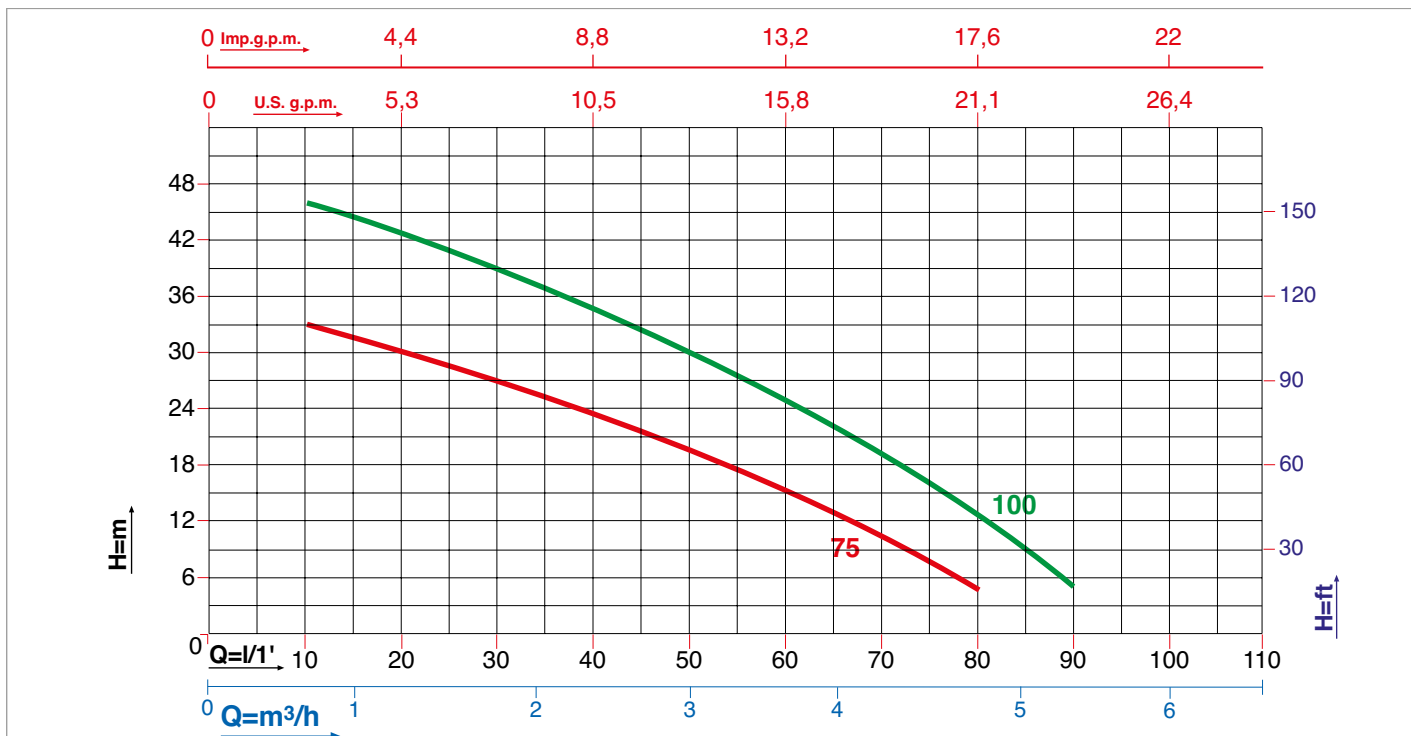

Caratteristiche di funzionamento a 2800 rpm 50Hz e 3450 rpm 60Hz - Performances at 2800 rpm 50 Hz and 3450 rpm 60 Hz
 Le prestazioni valgono per liquidi con densità $p = 1,0 \text{ kg/dm}^3$ ed una viscosità $v = 1 \text{ mm}^2/\text{s}$ / The performance data holds true for liquids with a $p = 1,0 \text{ kg/dm}^3$ density and a $v = 1 \text{ mm}^2/\text{s}$ viscosity.

MODELLO MODEL	VOLTAGGIO VOLTAGE	DATI ELETTRICI / ELECTRICAL DATA						DATI IDRAULICI / HYDRAULIC DATA									
		P1 max		P2 nom.		I max	Condensatore Capacitor	m³/h	0,6	1,2	1,8	2,4	3	3,6	4,2	4,8	5,4
		kW	HP	Ampere	µF	VC		l/min.	10	20	30	40	50	60	70	80	90
RPG 75 M	1 x 220-230V	0,75	0,55	0,75	3,3	450	H (m)	33,0	30,0	26,0	23,5	18,5	14,0	10,0	5,0	---	
RPG 100 M	1 x 220-230V	1,0	0,75	1,0	4,3	450		46,0	43,0	39,0	35,0	30,0	24,0	16,5	10,0	5,0	

PREVALENZA TOTALE IN METRI COLONNA ACQUA
TOTAL PUMP HEAD AND WATER COLUMN HEIGHT IN m.

DIMENSIONI e PESI / SIZE AND WEIGHT DATA:

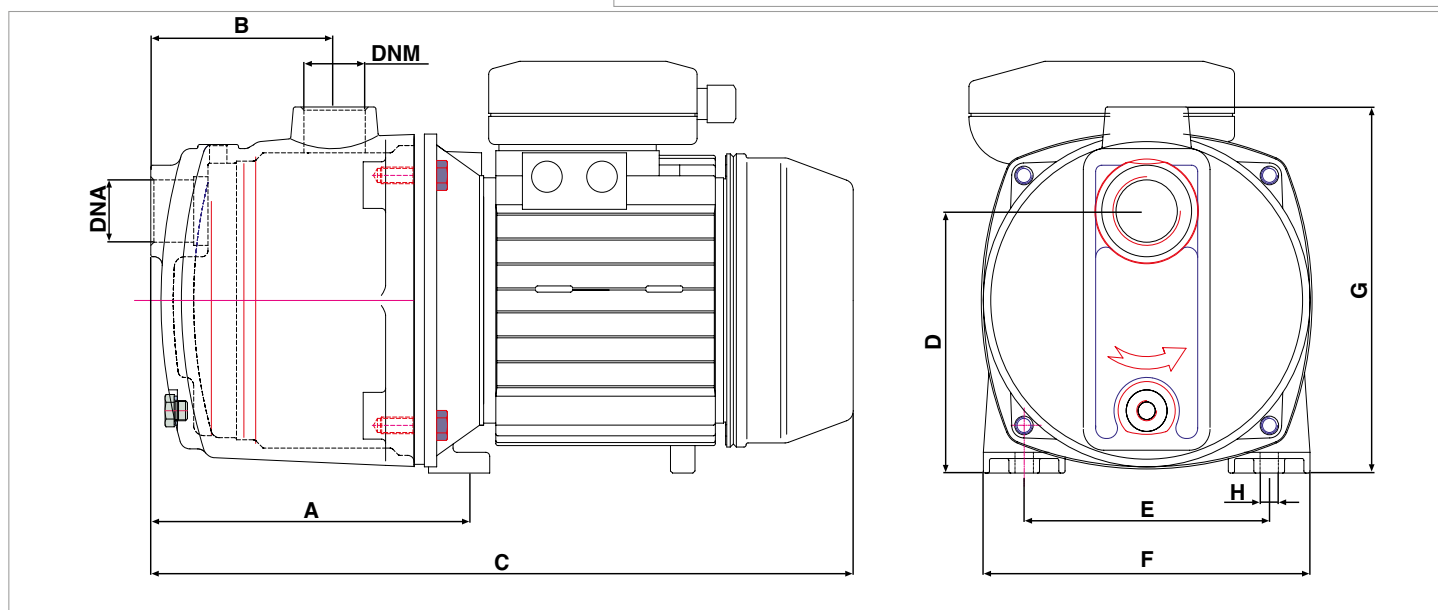
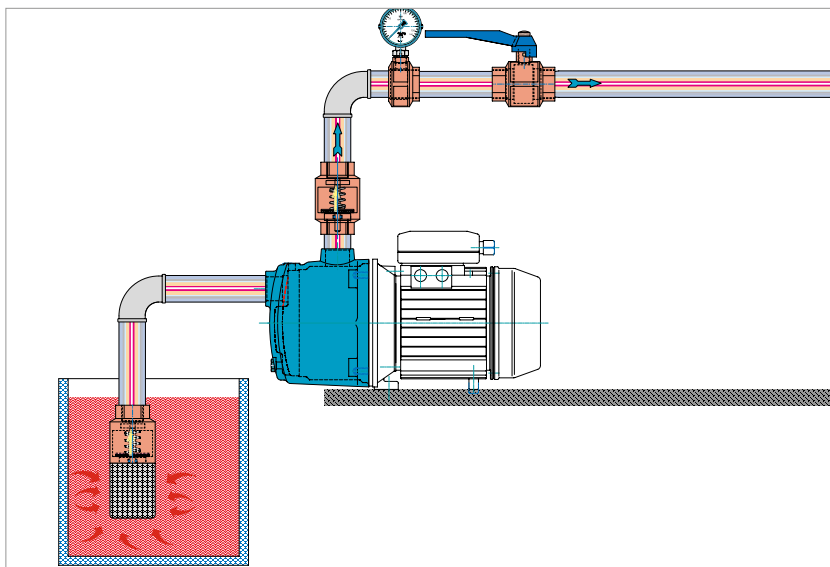
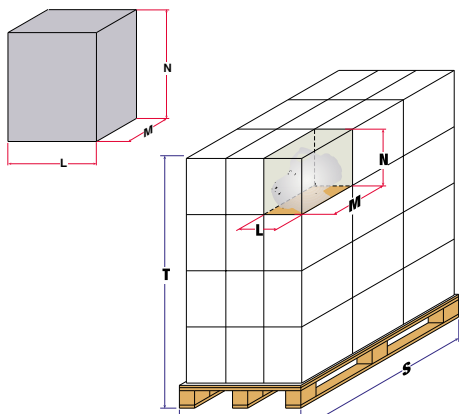

MODELLO / MODEL	DIMENSIONI POMPA in mm. / PUMP DIMENSIONS in mm.									
	DNA	DNM	A	B	C	D	E	F	G	H
RPG 75 M	1"	1"	96	103	325	135	120	154	178	9
RPG 100 M	1"	1"	119	128	376	135	120	154	193	9

MODELLO MODEL	DIMENSIONI SCATOLA / PACKING DIMENSIONS			
	L mm	M mm	N mm	Peso / Weight Kg
RPG 75 M	345	175	220	10,5
RPG 100 M	400	175	240	13,5

RPX



ELETTROPOMPE CENTRIFUGHE MULTICELLULARI IN ACCIAIO INOX CENTRIFUGAL MULTISTAGE ELECTRIC STAINLESS STEEL PUMPS

PREVALENZA : 34 mt. ÷ 58 mt.
PORTATA : 4,8 m³/h ÷ 5,4 m³/h
POTENZA NOMINALE : 0,7 kW (0,9HP) ÷ 1,0 kW (1,3HP)

PUMP HEAD : 34,0 mt ÷ 58,0 mt
DELIVERY : 4,2 m³/h ÷ 5,4 m³/h
RATED HORSEPOWER : 0,7 kW (0,9HP) ÷ 1,0 kW (1,3HP)

APPLICAZIONI

- PRESSURIZZAZIONE DI IMPIANTI DOMESTICI E PICCOLA IRRIGAZIONE.
- MOVIMENTAZIONE DI LIQUIDI NON AGGRESSIVI PER USI CIVILI ED INDUSTRIALI.
- IMPIANTI DI LAVAGGIO, INSERIMENTO SU MACCHINARI PIU' COMPLESSI PER USI INDUSTRIALI.

APPLICATIONS

- FOR DOMESTIC SYSTEMS AND SMALL IRRIGATION SYSTEM PRESSURISATION.
- HANDLING OF NON AGGRESSIVE CIVIL AND INDUSTRIAL LIQUIDS.
- FOR WASHING SYSTEMS AND FOR INSERTION INTO COMPLEX INDUSTRIAL MACHINERY AND LINES.

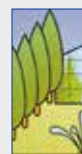

CARATTERISTICHE DI COSTRUZIONE:

- MOTORE CHIUSO CON VENTILAZIONE ESTERNA E CASSA ALETTATA IN LEGA DI ALLUMINIO.
- GRADO DI PROTEZIONE IP 44.
- CLASSE DI ISOLAMENTO: F.
- TEMPERATURA MAX.LIQUIDO POMPATO: 35°C.
- VERSIONI: Monofase: 220 - 230V/50Hz o 220 - 230V/60Hz con protettore termico incorporato e condensatore permanentemente inserito.
- POTENZA MOTORE: DA 0,9 Hp ÷ 1,3 Hp solo VERSIONE MONOFASE.

SPECIALI VOLTAGGI E FREQUENZE A RICHIESTA.

DESIGN ENGINEERING:

- SEALED MOTOR WITH EXTERNAL VENTILATION AND FINNED ALUMINIUM ALLOY CASING.
- IP 44 PROTECTION CLASS.
- CLASS "F" INSULATION.
- MAX. PUMPED LIQUID TEMPERATURE: 35°C.
- VERSIONS: Single Phase: 220 - 230 V/50 ou 220 - 230V/60Hz Hz with built in thermal protection and permanent capacitor.
- MOTOR POWER: From 0.9 Hp to 1.3 Hp only single phase versions.

CUSTOMISED VOLTAGE AND FREQUENCY RATING AVAILABLE ON DEMAND.

TABELLA MATERIALI / MATERIALS TABLE:

Pos.	Componente / Component	Materiale / Materials
A	Corpo pompa / Pump body	ACCIAIO INOX / STAINLESS STEEL
B	Diffusore / Diffuser	NORYL
C	Girante / Impeller	NORYL
D	Tenuta meccanica / Mechanical Seal	CERAMICA-GRAFITE / CERAMIC-GRAPHITE
E	Flangia / Flange	GHISA / CAST IRON
F	Albero (lato pompa) / Shaft (pump face)	ACCIAIO INOX / STAINLESS STEEL

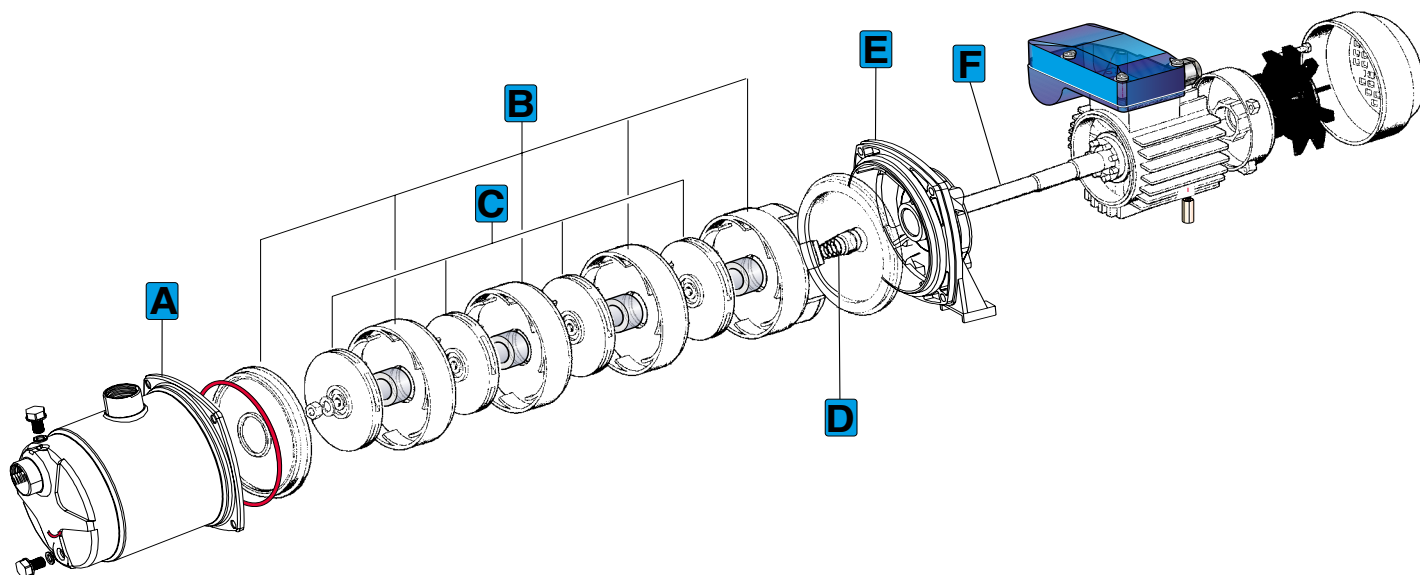

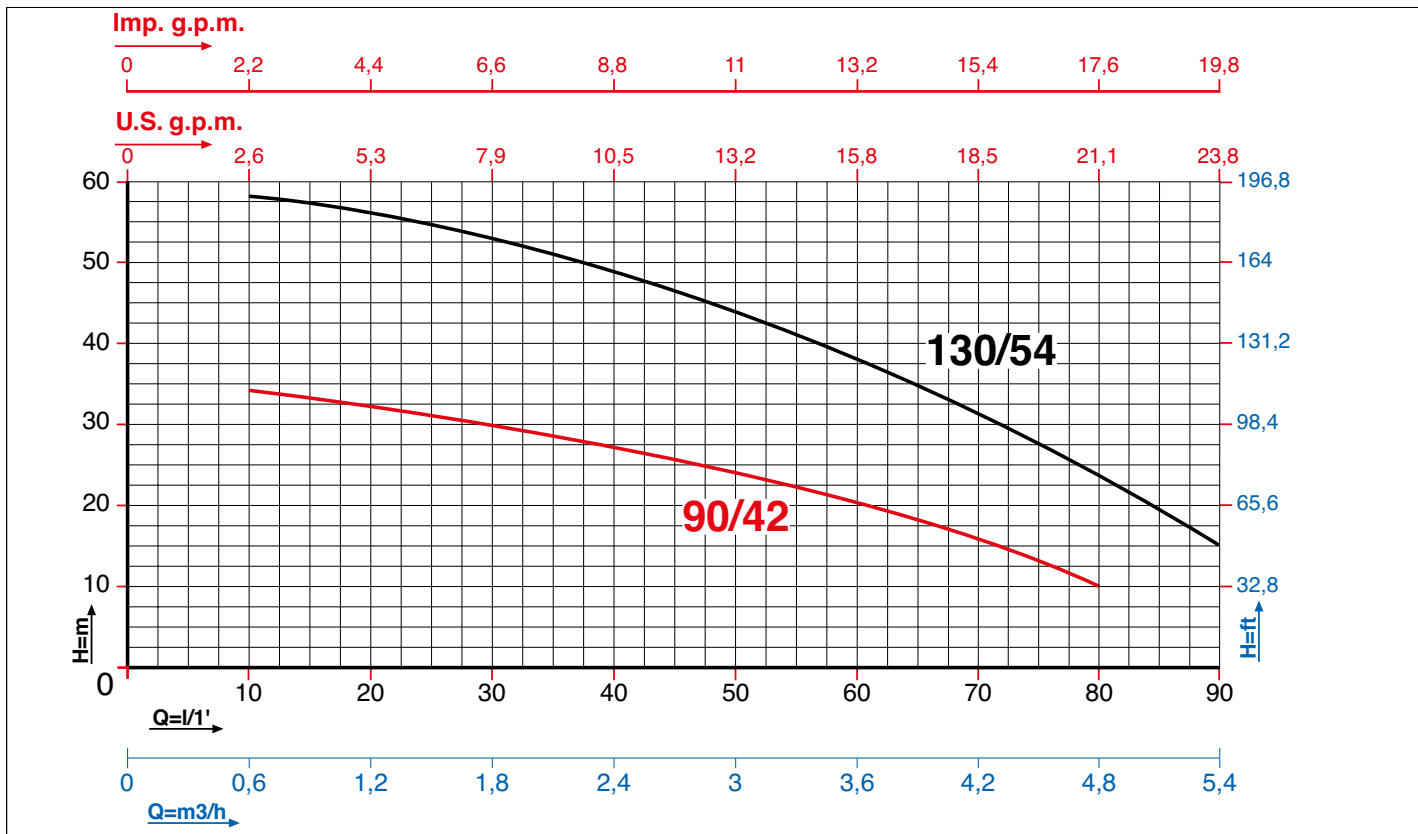

Caratteristiche di funzionamento a 2800 rpm 50Hz e 3450 rpm 60Hz - Performances at 2800 rpm 50 Hz and 3450 rpm 60 Hz
 Le prestazioni valgono per liquidi con densità $\rho = 1,0 \text{ kg/dm}^3$ ed una viscosità $\nu = 1 \text{ mm}^2/\text{s}$ / The performance data holds true for liquids with a $\rho = 1,0 \text{ kg/dm}^3$ density and a $\nu = 1 \text{ mm}^2/\text{s}$ viscosity.

MODELLO MODEL	VOLTAGGIO VOLTAGE	DATI ELETTRICI / ELECTRICAL DATA						DATI IDRAULICI / HYDRAULIC DATA										
		P1 max		P2 nom.		I max	Condensatore Capacitor		m³/h	0,6	1,2	1,8	2,4	3	3,6	4,2	4,8	5,4
		kW	kW	HP	Ampere	µF	VC	l/min.	10	20	30	40	50	60	70	80	90	
RPX 90/42 M	1 x 220-230V	0,9	0,7	0,9	4,0	12,5	450	H (m)	34,0	32,0	30,0	28,0	24,0	20,0	15,0	10,0	---	
RPX 130/54 M	1 x 220-230V	1,3	1,0	1,3	5,8	20,0	450	H (m)	58,0	56,0	52,0	48,0	44,0	39,0	31,0	23,0	---	

PREVALENZA TOTALE in METRI COLONNA ACQUA / TOTAL PUMP HEAD AND WATER COLUMN HEIGHT IN m.

DIMENSIONI e PESI / SIZE AND WEIGHT DATA:

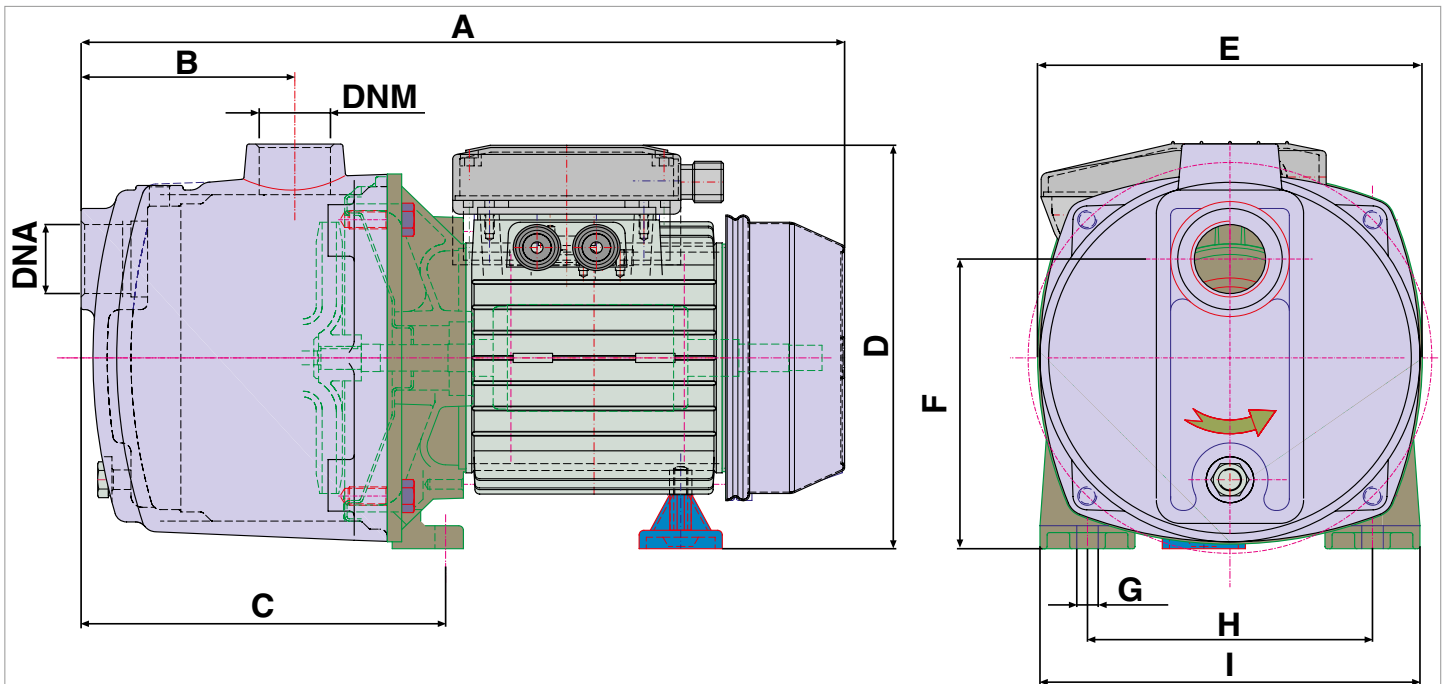
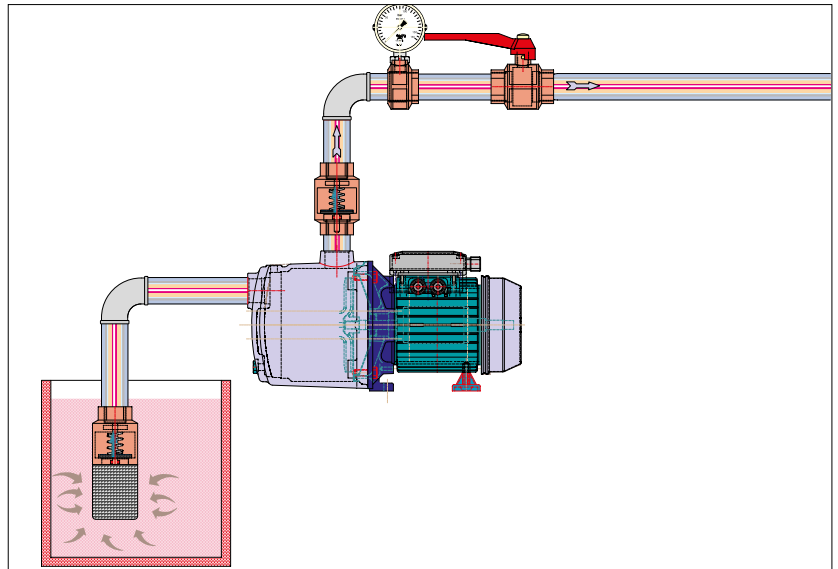
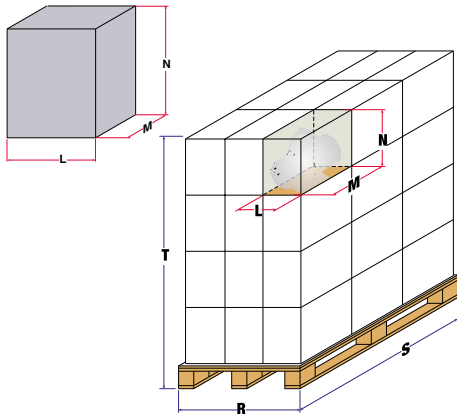

MODELLO / MODEL	DIMENSIONI POMPA in mm. / PUMP DIMENSIONS in mm.										
	DNA	DNM	A	B	C	D	E	F	G	H	I
RPX 90/42	1"	1"	343	81	163	200	184	149	9	140	176
RPX 130/54	1"	1"	415	113	210	212	206	154	9	140	176

MODELLO MODEL	DIMENSIONI SCATOLA / PACKING DIMENSIONS			
	L mm	M mm	N mm	Peso / Weight Kg
RPX 90/42	420	190	230	8,5
RPX 130/54	450	210	240	13,0

RM



ELETTROPOMPE CENTRIFUGHE MULTICELLULARI IN ACCIAIO INOX CENTRIFUGAL MULTISTAGE ELECTRIC STAINLESS STEEL PUMPS

PREVALENZA : 34 mt. ÷ 60 mt.
PORTATA : 5,4 m³/h
POTENZA NOMINALE : 0,6 kW (0,8HP) ÷ 1,1 kW (1,5HP)

PUMP HEAD : 34,0 mt ÷ 60,0 mt
DELIVERY : 5,4 m³/h
RATED HORSEPOWER : 0,6 kW (0,8HP) ÷ 1,1 kW (1,5HP)

APPLICAZIONI

- PRESSURIZZAZIONE DI IMPIANTI DOMESTICI E PICCOLA IRRIGAZIONE.
- MOVIMENTAZIONE DI LIQUIDI NON AGGRESSIVI PER USI CIVILI ED INDUSTRIALI.
- IMPIANTI DI LAVAGGIO, INSERIMENTO SU MACCHINARI PIU' COMPLESSI PER USI INDUSTRIALI.

APPLICATIONS

- FOR DOMESTIC SYSTEMS AND SMALL IRRIGATION SYSTEM PRESSURISATION.
- HANDLING OF NON AGGRESSIVE CIVIL AND INDUSTRIAL LIQUIDS.
- FOR WASHING SYSTEMS AND FOR INSERTION INTO COMPLEX INDUSTRIAL MACHINERY AND LINES.



ARVEN[®]
WATER PUMPS

CARATTERISTICHE DI COSTRUZIONE:

- MOTORE CHIUSO CON VENTILAZIONE ESTERNA E CASSA ALETTATA IN LEGA DI ALLUMINIO.
- GRADO DI PROTEZIONE IP 44.
- CLASSE DI ISOLAMENTO: F.
- TEMPERATURA MAX.LIQUIDO POMPATO: 35°C.
- VERSIONI: Monofase: 220 - 230V/50Hz o 220 - 230V/60Hz con protettore termico incorporato e condensatore permanentemente inserito.
Trifase: 220 - 230V/50Hz e 380 - 400V/50Hz o 220 - 230V/60Hz e 380 - 400V/60Hz con protezione da sovraccarico a cura dell'utente.
- POTENZA MOTORE: 0,8 Hp solo VERSIONE MONOFASE.
DA 1,0 Hp a 1,5 Hp VERSIONE MONOFASE E TRIFASE

SPECIALI VOLTAGGI E FREQUENZE A RICHIESTA.

DESIGN ENGINEERING:

- SEALED MOTOR WITH EXTERNAL VENTILATION AND FINNED ALUMINIUM ALLOY CASING.
- IP 44 PROTECTION CLASS.
- CLASS "F" INSULATION.
- MAX. PUMPED LIQUID TEMPERATURE: 35°C.
- VERSIONS: Single Phase: 220 - 230 V/50 Hz with built in thermal protection and permanent capacitor.
Three Phase: 220 - 230V/50Hz or 380- 400V/50Hz and 220 - 230V/60Hz or 380 - 400V/60Hz with overload protection care of the User.
- MOTOR POWER: 0.8 Hp only single phase versions.
From 1.0 Hp to 1.5 Hp single phase and three phases versions

CUSTOMISED VOLTAGE AND FREQUENCY RATING AVAILABLE ON DEMAND.

TABELLA MATERIALI / MATERIALS TABLE:

Pos.	Componente / Component	Materiale / Materials
A	Corpo pompa / Pump body	GHISA / CAST IRON
B	Diffusore / Diffuser	NORYL
C	Girante / Impeller	NORYL
D	Tenuta meccanica / Mechanical Seal	CERAMICA-GRAFITE / CERAMIC-GRAPHITE
E	Flangia / Flange	GHISA / CAST IRON
F	Albero (lato pompa) / Shaft (pump face)	ACCIAIO INOX / STAINLESS STEEL

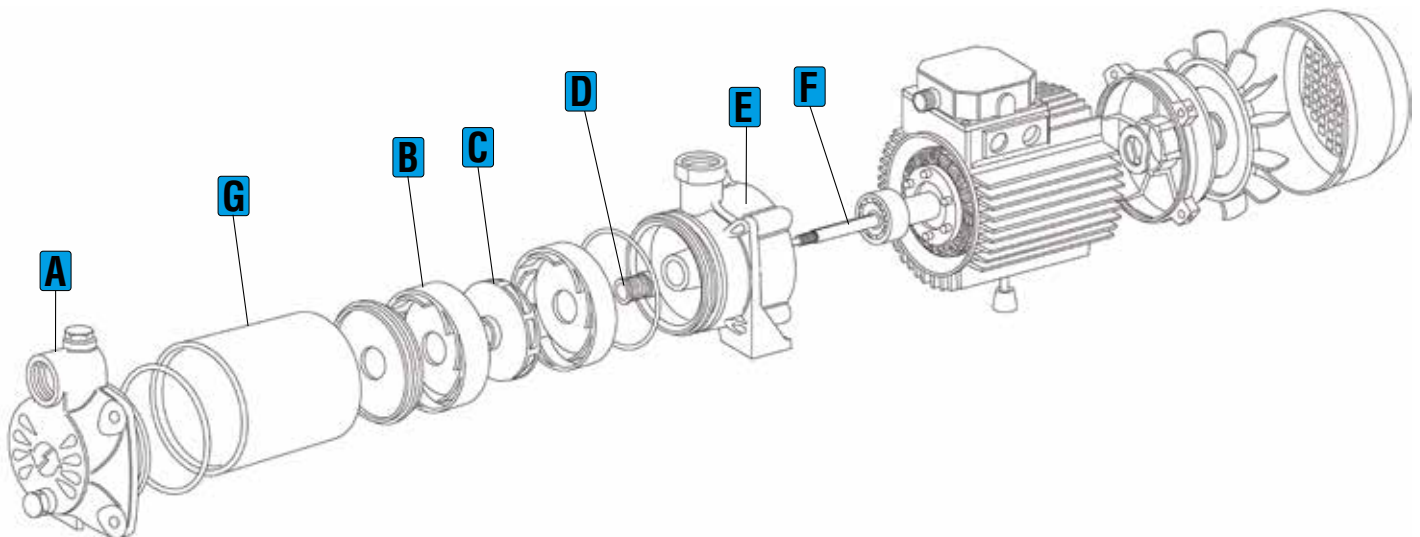

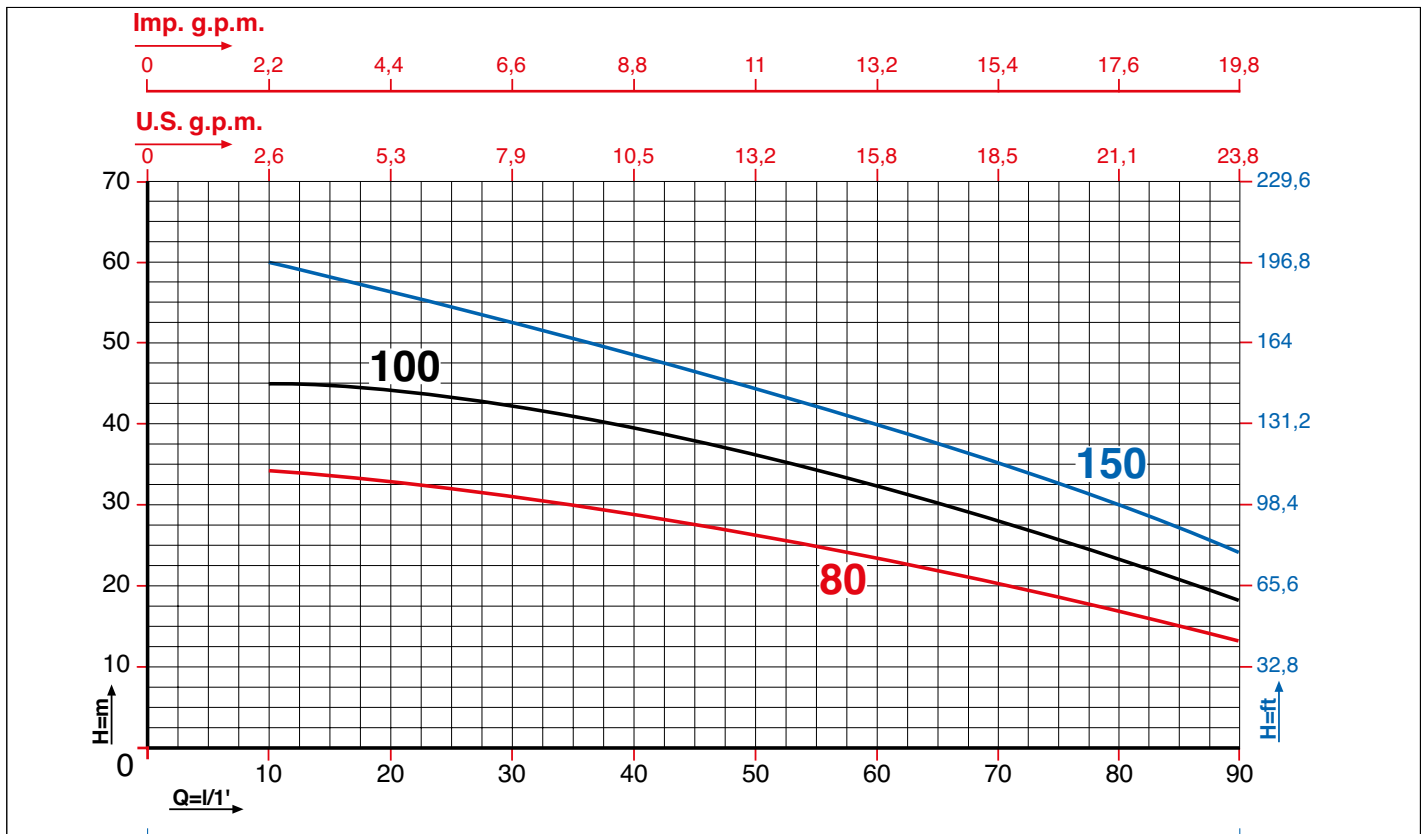

Caratteristiche di funzionamento a 2800 rpm 50Hz e 3450 rpm 60Hz - Performances at 2800 rpm 50 Hz and 3450 rpm 60 Hz
 Le prestazioni valgono per liquidi con densità $\rho = 1,0 \text{ kg/dm}^3$ ed una viscosità $\nu = 1 \text{ mm}^2/\text{s}$ / The performance data holds true for liquids with a $\rho = 1,0 \text{ kg/dm}^3$ density and a $\nu = 1 \text{ mm}^2/\text{s}$ viscosity.

MODELLO MODEL	VOLTAGGIO VOLTAGE 50 Hz	DATI ELETTRICI / ELECTRICAL DATA						DATI IDRAULICI / HYDRAULIC DATA										
		P1 max		P2 nom.		I max	Condensatore Capacitor		m ³ /h	0,6	1,2	1,8	2,4	3	3,6	4,2	4,8	5,4
		kW	kW	HP	Ampere	µF	VC	l/min.	10	20	30	40	50	60	70	80	90	
RM 80 M	1 x 220-230V	0,8	0,6	0,8	3,5	16,0	450	H (m)	34,0	33,0	31,0	38,5	26,5	23,0	20,0	17,0	13,0	
RM 100 M	1 x 220-230V	1,0	0,7	1,0	4,8	20,0	450		45,0	44,0	43,0	39,0	36,0	33,0	29,5	23,5	18,0	
RM 100 T	3 x 380-400V	1,0	0,7	1,0	2,2	---	---		45,0	44,0	43,0	39,0	36,0	33,0	29,5	23,5	18,0	
RM 150 M	1 x 220-230V	1,4	1,1	1,5	6,2	20,0	450		60,0	56,0	53,0	48,5	44,0	40,0	35,0	30,0	24,0	
RM 150 T	3 x 380-400V	1,4	1,1	1,5	3,0	---	---		60,0	56,0	53,0	48,5	44,0	40,0	35,0	30,0	24,0	
									PREVALENZA TOTALE in METRI COLONNA ACQUA / TOTAL PUMP HEAD AND WATER COLUMN HEIGHT in m.									

DIMENSIONI e PESI / SIZE AND WEIGHT DATA:

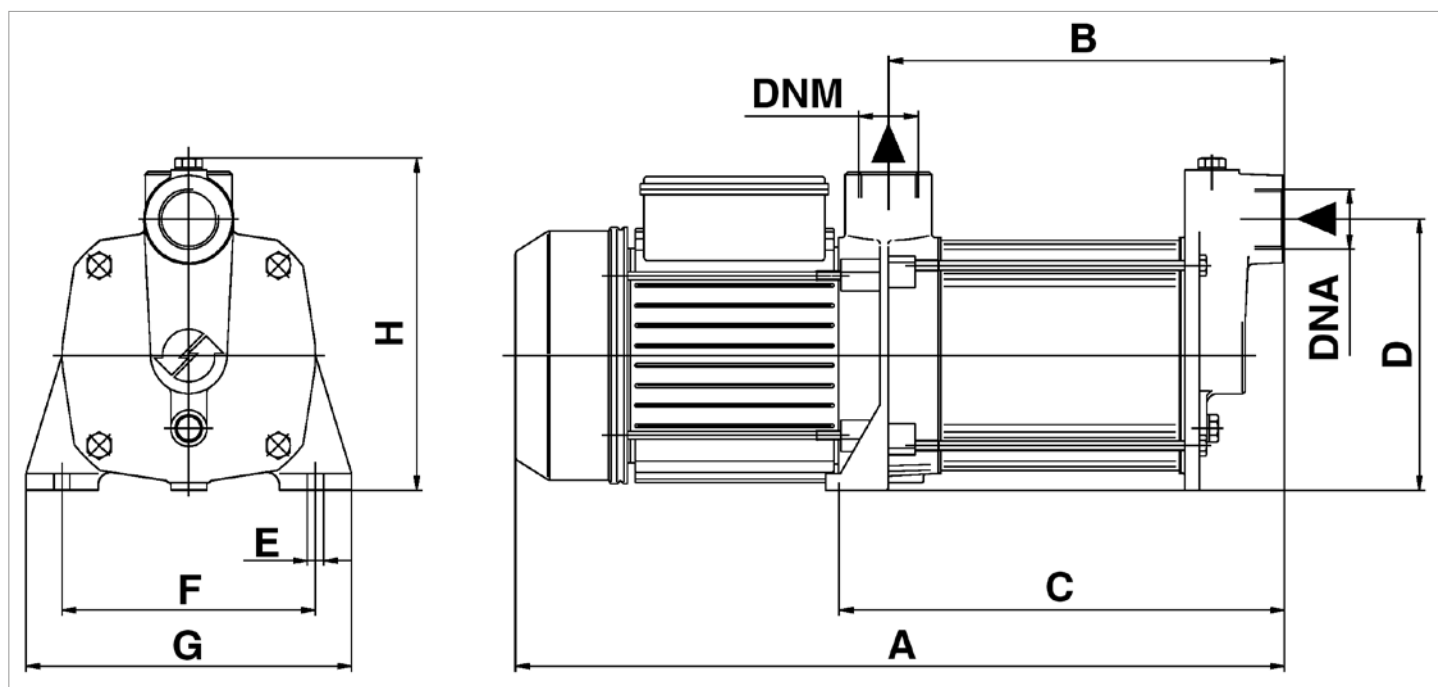
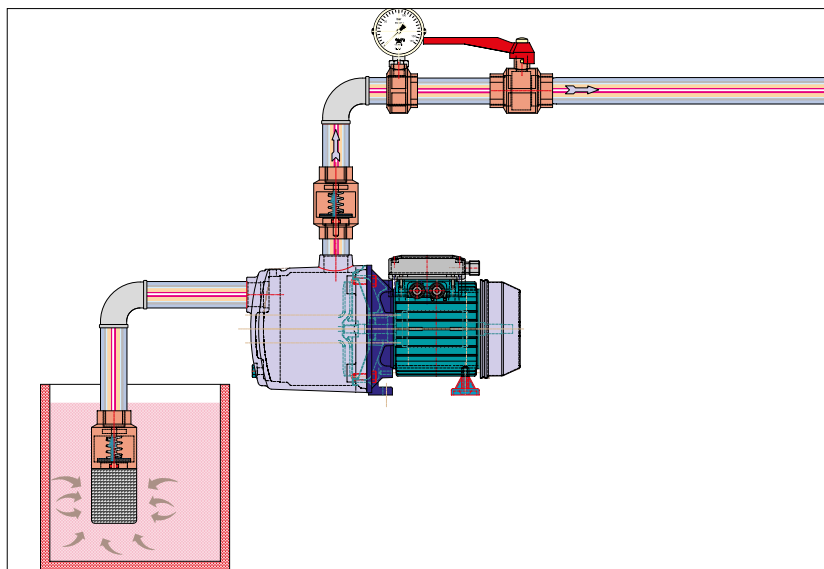
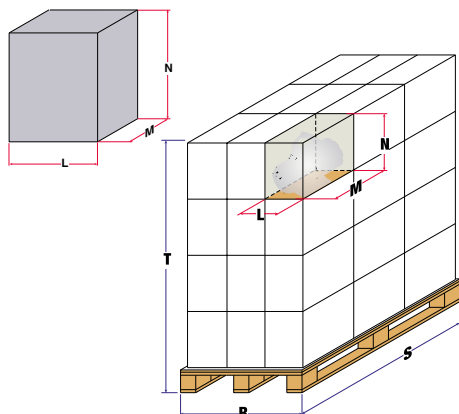

MODELLO / MODEL	DIMENSIONI POMPA in mm. / PUMP DIMENSIONS in mm.									
	DNA	DNM	A	B	C	D	E	F	G	H
RM 80	1"	1"	375	170	195	150	9,5	140	180	185
RM 100	1"	1"	400	194	220	150	9,5	140	180	185
RM 150	1"	1"	420	218	245	150	9,5	140	180	185

MODELLO MODEL	DIMENSIONI SCATOLA / PACKING DIMENSIONS			
	L mm	M mm	N mm	Peso / Weight Kg
RM 80	445	200	210	13,2
RM 100	445	200	210	14,5
RM 150	445	200	210	14,8

RMX



ELETTROPOMPE CENTRIFUGHE MULTICELLULARI INTEGRALMENTE IN ACCIAIO INOX AISI304 CENTRIFUGAL MULTISTAGE ELECTRIC STAINLESS STEEL PUMPS

PREVALENZA : 34,5 mt. ÷ 56,0 mt.
PORTATA : 4,2 m³/h ÷ 10,8 mt.
POTENZA NOMINALE : 0,55 kW (0,75HP) ÷ 1,1 kW (1,5HP)

PUMP HEAD : 34,5 m ÷ 56,0 m.
DELIVERY : 4,2 m³/h ÷ 10,8 mt.
RATED HORSEPOWER : 0,55 kW (0,75HP) ÷ 1,1 kW (1,5HP)

APPLICAZIONI

- PRESSURIZZAZIONE DI IMPIANTI DOMESTICI E PICCOLA IRRIGAZIONE.
- MOVIMENTAZIONE DI LIQUIDI NON AGGRESSIVI PER USI CIVILI ED INDUSTRIALI.
- IMPIANTI DI LAVAGGIO, INSERIMENTO SU MACCHINARI PIU' COMPLESSI PER USI INDUSTRIALI.
- PARTICOLARMENTE ADATTE PER IMPIANTI AUTOMATICI COMANDATI DA REGOLATORI DI FLUSSO INVERTER.

APPLICATIONS

- FOR DOMESTIC SYSTEMS AND SMALL IRRIGATION SYSTEM PRESSURISATION.
- HANDLING OF NON AGGRESSIVE CIVIL AND INDUSTRIAL LIQUIDS
- FOR WASHING SYSTEMS AND FOR INSERTION INTO COMPLEX INDUSTRIAL MACHINERY AND LINES.
- PARTICULARLY SUITABLE FOR AUTOMATIC SYSTEMS CONTROLLED BY PRESSURE REGULATOR OR INVERTER.



CARATTERISTICHE DI COSTRUZIONE:

- MOTORE ELETTRICO AD INDUZIONE A 2 POLI
- GRADO DI PROTEZIONE IP 55.
- CLASSE DI ISOLAMENTO: F.
- TEMPERATURA MAX.LIQUIDO POMPATO: 35°C.
- VERSIONI: Monofase: 220-230V/50Hz o 220-230V/60Hz con protettore termico incorporato e condensatore permanentemente inserito.
- POTENZA MOTORE: DA 0,75Hp A 1,5HP MONOFASE.

SPECIALI VOLTAGGI E FREQUENZE A RICHIESTA.

DESIGN ENGINEERING:

- TWO-POLE INDUCTION MOTOR
- IP 55 PROTECTION CLASS.
- CLASS "F" INSULATION.
- MAX. PUMPED LIQUID TEMPERATURE: 35°C.
- V ERSIONS: Single Phase: 220-230V/50Hz with built in thermal protection and permanent capacitor.
- MOTOR POWER: From 0,75Hp to 1,5Hp only single phase versions.

CUSTOMISED VOLTAGE AND FREQUENCY RATING AVAILABLE ON DEMAND.

TABELLA MATERIALI - MATERIALS TABLE:

Pos.	Componente / Component	Materiale / Materials
A	Corpo pompa / Pump body	ACCIAIO INOX / STAINLESS STEEL
B	Diffusore / Diffuser	ACCIAIO INOX / STAINLESS STEEL
C	Girante / Impeller	ACCIAIO INOX / STAINLESS STEEL
D	Tenuta meccanica / Mechanical Seal	CERAMICA - GRAFITE - VITON/ CERAMIC- GRAPHITE - VITON
E	Albero (lato pompa) / Shaft (pump face)	ACCIAIO INOX / STAINLESS STEEL

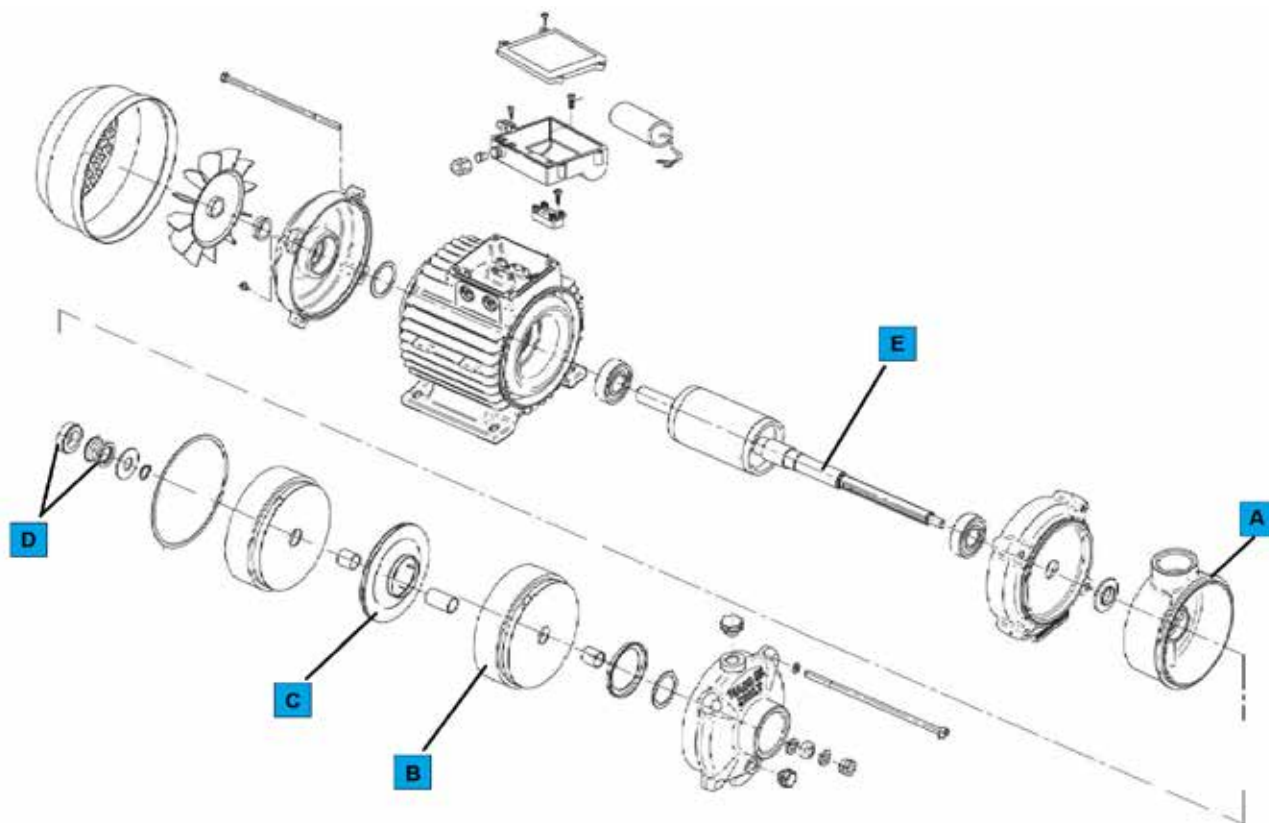

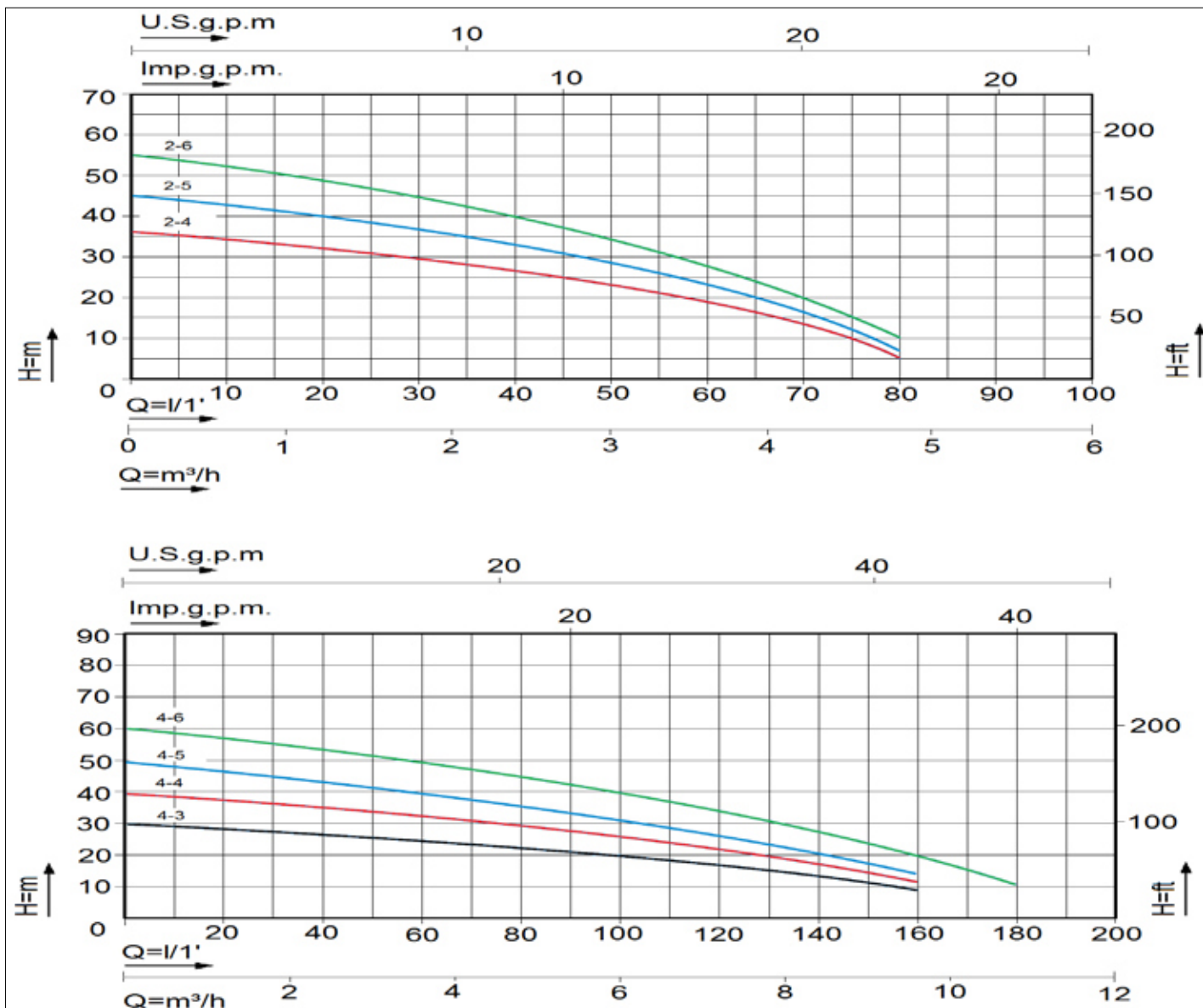

Caratteristiche di funzionamento a 2800 rpm 50Hz e 3450 rpm 60Hz - Performances at 2800 rpm 50 Hz and 3450 rpm 60 Hz

Le prestazioni valgono per liquidi con densità $\rho = 1,0 \text{ kg/dm}^3$ ed una viscosità $\nu = 1 \text{ mm}^2/\text{s}$ / The performance data holds true for liquids with a $\rho = 1,0 \text{ kg/dm}^3$ density and a $\nu = 1 \text{ mm}^2/\text{s}$ viscosity.

MODELLO MODEL	DATI ELETTRICI / ELECTRICAL DATA					DATI IDRAULICI / HYDRAULIC DATA									
	P2 nom.		P1 max	I max	I max	m³/h	0	0,6	1,2	1,8	2,4	3,0	3,6	4,2	4,8
	kW	HP	kW	1x230V	3x400V	l/min.	0	10	20	30	40	50	60	70	80
RMX 2-4	0,55	0,75	0,65	2,9	1,3	H (m)	36	34,5	33	31	27	23	18	12	---
RMX 2-5	0,55	0,75	0,75	3,3	1,4		45	43	40	37	33	28	22	14	6
RMX 2-6	0,75	1	0,85	3,7	1,7		55	53	49	45	40	34	27	20	10

MODELLO MODEL	DATI ELETTRICI / ELECTRICAL DATA					DATI IDRAULICI / HYDRAULIC DATA									
	P2 nom.		P1 max	I max	I max	m³/h	0	1,2	2,4	3,6	4,8	6	8,4	9,6	10,8
	kW	HP	kW	1x230V	3x400V	l/min.	0	20	40	60	80	100	140	160	180
RMX 4-3	0,55	0,75	0,9	3,9	1,8	H (m)	30	28,5	26,5	24,5	22,5	19,5	13	8	---
RMX 4-4	0,75	1	1,1	4,8	2		39,5	38	35	32	29	25	16	11	---
RMX 4-5	0,75	1	1,3	5,7	2,3		49,5	47	44	40	36	32	21	14	---
RMX 4-6	1,1	1,5	1,6	7	2,8		60	56	52	48	44	38,5	26	18	10

PRELEVANZA TOTALE IN METRI COLONNA ACQUA
TOTAL PUMP HEAD AND WATER COLUMN HEIGHT IN m.

DIMENSIONI e PESI / SIZE AND WEIGHT DATA :

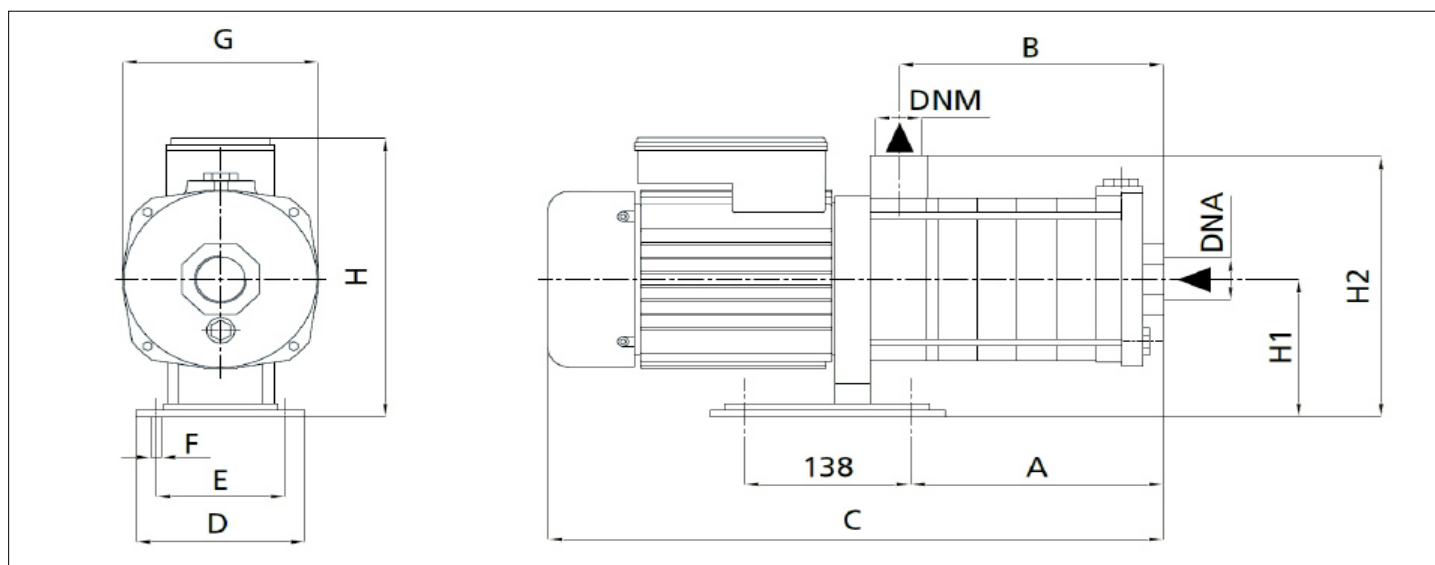
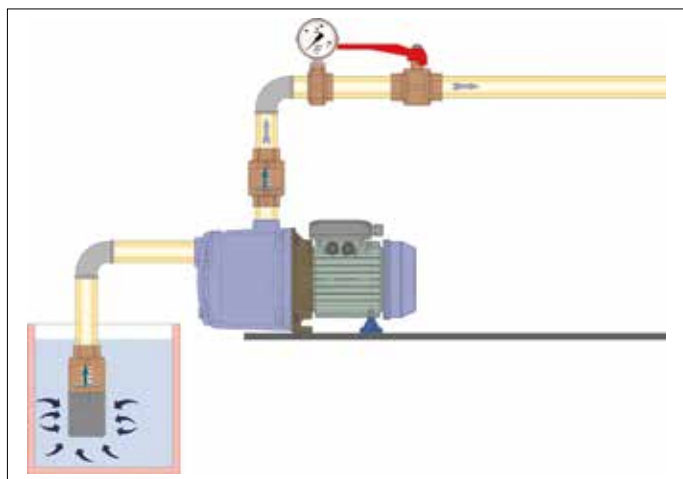
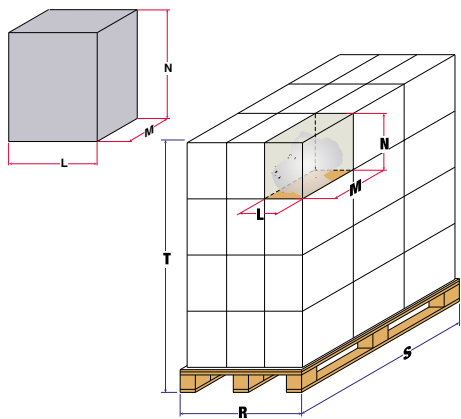

MODELLO MODEL	DIMENSIONI in mm. / PUMP DIMENSION IN mm.											
	DNA	DNM	A	B	C	D	E	F	G	H	H1	H2
RMX 2-4	1"	1"	126	136	362	130	108	9	143	216	90	162
RMX 2-5	1"	1"	144	154	380	130	108	9	143	216	90	162
RMX 2-6	1"	1"	162	172	398	130	108	9	143	216	90	162
RMX 4-3	1 1/4"	1"	126	136	362	130	108	9	143	216	90	162
RMX 4-4	1 1/4"	1"	153	163	389	130	108	9	143	216	90	162
RMX 4-5	1 1/4"	1"	180	190	416	130	108	9	143	216	90	162
RMX 4-6	1 1/4"	1"	207	217	443	130	108	9	143	216	90	162

MODELLO MODEL	DIMENSIONI SCATOLA / PACKING DIMENSIONS			
	L mm	M mm	N mm	PESO/Weight kg
RMX 2-4 / 2-5	145	435	235	9,5
RMX 2-6 / 4-4	145	435	235	10,5
RMX 4-3	145	435	235	10
RMX 4-5	145	435	235	11,5
RMX 4-6	145	495	235	12



ELETTROPOMPE AUTODESCANTI A CANALE LATERALE IN OTTONE SELF-PRIMING SIDE CHANNEL PUMPS IN BRASS

PREVALENZA : 1,0 mt ÷ 20,0 mt.
PORTATA : 1,7 m³/h ÷ 7,5 m³/h
POTENZA NOMINALE : 0,4 kW (0,5HP) ÷ 1,9 kW (2,5HP)

PUMP HEAD : 1,0 mt ÷ 20,0 mt
DELIVERY : 1,7 m³/h ÷ 7,5 m³/h
RATED HORSEPOWER : 0,4 kW (0,5HP) ÷ 1,9 kW (2,5HP)

APPLICAZIONI

- La migliore soluzione per l'aspirazione e il travaso di liquidi, grazie alla forte capacità di autoadescamento, alla possibilità di funzionamento anche con presenza discontinua del liquido in aspirazione e alla invertibilità del flusso. L'innovativa costruzione stagna del corpo pompa evita il contatto fra il liquido e la parte motore e impedisce trasudamenti. Sono vere pompe multifunzione, in grado di risolvere molteplici problemi di pompaggio, in campo domestico, agricolo e industriale.

APPLICATIONS

- The best solution for liquid transfers because of the high self-priming capability, the possibility to operate with discontinuous presence of the liquid at the suction and the reversibility of the flow. The innovative tight structure of the pump body avoids the contact between the liquid and the motor and prevents losses. They are real multipurpose pumps, able to solve many pumping problems, at home, in agriculture and industry.

CARATTERISTICHE DI COSTRUZIONE:

- Corpo pompa e girante in ottone CB754S.
- Controflangia in acciaio inox AISI 304.
- Albero in acciaio inox AISI 316.
- Corredate di un raccordo portagomma dritto e un raccordo portagomma curvo in ottone.
- Tenuta sull'albero ad anello in NBR con molla inox, guarnizioni in NBR.
- Motore asincrono monofase 220 Volt / 50 Hz con invertitore e cavo, protezione IP 44, eventuale protezione dai sovraccarichi a cura dell'utilizzatore; voltaggi diverse sono disponibili su richiesta.
- Altezza di adescamento 6 metri.
- All'installazione occorre riempire la pompa di liquido, successivamente questa operazione non è più necessaria.
- Inversione del flusso tramite interruttoreinvertitore a bascula (vedi disegno).
- Possibilità di funzionamento per brevi periodi con tubazioni chiuse.
- Possibilità di funzionamento con presenza discontinua del liquido in aspirazione.

SPECIFICHE SUL LIQUIDO:

- Non aggressivo nei confronti dei materiali del corpo pompante e delle guarnizioni.
- Privo di particelle dure (es. sabbia).
- Temperatura max 90°C.
- Densità max 1.1 g/cm³.
- Esempi d'uso: acqua dolce, acqua di mare, gasolio, olio, anticrittogamici, etc.
- Non usare con benzina, solventi e, in generale, in ambienti con rischio di esplosione e incendio.

DESIGN ENGINEERING:

- Pump body and impeller in CB754S brass.
- Counterflange in AISI 304 stainless steel.
- Shaft in AISI 316 stainless steel.
- Supplied with one straight hose fitting and one 90° hose fitting in brass.
- Shaft sealing by lip seal in NBR with stainless steel spring, gaskets in NBR.
- Asynchronous single-phase motor, 220 Volts / 50 Hz, with switchreverser and cable, protection IP 44, without overload protection; different voltages are available on request.
- Height of priming 6 meters.
- When installing, it is necessary to fill the pump with liquid; afterwards, this operation is no longer required.
- Possibility to reverse the flow by the switchreverser (see drawing).
- Possibility to run with completely closed delivery pipe for a short time.
- Possibility to operate with discontinuous presence of the liquid at the suction.

DESIGN ENGINEERING:

- Not aggressive towards the materials forming the pumping body and the gaskets.
- Without hard particles (e. g. sand).
- Max temperature 90° C.
- Max density 1.1 g/cm³.
- Examples: water, sea water, gasoil, oil, anticryptogamics, etc.
- Do not use with petrol, solvents and, in general, in places presenting the risk of explosion and fire.

MODELLO / MODEL	HP	R.p.m	Bocche Hoses	Ø Raccordi	Adescam. (m)	DATI IDRAULICI / HYDRAULIC DATA					Leq.A	
						1 m	5 m	10 m	15 m	20 m		
1 x 220 50Hz												
GPV.PEM20	0,5	2800	3/4"	20	6	28	22	15	9	3	77	
GPV.PEM25	0,6	1400	1"	25	6	47	32	13	-	-	71	
GPV.PEM30	1,0	1400	1 1/2"	30	6	86	67	42	13	-	74	
GPV.PEM40	1,2	1400	1 1/2"	40	6	125	97	64	15	-	77	

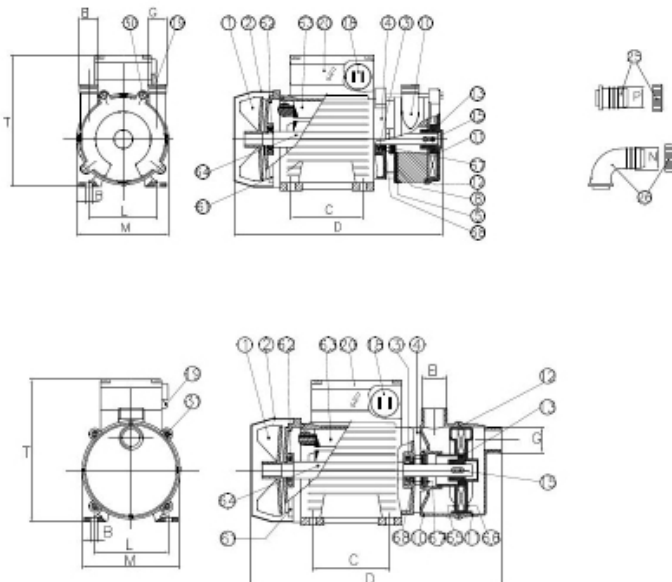
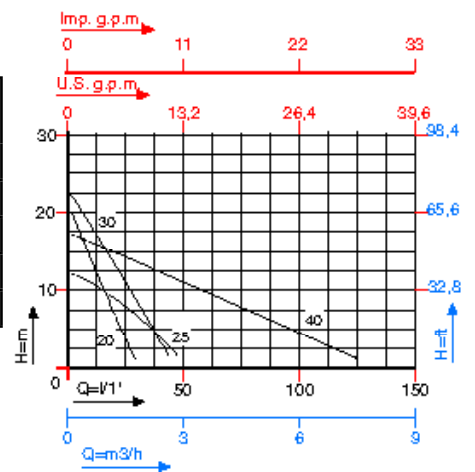

TYPE	B	C	D	EG	L	M	NP	T	Kg
GPV.PEM20	7	80	250	3/4"	100	120	20	195	5.8
GPV.PEM25	7	90	325	1"	113	141	25	210	9
GPV.PEM30	7	90	375	1 1/2"	113	160	30	230	10.5
GPV.PEM40	7	90	375	1 1/2"	113	165	40	230	11.6



ELETTROPOMPE AUTODESCANTI A CANALE LATERALE IN ACCIAI INOX AISI316 SELF-PRIMING SIDE CHANNEL PUMPS IN AISI316 STAINLESS STEEL

PREVALENZA : 1,0 mt ÷ 30,0 mt.
PORTATA : 0,5 m³/h ÷ 12 m³/h
POTENZA NOMINALE : 0,15 kW (0,2HP) ÷ 1,9 kW (2,5HP)

PUMP HEAD : 1,0 mt ÷ 30,0 mt
DELIVERY : 0,5 m³/h ÷ 12 m³/h
RATED HORSEPOWER : 0,15 kW (0,2HP) ÷ 1,9 kW (2,5HP)

APPLICAZIONI

- La migliore soluzione per l'aspirazione e il travaso di liquidi, grazie alla forte capacità di autoadescamento e alla possibilità di funzionamento anche con presenza discontinua del liquido in aspirazione. Sono progettate per l'impiego in enologia (vino, mosti), industria alimentare (olio, aceto, salamoia, succhi di frutta, mosto di birra, latte), agricoltura (anticrittogamici, concimi liquidi), nautica (acqua di mare), industria chimica (liquidi corrosivi). Per ogni applicazione occorre verificare l'idoneità e scegliere le guarnizioni opportune.

APPLICATIONS

- The best solution for liquid transfers because of the high self-priming capability and the possibility to operate with discontinuous presence of the liquid at the suction. They are designed for use in oenology (wine, musts), food industry (oil, vinegar, brine, fruit juices, beer must, milk), agriculture (anticryptogamic and fertilizing fluids), nautical field (sea water) chemical industry (corrosive liquids). For any application it is necessary to verify fitness and to choose suitable gaskets.

CARATTERISTICHE DI COSTRUZIONE:

- Corpo pompa, girante e albero in acciaio inox AISI 316.
- Tenuta meccanica ceramica/grafite/NBR e guarnizioni in NBR; altri tipi sono disponibili su richiesta (vedere pagina ACCESSORI).
- Motore asincrono monofase (ALM) o trifase (ALT) con invertitore e cavo, protezione IP 44, protezione dai sovraccarichi a cura dell'utilizzatore; allestimento con morsettiera o protezione IP 55 su richiesta.
- Altezza di adescamento 6 metri
- All'installazione occorre riempire la pompa di liquido, successivamente questa operazione non è più necessaria.
- Inversione del flusso tramite interruttoreinvertitore rotativo professionale.
- Possibilità di funzionamento per brevi periodi con tubazione di mandata completamente chiusa.
- Voltaggi speciali disponibili su richiesta.

SPECIFICHE SUL LIQUIDO:

- Privo di particelle dure (es. sabbia)
- Temperatura max 90° C (guarnizioni in EPDM: 110° C, guarnizioni in Viton: 130° C).
- Densità max 1.1 g/cm³.
- Non usare con benzina, solventi e, in generale, in ambienti con rischio di esplosione e incendio.

MODELLO / MODEL		HP	R.p.m	Bocche Hoses	DATI IDRAULICI / HYDRAULIC DATA					Leq.A
1 x 220 50Hz	3 x 380 50Hz				1 m	5 m	10 m	20 m	30 m	
GPV.PXM20	GPV.PXT20	0,5	2800	3/4"	25	19	12	4	-	64
GPV.PXM20L	GPV.PXT20L	0,2	1400	3/4"	8	-	-	-	-	60
GPV.PXM25MS	GPV.PXT25MS	1,2	2800	1"	54	50	44	26	6	86
GPV.PXM25	GPV.PXT25	0,6	1400	1"	43	23	-	-	-	65
GPV.PXM30L	GPV.PXT30L	1,0	1400	1"1/2	92	68	31	-	-	75
GPV.PXM30	GPV.PXT30	2,0	2800	1"	81	76	67	46	23	78
GPV.PXM40	GPV.PXT40	1,2	1400	1"1/2	130	92	53	-	-	79
GPV.PXM50		2,0	1400	2"	197	164	132	67	-	83
	GPV.PXT50	2,5	1400	2"	197	164	132	67	-	83

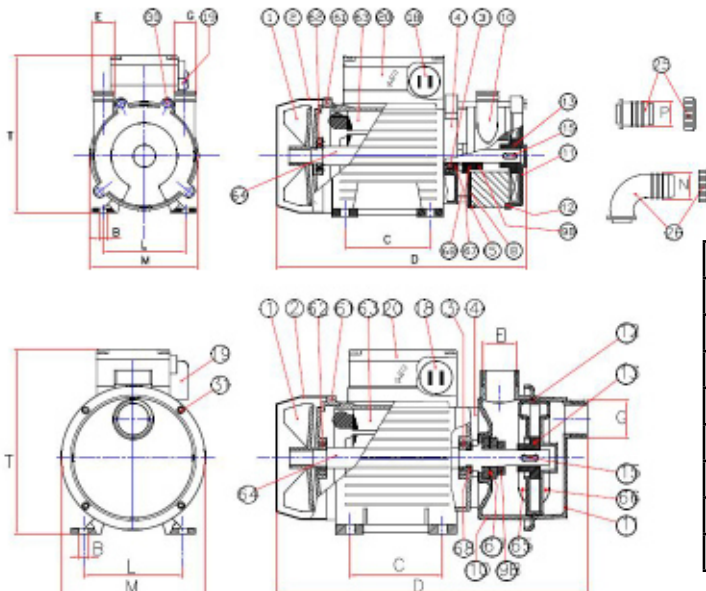

DESIGN ENGINEERING:

- Pump body, impeller and shaft in AISI 316 stainless steel.
- Mechanical seal ceramic/graphite/NBR and gaskets in NBR; other types are available on request (see sheet ACCESSORIES).
- Asynchronous single-phase (ALM) or three-phase (ALT) motor with switch-reverser and cable, protection IP 44, without overload protection; on request terminal board or protection IP 55.
- Height of priming 6 meters.
- When installing, it is necessary to fill the pump with liquid; afterwards, this operation is no longer required.
- Possibility to reverse the flow by the professional rotary switchreverser.
- Possibility to run with completely closed delivery pipe for a short time.
- Special voltages available on request.

DESIGN ENGINEERING:

- Without hard particles (e. g. sand)
- Max temperature 90° C (gaskets in EPDM: 110° C, gaskets in Viton: 130° C).
- Max density 1.1 g/cm³.
- Do not use with petrol, solvents and, in general, in places presenting the risk of explosion and fire.

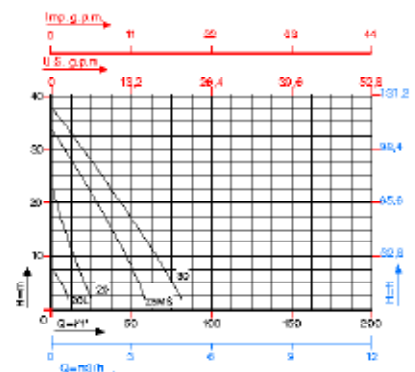
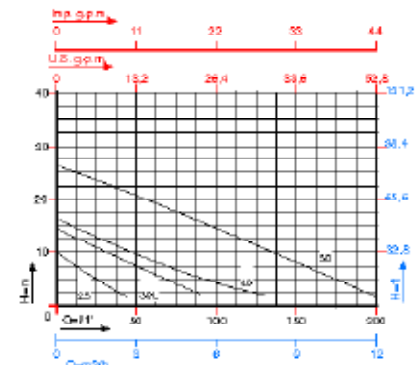

TYPE		B	C	D	EG	L	M	N P	T	Kg
GPV.PXM20	GPV.PXT20	7	80	250	3/4"	100	150	20	195	5.2
GPV.PXM20L	GPV.PXT20L	7	80	250	3/4"	100	150	20	195	5.3
GPV.PXM25MS	GPV.PXT25MS	9	90	325	1"	113	155	25	210	7.8
GPV.PXM25	GPV.PXT25	9	90	325	1"	113	155	25	210	9.8
GPV.PXM30L	GPV.PXT30L	9	100	390	1"1/2	126	162	40	230	13.6
GPV.PXM30	GPV.PXT30	9	100	350	1"	126	158	30	230	13.5
GPV.PXM40	GPV.PXT40	9	100	390	1"1/2	126	162	40	230	13.9
GPV.PXM50	GPV.PXT50	9	125	438	2"	140	200	50	250	20.5

CR



ELETTROPOMPE CENTRIFUGHE MONOBLOCCO MONOBLOCK CENTRIFUGAL PUMPS

PREVALENZA : 24,0 mt. ÷ 91,5 mt.
PORTATA : 27,0 m³/h ÷ 240 m³/h
POTENZA NOMINALE : 1,5 kW (2,0HP) ÷ 37,0 kW (50HP)

PUMP HEAD : 24,0 mt ÷ 91,5 mt
DELIVERY : 27,0 m³/h ÷ 240 m³/h
RATED HORSEPOWER : 1,5 kW (2,0HP) ÷ 37,0 kW (50,0HP)

APPLICAZIONI

- APPROVVIGIONAMENTI D'ACQUA, IRRIGAZIONI A PIOGGIA OD A SCORRIMENTO.
- MOVIMENTAZIONE DI LIQUIDI NON AGGRESSIVI PER USI CIVILI ED INDUSTRIALI.
- ALIMENTAZIONI AUTOCLAVI E SOPRAELEVAZIONI DI PRESSIONE RISCALDAMENTO E CONDIZIONAMENTO.

APPLICATIONS

- WATER SUPPLY, SPRAY OR FLOWING IRRIGATION.
- HANDLING OF NON AGGRESSIVE CIVIL AND INDUSTRIAL LIQUIDS.
- AUTOCLAVE FEE, HIGH PRESSURE SYSTEM, HEATING, CONDITIONING



ARVEN[®]
WATER PUMPS

CARATTERISTICHE DI COSTRUZIONE:

- MOTORE CHIUSO CON VENTILAZIONE ESTERNA E CASSA ALETTATA IN LEGA DI ALLUMINIO.
- GRADO DI PROTEZIONE IP 55.
- CLASSE DI ISOLAMENTO: F.
- TEMPERATURA MAX.LIQUIDO POMPATO: 35°C.
- VERSIONI: Monofase: 220 - 230V/50Hz o 220 - 230V/60Hz con protettore termico incorporato e condensatore permanentemente inserito.
Trifase: 220 - 230V/50Hz e 380 - 400V/50Hz o 220 - 230V/60Hz e 380 - 400V/60Hz con protezione da sovraccarico a cura dell'utente.
- POTENZA MOTORE: DA 2Hp a 5,5 Hp VERSIONE MONOFASE E TRIFASE.
DA 7,5 Hp a 50 Hp SOLO VERSIONE TRIFASE

SPECIALI VOLTAGGI E FREQUENZE A RICHIESTA.

DESIGN ENGINEERING:

- SEALED MOTOR WITH EXTERNAL VENTILATION AND FINNED ALUMINIUM ALLOY CASING.
- IP 55 PROTECTION CLASS.
- CLASS "F" INSULATION.
- MAX. PUMPED LIQUID TEMPERATURE: 35°C.
- VERSIONS: Single Phase: 220 - 230 V/50 Hz with built in thermal protection and permanent capacitor.
Three Phase: 220 - 230V/50Hz or 380- 400V/50Hz and 220 - 230V/60Hz or 380 - 400V/60Hz with overload protection care of the User.
- MOTOR POWER: From 2Hp to 5,5Hp single phase versions and three versions
From 7,5 Hp to 50 Hp only three phases versions

CUSTOMISED VOLTAGE AND FREQUENCY RATING AVAILABLE ON DEMAND.

TABELLA MATERIALI / MATERIALS TABLE:

Pos.	Componente / Component	Materiale / Materials
A	Corpo pompa / Pump body	GHISA / CAST IRON
B	Diffusore / Diffuser	GHISA / CAST IRON
C	Girante / Impeller	GHISA / CAST IRON
D	Tenuta meccanica / Mechanical Seal	CERAMICA-GRAFITE / CERAMIC-GRAPHITE
E	Flangia / Flange	GHISA / CAST IRON
F	Albero (lato pompa) / Shaft (pump face)	ACCIAIO INOX / STAINLESS STEEL

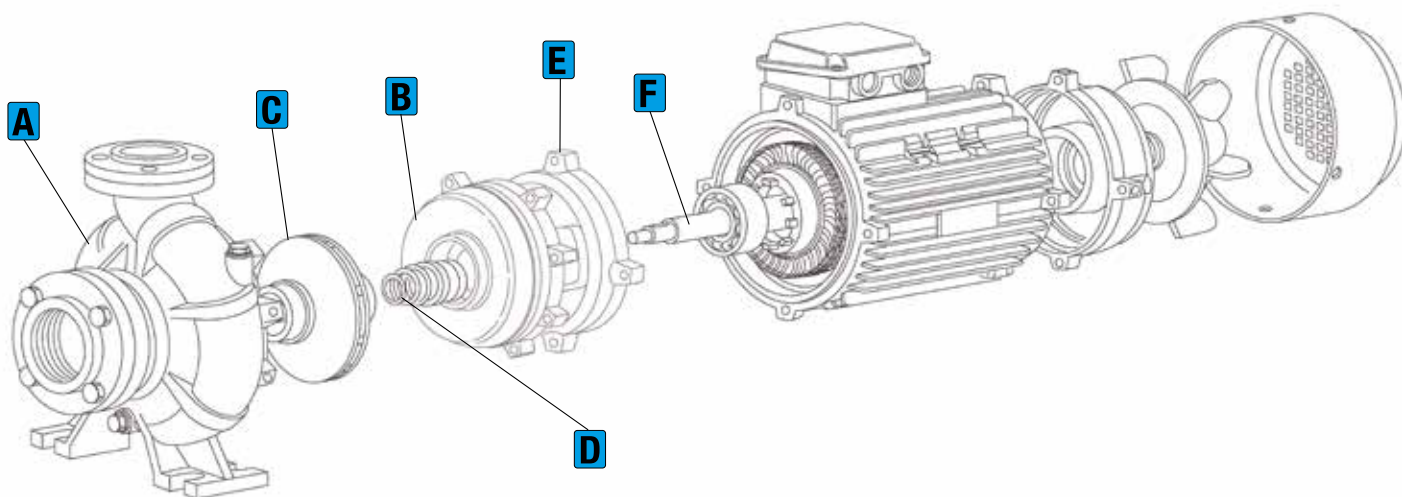

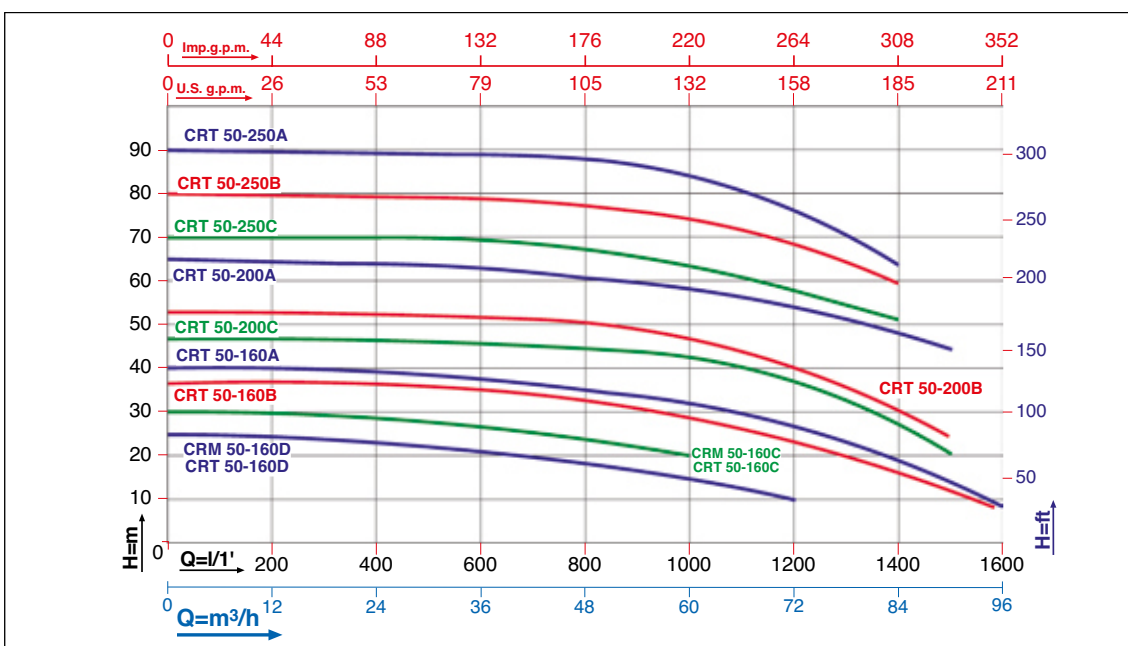
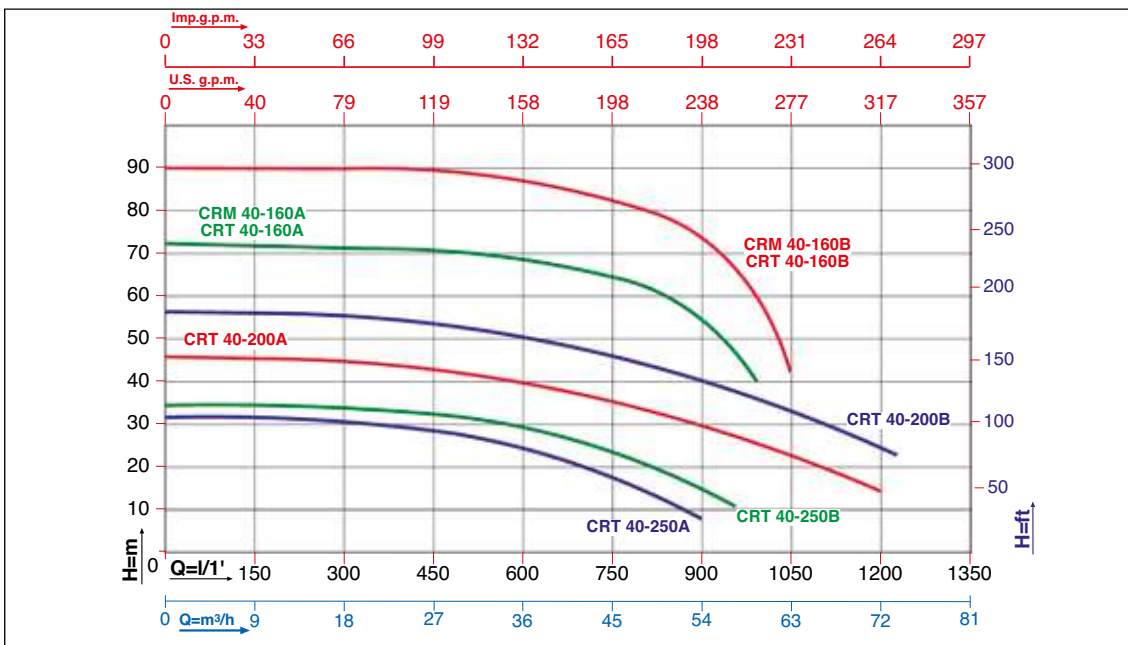
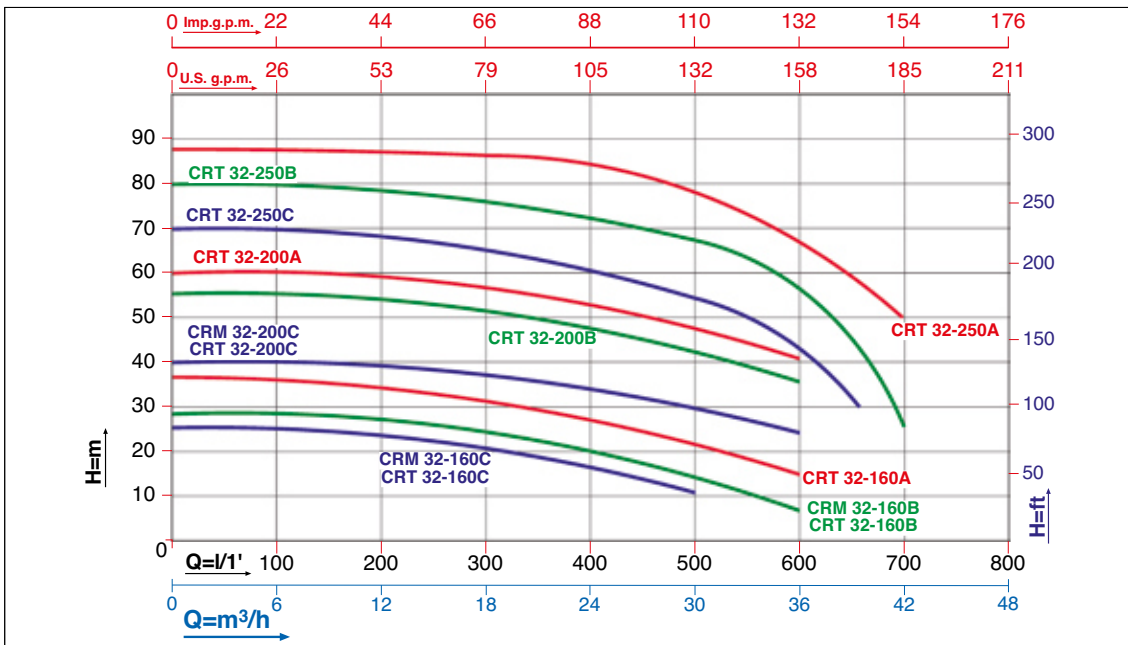

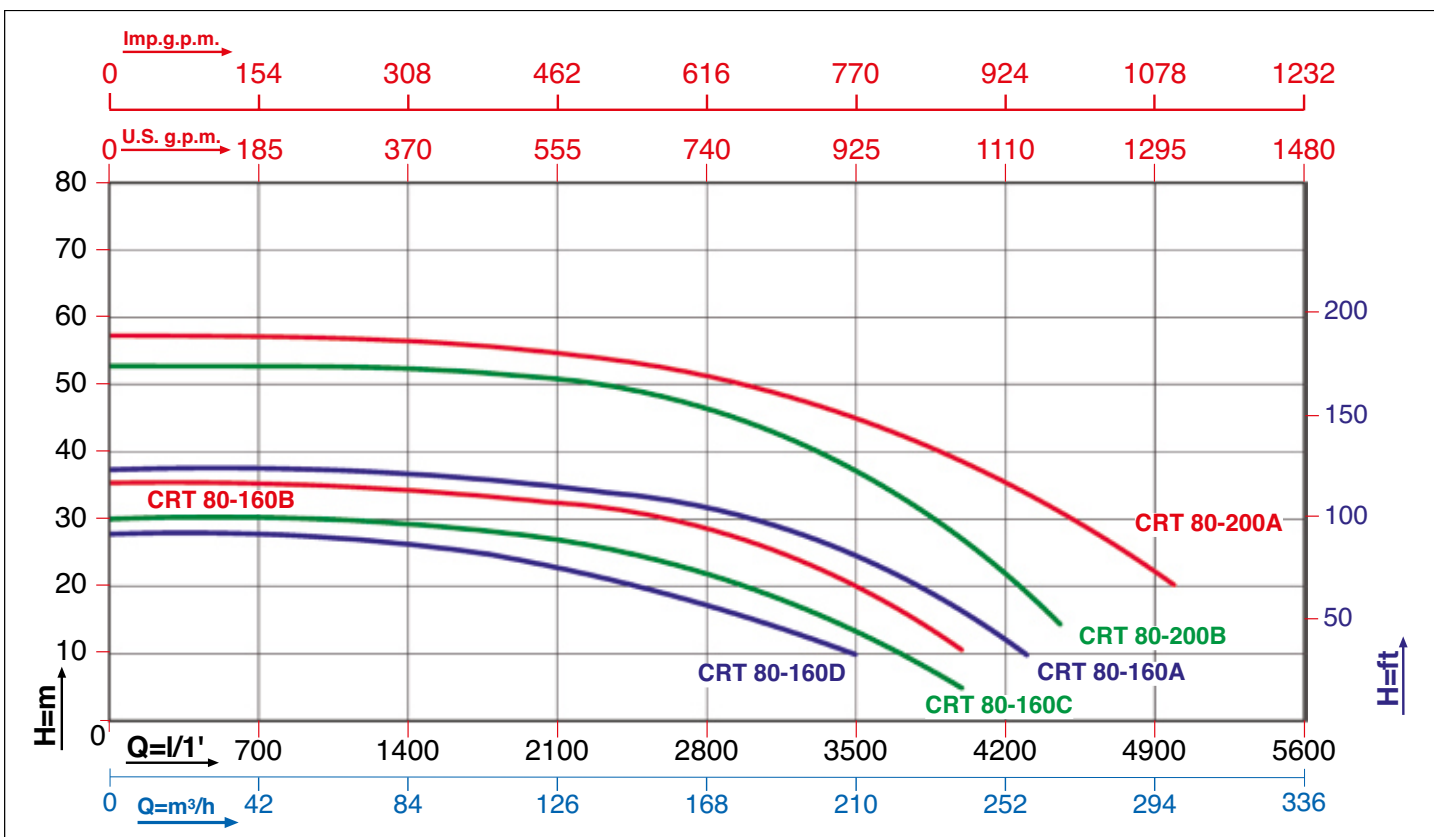
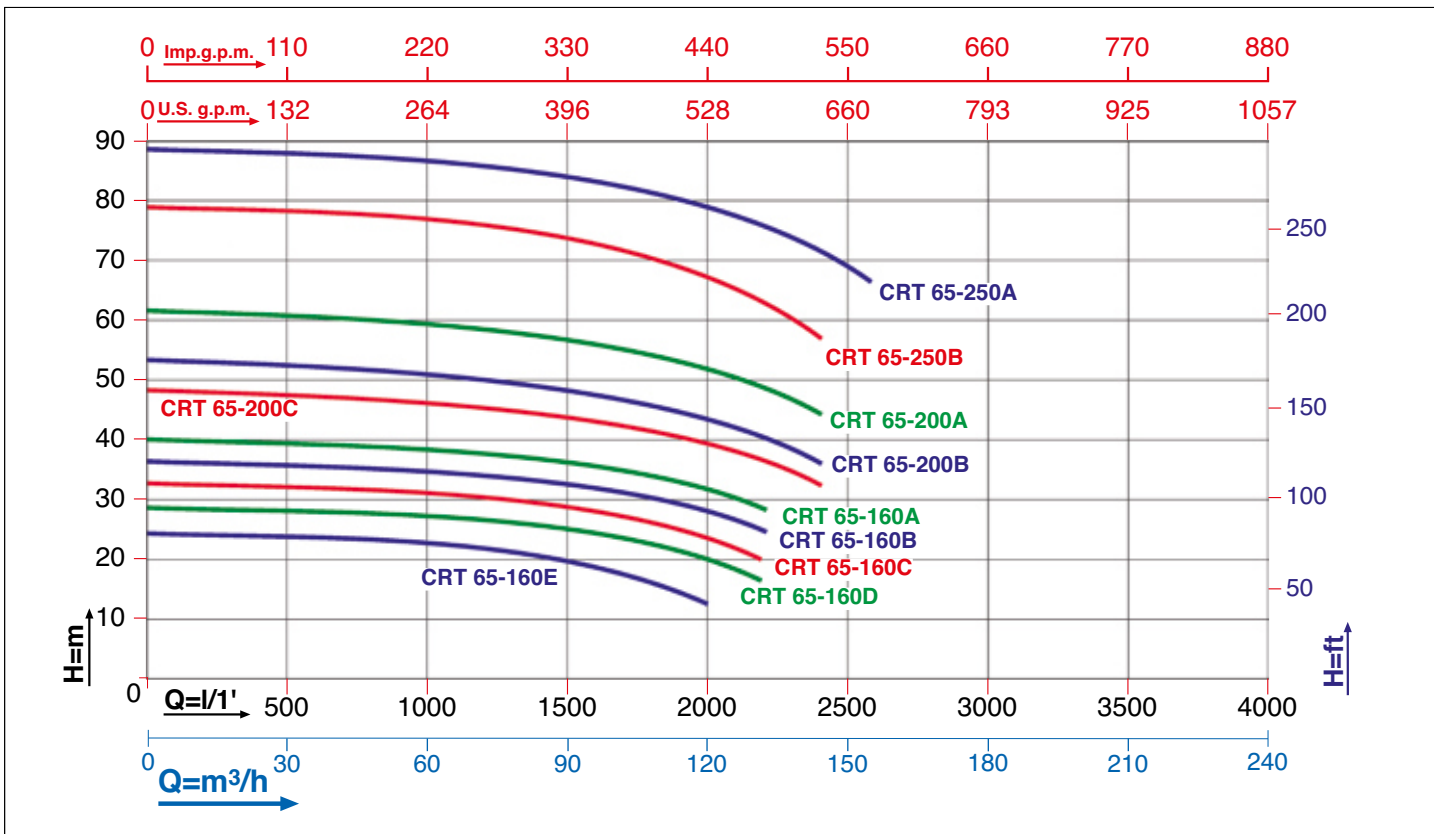

MODELLO MODEL	VOLTAGGIO VOLTAGE 50 Hz	DATI ELETTRICI / ELECTRICAL DATA						DATI IDRAULICI / HYDRAULIC DATA										
		P1max		P2 nom.		I max	Condensatore Capacitor	m³/h	6	7,5	9	12	15	18	21	24	27	30
		kW	kW	HP	Ampere	µF		VC	l/min.	100	125	150	200	250	300	350	400	450
CRM 32-160 C	1 x 220-230V	2,7	1,5	2	12,0			25,5	25,3	25	24	23	21,5	20	18	15,5	---	
CRT 32-160 C	3 x 380-400V	2,7	1,5	2	4,8	---	---	25,5	25,3	25	24	23	21,5	20	18	15,5	---	
CRM 32-160 B	1 x 220-230V	3,3	2,2	3	15,0			28,8	28,5	28	27	26	24,5	23	21,5	18,5	15,5	
CRT 32-160 B	3 x 380-400V	3,3	2,2	3	5,0	---	---	28,8	28,5	28	27	26	24,5	23	21,5	18,5	15,5	
CRT 32-160 A	3 x 380-400V	4,3	3,0	4	7,0	---	---	36,5	36	35,5	34,5	33	31,5	30	28,5	26	23,5	
CRM 32-200 C	1 x 220-230V	5,7	4,0	5,5	27,0			40,7	40,5	40	39,5	39	38	36,5	35	33	31,5	
CRT 32-200 C	3 x 380-400V	5,7	4,0	5,5	8,8	---	---	40,7	40,5	40	39,5	39	38	36,5	35	33	31,5	
CRT 32-200 B	3 x 380-400V	8,6	5,5	7,5	14,0	---	---	55,7	55,5	55	54,5	54	53	51,5	50	48	46,5	
CRT 32-200 A	3 x 380-400V	9,5	7,5	10	15,0	---	---	60,7	60,5	60	59,5	58,5	57	55,5	54	52	49,5	
CRT 32-250 C	3 x 380-400V	12,0	9,2	12,5	19,0	---	---		70	69,5	68,5	67,5	66	64,5	6,5	59,5	56	
CRT 32-250 B	3 x 380-400V	13,5	11,0	15	21,5	---	---		81	80,5	79,5	78,5	77	75,5	73,5	71	67,5	
CRT 32-250 A	3 x 380-400V	15,5	15,0	20	25	---	---		90,5	90	89,5	89	87,5	86	84	81,5	78	
CRM 40-160 B	1 x 220-230V	4,8	3,0	4	22,0					32,7	32,5	32,3	32	31,5	30,5	29,5	28	
CRT 40-160 B	3 x 380-400V	4,8	3,0	4	7,5	---	---			32,7	32,5	32,3	32	31,5	30,5	29,5	28	
CRM 40-160 A	1 x 220-230V	5,7	4,0	5,5	28,0					36,2	36	35,8	35,5	35	34	33	32	
CRT 40-160 A	3 x 380-400V	5,7	4,0	5,5	8,8	---	---			36,2	36	35,8	35,5	35	34	33	32	
CRT 40-200 B	3 x 380-400V	8,6	5,5	7,5	14,0	---	---			46,5	46	45,5	45	44,5	43,5	42,5	41,5	
CRT 40-200 A	3 x 380-400V	11,3	7,5	10	17,5	---	---			56	55,5	55	54,5	54	53	52	51	
CRT 40-250 B	3 x 380-400V	15,5	11,0	15	24,5	---	---			74	73,9	73,8	73,7	73,5	73	72	71	
CRT 40-250 A	3 x 380-400V	20,0	15,0	20	32,0	---	---			91,5	91,4	91,3	91,2	91	90,5	90	89	
CRM 50-160 D	1 x 220-230V	4,8	3,0	4	22,0									25	24,5	24	23,5	
CRT 50-160 D	3 x 380-400V	4,8	3,0	4	7,5	---	---							25	24,5	24	23,5	
CRM 50-160 C	1 x 220-230V	5,7	4,0	5,5	27,0									29,5	29,2	28,8	28,3	
CRT 50-160 C	3 x 380-400V	5,7	4,0	5,5	8,8	---	---							29,5	29,2	28,8	28,3	
CRT 50-160 B	3 x 380-400V	8,2	5,5	7,5	13,2	---	---							37	36,8	36,5	36	
CRT 50-160 A	3 x 380-400V	9,5	7,5	10	15,0	---	---							40	39,8	39,5	39	
CRT 50-200 C	3 x 380-400V	12,0	9,2	12,5	19,0	---	---								48,7	48,5	48,2	
CRT 50-200 B	3 x 380-400V	13,5	11,0	15	21,5	---	---								52,7	52,5	52,2	
CRT 50-200 A	3 x 380-400V	18,0	15,0	20	29,0	---	---								64,5	64	63,5	
CRT 50-250 C	3 x 380-400V	20,0	15,0	20	32,0	---	---									71,3	71	
CRT 50-250 B	3 x 380-400V	23,0	18,5	25	36,5	---	---									80,8	80,5	
CRT 50-250 A	3 x 380-400V	27,0	22,5	30	43,0	---	---									90	89,7	
CRT 65-160 E	3 x 380-400V	8,0	5,5	7,5	13,0	---	---											
CRT 65-160 D	3 x 380-400V	10,0	7,5	10	16,0	---	---											
CRT 65-160 C	3 x 380-400V	11,5	9,2	12,5	18,5	---	---											
CRT 65-160 B	3 x 380-400V	13,5	11,0	15	21,5	---	---											
CRT 65-160 A	3 x 380-400V	16,0	15,0	20	26,0	---	---											
CRT 65-200 C	3 x 380-400V	20,0	15,0	20	32,0	---	---											
CRT 65-200 B	3 x 380-400V	23,0	18,5	25	36,5	---	---											
CRT 65-200 A	3 x 380-400V	27,0	22,5	30	43,0	---	---											
CRT 65-250 B	3 x 380-400V	37,0	30,0	40	58,0	---	---											
CRT 65-250 A	3 x 380-400V	46,0	37,0	50	72,0	---	---											
CRT 80-160 D	3 x 380-400V	12,5	11,0	15	20,5	---	---											
CRT 80-160 C	3 x 380-400V	15,0	15,0	20	24,0	---	---											
CRT 80-160 B	3 x 380-400V	18,5	18,5	25	30,0	---	---											
CRT 80-160 A	3 x 380-400V	22,0	22,5	30	35,0	---	---											
CRT 80-200 B	3 x 380-400V	33,5	30,0	40	54,0	---	---											
CRT 80-200 A	3 x 380-400V	39,0	37,0	50	62,0	---	---											

PREVALENZA TOTALE in METRI COLONNA ACQUA / TOTAL PUMP HEAD AND WATER COLUMN HEIGHT IN m.

DATI IDRAULICI / HYDRAULIC DATA

m ³ /h	33	36	39	42	48	54	60	66	72	78	84	96	108	120	132	144	156	168	180	195	210	225	240	
l/min.	550	600	650	700	800	900	1000	1100	1200	1300	1400	1600	1800	2000	2200	2400	2600	2800	3000	3250	3500	3750	4000	
29	26																							
29	26																							
44,5	42,5																							
47,5	45,5																							
51	45																							
63,5	58																							
74	68,5																							
27	25,5	23	21																					
27	25,5	23	21																					
31	29,5	28	26	22																				
31	29,5	28	26	22																				
40,5	39,5	38,5	37	34,5	31,5																			
50	49	48	46,5	44	40,5																			
70	68,5	67	65,5	61,5	54																			
88	87	85,5	83,5	79,5	73																			
22,8	22	21,3	20,5	19	17	15	13	10																
22,8	22	21,3	20,5	19	17	15	13	10																
27,8	27,1	26,4	25,6	24	22,5	20,5	18	15,5																
27,8	27,1	26,4	25,6	24	22,5	20,5	18	15,5																
35,5	35	34,5	34	32	30,5	28,5	26	23,5	20,5															
38,5	38	37,5	37	35	33,5	31,5	29	26,5	23															
47,8	47,5	47	46,5	45	43,5	42	39,5	37	33															
51,7	51,2	50,7	50,2	49,2	48	46	43,5	41	38															
63	62,5	62	61,5	60,5	59,5	58	56,5	54,5	51,5															
70,5	70	69,5	68,5	67	65	63	61	58	54															
80	79,5	79	78,5	77	75	73	70,5	68	65															
89,3	89	88,5	88	86,5	85	83	81	79	71															
			24,5	24,2	24	23,5	23	22,5	21,5	20,5	18,5	16	12,5											
			28,5	28,2	28	27,5	27	26,5	25,8	25	23	21	18	14										
			32	31,7	31,5	31,2	30,7	30,2	29,7	29	27	25	22	19	16									
			35,5	35	34,8	34,5	34	33,5	33	32,5	31	29	26,5	24	20									
			40	39,5	39	38,5	38	37,5	37	36,5	35,5	33,5	31	28,5	26									
			48,5	48	47,5	47	46,2	45,5	44,5	42,5	40,5	38	34,5	31										
			52,5	52	51,5	51	50,5	50	49	47	45	43	40	36										
			60,5	60	59,5	59	58,5	58	57,5	56	54,5	52,5	49,5	45,5										
			79	78,5	78	77	76	75	74	72	69	66	63	58										
			89,5	89	88,5	87,5	86,5	85,5	84	82,5	80	77	74	70	66									
						27,5	27,4	27,3	27,1	26,4	25,2	24	22,5	21	19,2	17,4	15,5							
						30,6	30,5	30,4	30,2	29,6	28,7	27,5	26,2	24,8	23,2	21,5	19,6	17						
						35	34,9	34,8	34,6	34,1	33,4	32,5	31,3	30,2	28,7	27	25,3	22,8	20					
						38,6	38,5	38,2	38	37,7	37	36,3	35,3	34,2	33	31,6	30	27,8	25	22				
						54,1	54	53,8	53,6	53,1	52,2	51,3	50,4	49,2	47,7	46,2	44,2	41,2	38	33,6	28,5			
						58,8	58,7	58,5	58,3	57,8	57,2	56,3	55,4	54,2	53	51,5	50	48	45	42	39			

PREVALENZA TOTALE IN METRI COLONNA ACQUA / TOTAL PUMP HEAD AND WATER COLUMN HEIGHT IN M.

MODELLO MODEL	DIMENSIONI POMPA in mm / PUMP DIMENSIONS to mm														
	DNA	DNM	A	B	C	D	E	F	G	H	H1	H2	N	O	P
CRM 32-160 C	50	32	100	70	480	240	190	15	240	322	132	160	80	13,5	50
CRT 32-160 C	50	32	100	70	480	240	190	15	240	322	132	160	80	13,5	50
CRM 32-160 B	50	32	100	70	480	240	190	15	240	322	132	160	80	13,5	50
CRT 32-160 B	50	32	100	70	480	240	190	15	240	322	132	190	80	13,5	50
CRT 32-160 A	50	32	100	70	510	240	190	15	240	322	132	190	80	13,5	50
CRM 32-200 C	50	32	100	70	530	240	190	15	273	370	160	180	80	15	50
CRT 32-200 C	50	32	100	70	530	240	190	15	273	370	160	180	80	15	50
CRT 32-200 B	50	32	100	70	630	240	190	15	273	370	160	180	80	15	50
CRT 32-200 A	50	32	100	70	630	240	190	15	273	370	160	180	80	15	50
CRT 32-250 C	50	32	125	95	745	320	250	15	335	445	180	225	100	18	65
CRT 32-250 B	50	32	125	95	745	320	250	15	335	445	180	225	100	18	65
CRT 32-250 A	50	32	125	95	745	320	250	15	335	445	180	225	100	18	65
CRM 40-160 B	65	40	100	70	550	240	190	15	240	322	132	160	80	15	50
CRT 40-160 B	65	40	100	70	550	240	190	15	240	322	132	160	80	15	50
CRM 40-160 A	65	40	100	70	550	240	190	15	240	322	132	160	80	15	50
CRT 40-160 A	65	40	100	70	550	240	190	15	240	322	132	160	80	15	50
CRT 40-200 B	65	40	100	70	640	265	212	15	281	370	160	180	100	15	50
CRT 40-200 A	65	40	100	70	640	265	212	15	281	370	160	180	100	15	50
CRT 40-250 B	65	40	125	95	745	320	250	15	335	435	180	225	100	18	65
CRT 40-250 A	65	40	125	95	745	320	250	15	335	435	180	225	100	18	65
CRM 50-160 D	65	50	100	70	570	265	212	15	268	372	160	180	100	15	50
CRT 50-160 D	65	50	100	70	570	265	212	15	268	372	160	180	100	15	50
CRM 50-160 C	65	50	100	70	570	265	212	15	268	372	160	180	100	15	50
CRT 50-160 C	65	50	100	70	570	265	212	15	268	372	160	180	100	15	50
CRT 50-160 B	65	50	100	70	650	265	212	15	268	372	160	180	100	15	50
CRT 50-160 A	65	50	100	70	650	265	212	15	268	372	160	180	100	15	50
CRT 50-200 C	65	50	100	70	745	265	212	15	335	425	160	200	100	18	50
CRT 50-200 B	65	50	100	70	745	265	212	15	335	425	160	200	100	18	50
CRT 50-200 A	65	50	100	70	745	265	212	15	335	425	160	200	100	18	50
CRT 50-250 C	65	50	125	95	750	320	250	15	340	435	180	225	100	18	65
CRT 50-250 B	65	50	125	95	795	320	250	15	340	435	180	225	100	18	65
CRT 50-250 A	65	50	125	95	825	320	250	15	340	435	180	225	100	18	65
CRT 65-160 E	80	65	125	95	610	280	212	15	295	395	160	200	100	18	65
CRT 65-160 D	80	65	125	95	610	280	212	15	295	395	160	200	100	18	65
CRT 65-160 C	80	65	125	95	750	280	212	15	295	395	160	200	100	18	65
CRT 65-160 B	80	65	125	95	750	280	212	15	295	395	160	200	100	18	65
CRT 65-160 A	80	65	125	95	750	280	212	15	295	395	160	200	100	18	65
CRT 65-200 C	80	65	125	95	745	320	250	15	335	445	180	225	100	18	65
CRT 65-200 B	80	65	125	95	790	320	250	15	335	445	180	225	100	18	65
CRT 65-200 A	80	65	125	95	825	320	250	15	360	455	180	225	100	18	65
CRT 65-250 B	80	65	160	120	825	360	280	18	370	485	200	250	100	18	85
CRT 65-250 A	80	65	160	120	825	360	280	18	370	485	200	250	100	18	85
CRT 80-160 D	100	80	125	95	790	320	250	15	350	445	180	225	125	18	65
CRT 80-160 C	100	80	125	95	790	320	250	15	350	445	180	225	125	18	65
CRT 80-160 B	100	80	125	95	835	320	250	15	350	445	180	225	125	18	65
CRT 80-160 A	100	80	125	95	870	320	250	15	360	445	180	225	125	18	65
CRT 80-200 B	100	80	125	95	900	345	280	15	360	470	180	250	125	18	65
CRT 80-200 A	100	80	125	95	900	345	280	15	360	470	180	250	125	18	65

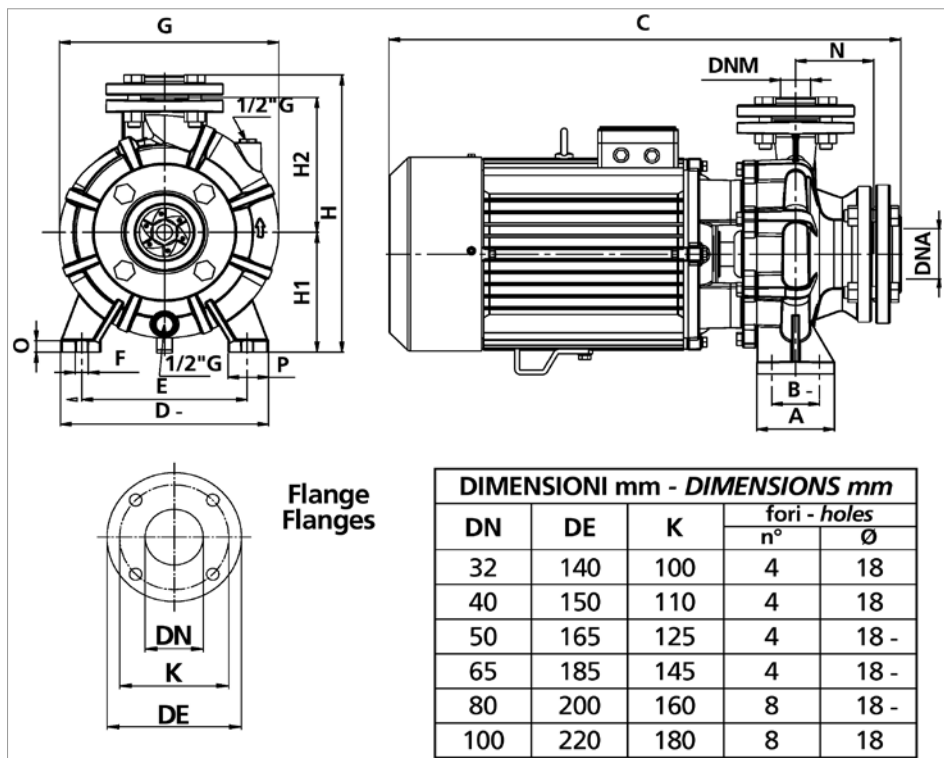
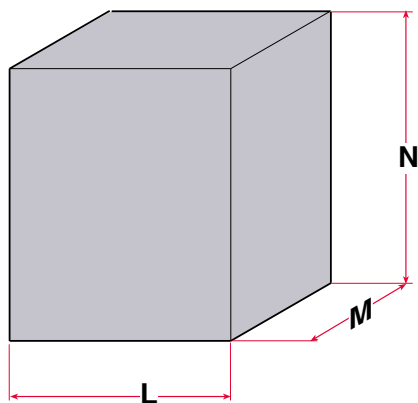

MODELLO MODEL	DIMENSIONI SCATOLA / PACKING DIMENSIONS			
	L mm	M mm	N mm	Peso / Weight Kg
CRM 32-160 C	250	520	360	36
CRT 32-160 C	250	520	360	36
CRM 32-160 B	250	520	360	39
CRT 32-160 B	250	520	360	39
CRT 32-160 A	250	520	360	42
CRM 32-200 C	300	660	390	52
CRT 32-200 C	300	660	390	52
CRT 32-200 B	300	660	390	63
CRT 32-200 A	300	660	390	69
CRT 32-250 C	355	790	455	83
CRT 32-250 B	355	790	455	90
CRT 32-250 A	355	790	455	120
CRM 40-160 B	250	560	370	47
CRT 40-160 B	250	560	370	47
CRM 40-160 A	250	560	370	50
CRT 40-160 A	250	560	370	50
CRT 40-200 B	300	660	390	65
CRT 40-200 A	300	660	390	71
CRT 40-250 B	355	790	455	91
CRT 40-250 A	355	790	455	121
CRM 50-160 D	300	660	390	50
CRT 50-160 D	300	660	390	50
CRM 50-160 C	300	660	390	60
CRT 50-160 C	300	660	390	60
CRT 50-160 B	300	660	390	65
CRT 50-160 A	300	660	390	71

MODELLO MODEL	DIMENSIONI SCATOLA / PACKING DIMENSIONS			
	L mm	M mm	N mm	Peso / Weight Kg
CRT 50-200 C	355	790	455	82
CRT 50-200 B	355	790	455	89
CRT 50-200 A	355	790	455	122
CRT 50-250 C	355	790	455	125
CRT 50-250 B	355	790	455	140
CRT 50-250 A	380	850	465	149
CRT 65-160 E	355	790	455	70
CRT 65-160 D	355	790	455	80
CRT 65-160 C	355	790	455	84
CRT 65-160 B	355	790	455	90
CRT 65-160 A	355	790	455	120
CRT 65-200 C	355	790	455	122
CRT 65-200 B	355	790	455	138
CRT 65-200 A	380	850	465	148
CRT 65-250 B	380	920	485	235
CRT 65-250 A	380	920	485	250
CRT 80-160 D	380	850	465	99
CRT 80-160 C	380	850	465	129
CRT 80-160 B	380	850	465	143
CRT 80-160 A	380	920	485	152
CRT 80-200 B	380	920	485	233
CRT 80-200 A	380	920	485	247

PS 2 - PD 2 - PI 2 RB



GRUPPI DI PRESSURIZZAZIONE CON POMPE BIGIRANTI (PS 2 - RB)
PRESSURE SYSTEM WITH TWO IMPELLERS CENTRIFUGAL PUMPS (PS 2 - RB)

1

MODELLO MODEL	POTENZA/POWER		PHASE	DNA	DNM	Q max l/min	Q max l/min
	P2(Kw)	HP					
PS2 - RB 150M							
PS2 - RB 200M							
PS2 - RB 150T							
PS2 - RB 200T							
PS2 - RB 300T							
PS2 - RB 400T							

GRUPPI DI PRESSURIZZAZIONE CON PRESSOSTATI DIGITALI (PD 2 - RB)
PRESSURE SYSTEM WITH N°2 DIGITAL PRESSURE SWITCH (PD 2 - RB)

2

MODELLO MODEL	POTENZA/POWER		PHASE	DNA	DNM	Q max l/min	Q max l/min
	P2(Kw)	HP					
PD2 - RB 150M	1,1 + 1,1	1,5 + 1,5	1-PHASE	2"	1"1/2	300	52
PD2 - RB 200M	1,5 + 1,5	2 + 2	1-PHASE	2"	1"1/2	350	58

GRUPPI DI PRESSURIZZAZIONE CON INVERTER (PI 2 - RB)
PRESSURE SYSTEM WITH INVERTER (PI 2 - RB)

3

MODELLO MODEL	POTENZA/POWER		PHASE	DNA	DNM	Q max l/min	Q max l/min
	P2(Kw)	HP					
PI2 - RB 150M	1,1 + 1,1	1,5 + 1,5	1-PHASE	2"	1"1/2	300	52
PI2 - RB 200M	1,5 + 1,5	2 + 2	1-PHASE	2"	1"1/2	350	58
PI2 - RB 150T	1,1 + 1,1	1,5 + 1,5	3-PHASE	2"	1"1/2	300	52
PI2 - RB 200T	1,5 + 1,5	2 + 2	3-PHASE	2"	1"1/2	350	58
PI2 - RB 300T	2,2 + 2,2	3 + 3	3-PHASE	2"	1"1/2	350	66
PI2 - RB 400T	3,0 + 3,0	4 + 4	3-PHASE	2" 1/2	2"	400	70
PI2 - RB 550T	4,0 + 4,0	5,5 + 5,5	3-PHASE	2" 1/2	2"	400	70
PI2 - RB 750T	5,5 + 5,5	7,5 + 7,5	3-PHASE	2" 1/2	2"	600	100

PS 2 - PD 2 - PI 2 RM



1



2



3

GRUPPI DI PRESSURIZZAZIONE CON POMPE MULTISTADIO (PS 2 - RM) PRESSURE SYSTEM WITH CENTRIFUGAL MULTISTAGE ELECTRIC PUMPS (PS 2 - RM)

1	MODELLO MODEL	POTENZA/POWER		PHASE	DNA	DNM	Q max l/min	Q max l/min
		P2(Kw)	HP					
	PS2 - RM 100M	0,75 + 0,75	1 + 1	1-PHASE	1"1/2	1"1/2	180	45
	PS2 - RM 150M	1,1 + 1,1	1,5 + 1,5	1-PHASE	1"1/2	1"1/2	180	60

GRUPPI DI PRESSURIZZAZIONE CON 2 PRESSOSTATI DIGITALI (PD 2 - RM) PRESSURE SYSTEM WITH N°2 DIGITAL PRESSURE SWITCH (PD 2 - RM)

2	MODELLO MODEL	POTENZA/POWER		PHASE	DNA	DNM	Q max l/min	Q max l/min
		P2(Kw)	HP					
	PD2 - RM 100M	0,75 + 0,75	1 + 1	1-PHASE	1"1/2	1"1/2	180	45
	PD2 - RM 150M	1,1 + 1,1	1,5 + 1,5	1-PHASE	1"1/2	1"1/2	180	60

GRUPPI DI PRESSURIZZAZIONE CON INVERTER CON POMPE MULTISTADIO (PS 2 - RM) PRESSURE SYSTEM WITH INVERTER WITH CENTRIFUGAL MULTISTAGE ELECTRIC PUMPS (PS 2 - RM)

3	MODELLO MODEL	POTENZA/POWER		PHASE	DNA	DNM	Q max l/min	Q max l/min
		P2(Kw)	HP					
	PI2 - RM 100M	0,75 + 0,75	1 + 1	1-PHASE	1"1/2	1"1/2	180	45
	PI2 - RM 150M	1,1 + 1,1	1,5 + 1,5	1-PHASE	1"1/2	1"1/2	180	60
	PI2 - RM 150T	3,0 + 3,0	4 + 4	3-PHASE	1"1/2	1"1/2	180	60

GMA 0225



MISCELA 5%
MISCELA 5%

APPLICAZIONI

Motopompa autodescante portatile, particolarmente adatta per l'approvvigionamento e la distribuzione di acque pulite e chiare in agricoltura ed in giardino dove non è possibile un collegamento elettrico.

Motore a scoppio 2 tempi.

APPLICATION

Selfpriming hand-carry motor pumps. Particularly suitable to supply and distribute clean water for agricultural and germaning purposes, when an electrical connection is not possible.

2-stroke engine.

MODELLO MODEL	Aspirazione mandata Suction delivery	Giri/min r.p.m.	Portata max Delivery max. (l/')	Prevalenza max. Head max. (mt)	Altezza aspirazione Suction depth (mt)	Potenza motore Motor power (HP)	Capacità serbatoio Tank Capacity (lt)	Avviamento Start system	Dimensioni Dimensions (mm)	Peso Weight (Ka)
GMA0225	25 (1")	6500	130	22	7	1,5	1	manu: reco		

GMA 0425

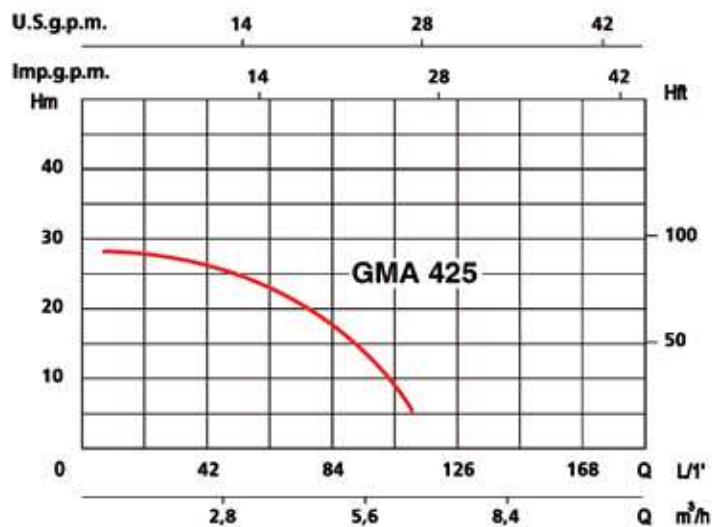

APPLICAZIONI

Motopompa autodescendente portatile, particolarmente adatta per l'approvvigionamento e la distribuzione di acque pulite e chiare in agricoltura ed in giardino dove non è possibile un collegamento elettrico.

Motore a scoppio 4 tempi.

APPLICATION

Selfpriming hand-carry motor pumps. Particularly suitable to supply and distribute clean water for agricultural and germinating purposes, when an electrical connection is not possible.

4-stroke engine.

MODELLO MODEL	Aspirazione mandata Suction delivery	Giri/min r.p.m.	Portata max Delivery max. (l/1')	Prevalenza max. Head max. (mt)	Altezza aspirazione Suction depth (mt)	Potenza motore Motor power (HP)	Capacità serbatoio Tank Capacity (lt)	Avviamento Start system	Dimensioni Dimensions (mm)	Peso Weight (Ka)
GMA0425	25 (1")	6500	110	28	7	1,5	1	manual recoil		

GMA 0430

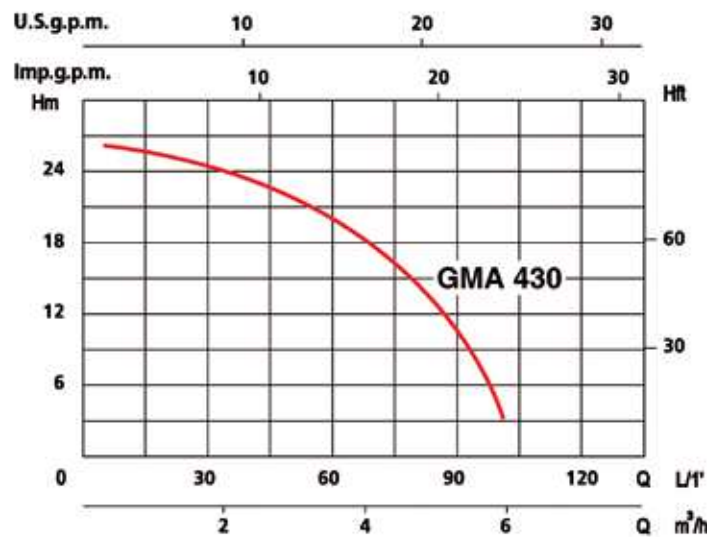

APPLICAZIONI

Motopompa autodescendente portatile, particolarmente adatta per l'approvvigionamento e la distribuzione di acque pulite e chiare in agricoltura ed in giardino dove non è possibile un collegamento elettrico.

Motore a scoppio 2 tempi.

APPLICATION

Selfpriming hand-carry motor pumps. Particularly suitable to supply and distribute clean water for agricultural and germaning purposes, when an electrical connection is not possible.

2-stroke engine.

MODELLO MODEL	Aspirazione mandata Suction delivery	Giri/min r.p.m.	Portata max Delivery max. (l/1')	Prevalenza max. Head max. (mt)	Altezza aspirazione Suction depth (mt)	Potenza motore Motor power (HP)	Capacità serbatoio Tank Capacity (lt)	Avviamento Start system	Dimensioni Dimensions (mm)	Peso Weight (Kg)
GMA0430	25 (1")	3600	100	26	7	2,5	1	manu: reco		

GMA 0440

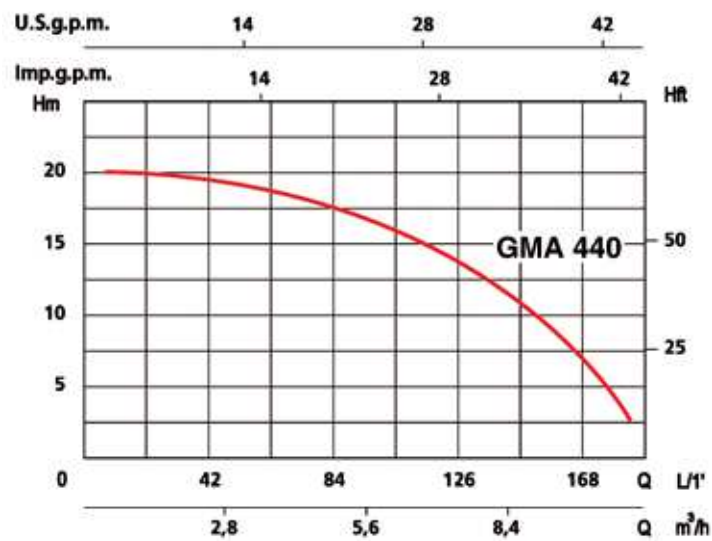

APPLICAZIONI

Motopompa autodescendente portatile, particolarmente adatta per l'approvvigionamento e la distribuzione di acque pulite e chiare in agricoltura ed in giardino dove non è possibile un collegamento elettrico.

Motore a scoppio 4 tempi.

APPLICATION

Selfpriming hand-carry motor pumps. Particularly suitable to supply and distribute clean water for agricultural and gardening purposes, when an electrical connection is not possible.

4-stroke engine.

MODELLO MODEL	Aspirazione mandata Suction delivery	Giri/min r.p.m.	Portata max Delivery max. (l/h)	Prevalenza max. Head max. (mt)	Altezza aspirazione Suction depth (mt)	Potenza motore Motor power (HP)	Capacità serbatoio Tank Capacity (lt)	Avviamento Start system	Dimensioni Dimensions (mm)	Peso Weight (Kg)
GMA0440	40(1" 1/2)	3600	180	20	7	2,5	1	manual recoil		

K



APPLICAZIONI

- Queste pompe sono idonee per il maneggio di liquidi chiari e leggeri, come ad esempio l'acqua, la benzina, il diesel e tutti i carburanti, il petrolio combustibile, l'alcohol, soluzioni chimiche leggere, l'olio da cucina, ecc., e sono le uniche pompe a mano sicure per il maneggio di liquidi bollenti - fino a una temperatura di 80° C (176° F).

APPLICATIONS

- *These pumps are suitable for the handling of clear and light liquids such as water, petrol, diesel and all fuels, paraffin, alcohol, light chemical solutions, edible oils etc. and are the only hand pumps safe for use with very hot liquids - up to 80°C (176°F)*

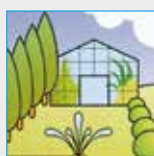

ARVEN[®]
WATER ■ PUMPS

Funzionamento:

Le pompe vengono messe in funzione dal movimento di una manovella, che causa la rotazione a semicerchio dentro la pompa, dell'asse e del pistone alato, equipaggiato di valvole a cerniera. Inoltre, racchiuso nel rivestimento della pompa c'è il divisore (o distributore) di aspirazione, equipaggiato di linguette. La tenuta a baderna, compressa dall'anello e dal dado, agisce come chiusura ermetica tra l'asse e il rivestimento della pompa. Il modello standard ha le flange filettate ed è provvisto pure di controflange filettate.

Caratteristiche costruttive:

- Corpo: in ghisa
- Parti interne: in ottone
- Manovella: in acciaio
- Tenuta a baderna: in corda di grafite morbida

- il corpo interno affusolato - questo vantaggio tecnologico, unico della pompa K, assicura il posizionamento automatico delle pale nel corpo e garantisce un funzionamento efficiente e senza problemi anche dopo anni di uso;
- un tappo antigelo - permette all'acqua di essere scaricata se c'è rischio di gelo;
- controllo completo di qualità - ogni pompa vienemessa alla prova individualmente con un'altezza d'aspirazione di 7 metri di acqua e un'altezza di mandata di 20 metri.

Operation of the pump:

The pumps are operated by the movement of the handle wich causes the shaft and the wing piston, fitted with flap valves, to semi-rotate within the pump. Also enclosed in the body of the pump is the suction divider, fitted with flaps. Gland packing compressed by the gland ring and nut acts as a seal between the shaft and the pump cover. The standard model has threaded flanges and is supplied with threaded counter flanges. Two lugs facilitate the mounting of the pump to a wall or similar structure.

Features:

- Casing: Cast iron
- Internals: Brass
- Shaft: Steel
- Gland Packing: Soft graphite cord

- The tapered internal body - this unique technological advantage assures automatic settlement of the wings in the body and guarantees smooth efficient operation aven after years of usage
- A frost plug - allows water to be drained if there is a risk of frost
- Thorough quality control - each pump is individually tested to a suction lift of 7 m of water and 20 m of delivery head.

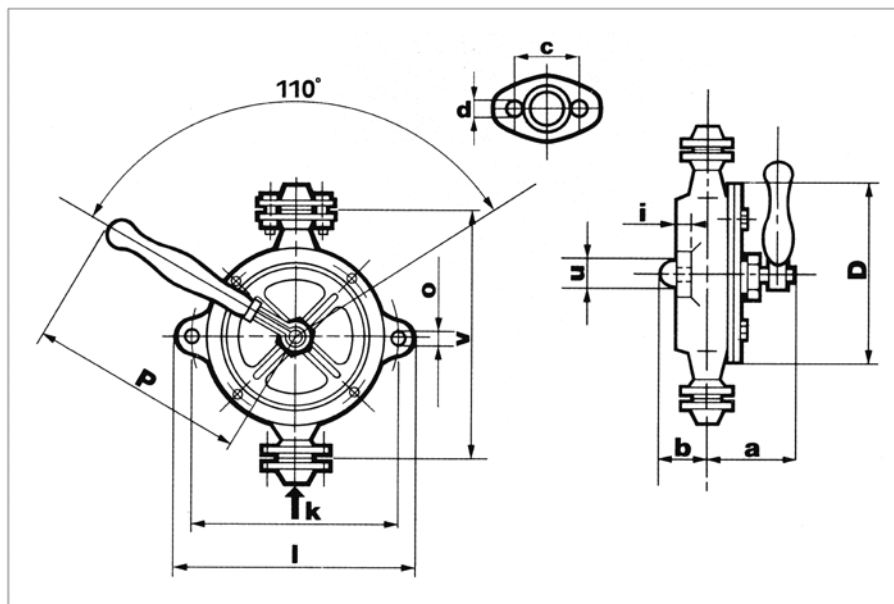

Tipo Type	Dimensioni mm Dimensions mm													
	DNM DNA	a	b	c	d	i	k	l	o	P	u	v	D	KG
KPM 0300	1/2"	140	55	55	9,5	10	130	160	13	300	25	175	135	4
KPM 0400	3/4"	140	55	65	9,5	10	150	180	13	300	25	205	150	6
KPM 0500	1"	145	60	75	9,5	10	170	200	13	360	30	230	170	8
KPM 0600	1. 1/4"	170	62	90	14	12	200	240	13	450	30	275	200	10

TIPO TYPE	DIAMETRO TUBI CASING INNER SIMENSIONS		PORTATA DEBIT	PREVALENZA HEAD	ASPIRAZIONE MAX MAX. DEPTH OF WELL
KPM0300	1/2"	14	11,50	25	7 mt
KPM0400	3/4"	19	17,25	25	7 mt
KPM0500	1"	25	22,50	25	7 mt
KPM0600	1"1/4	32	29	22	7 mt

NP

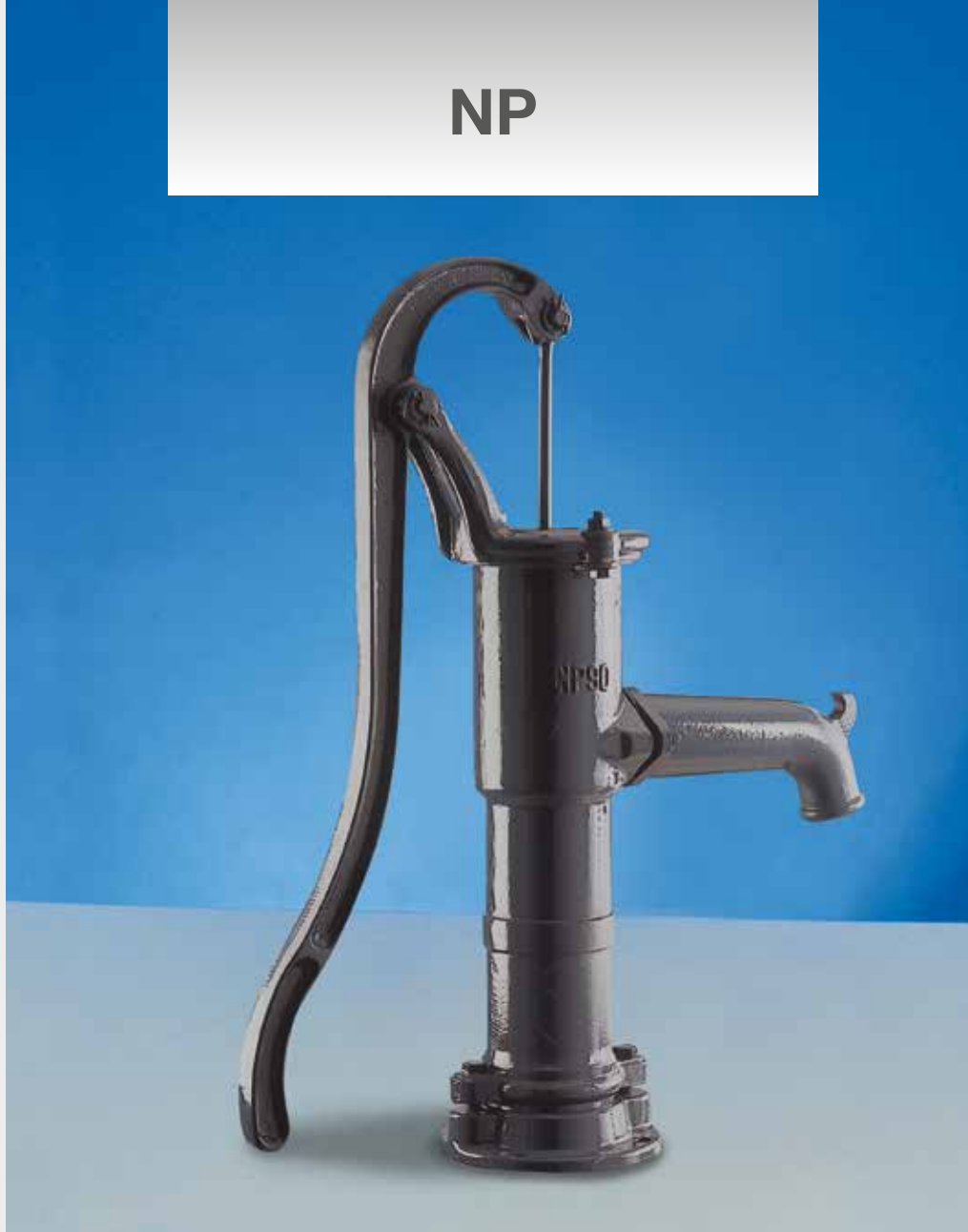

APPLICAZIONI

• Le pompe ad azionamento manuale del tipo NP sono utilizzate principalmente per pozzi freatici, perforati e scavati con una profondità non superiore a 7 metri. Costituiscono il tipo più piccolo ed economico di pompe per pozzi domestici. La pompa NP viene utilizzata in ambiente domestico per pompare acqua potabile da bere o sanitaria priva di solidi sospesi duri, con una temperatura non superiore a 40°C. Si raccomanda di usare le pompe in luoghi in cui non vi sia pericolo che l'acqua geli nel corpo, per es. in un corridoio o in una cantina. Se la pompa è installata all'aperto, è necessario smontarla per l'inverno o proteggerla perfettamente contro il gelo.

APPLICATIONS

• The NP pump is used in households for pumping drinking or service water without hard suspended solids, of a temperature of not more than 40°C. It is recommended to use the pumps in such localities where there is no danger of the water freezing in the casing, e.g. in a corridor or in a cellar. If the pump is installed out-of-door, it is necessary to dismount it for the winter or to protect it perfectly against freezing.

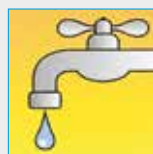

ARVEN[®]
WATER ■ PUMPS

APPLICAZIONI

• Le pompe ad azionamento manuale del tipo NP sono utilizzate principalmente per pozzi freatici, perforati e scavati con una profondità non superiore a 7 metri. Costituiscono il tipo più piccolo ed economico di pompe per pozzi domestici. La pompa NP viene utilizzata in ambiente domestico per pompare acqua potabile da bere o sanitaria priva di solidi sospesi duri, con una temperatura non superiore a 40°C. Si raccomanda di usare le pompe in luoghi in cui non vi sia pericolo che l'acqua geli nel corpo, per es. in un corridoio o in una cantina. Se la pompa è installata all'aperto, è necessario smontarla per l'inverno o proteggerla perfettamente contro il gelo.

APPLICATIONS

• The NP pump is used in households for pumping drinking or service water without hard suspended solids, of a temperature of not more than 40°C. It is recommended to use the pumps in such localities where there is no danger of the water freezing in the casing, e.g. in a corridor or in a cellar. If the pump is installed out-of-door, it is necessary to dismount it for the winter or to protect it perfectly against freezing.

Tipo Type	Dimensioni mm Dimensions mm						
	A	B	D	d1	E	F	L
NP	674	520	75	1.1/4"	237	295	160

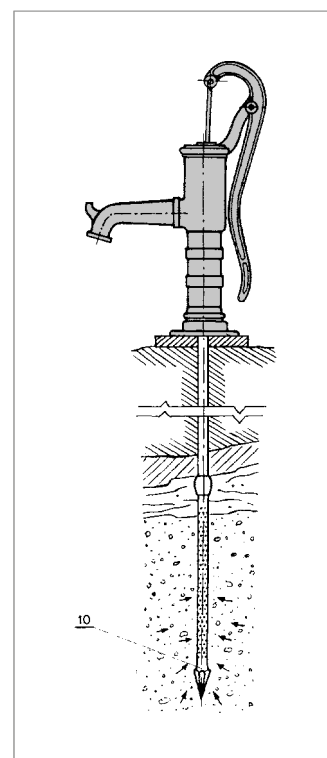
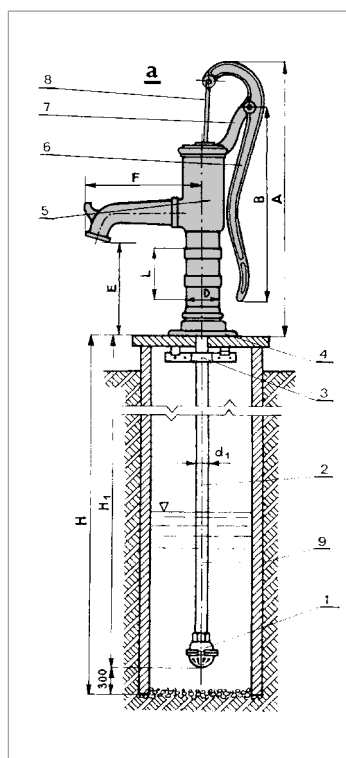

TIPO TYPE	DIAMETRO TUBI CASING INNER DIMENSIONS		PORTATA DEBIT	PREVALENZA HEAD	ASPIRAZIONE MAX MAXIMUM DEPTH OF WELL	PESO WEIGHT
NPM0600 CON ZANCHE A MURO	1.1/4"	32 mm	28 L/min.	30	7 mt	17 Kg
NPM0650 CON BASE	1.1/4"	32 mm	28 L/min.	30	7 mt	17 Kg

ACCESSORI - ACCESSORIES



GALLEGGIANTE FLOATER

CODICE / CODE		MISURA SIZE
H07RN-F	PVC	
0786.TECNH02.00	0786.TECNO02.00	2 MT
0786.TECNH03.00	0786.TECNO03.00	3 MT
0786.TECNH05.00	0786.TECNO05.00	5 MT
0786.TECNH10.00	0786.TECNO10.00	10 MT

- H07RN-F: SVUOTAMENTO - EMPTYING
- PVC: SVUOTAMENTO E RIEMPIMENTO / EMPTYING AND FILLING



QUADRO ELETTRICO MONOFASE PER ELETTROPOMPE SOMMERSIBILI SINGLE-PHASE CONTROL BOARD FOR SUBMERSIBLE ELECTRIC PUMPS

CODICE CODE	POTENZA MOTORE POWER		CONDENSATORE 450 V x µF
	kW	Hp	
0724.KNG1500.00	1,1	1,5	40
0724.KNG2000.00	1,5	2	50
0724.KNG3000.00	2,2	3	80

COMPONENTI	COMPONENTS
<ul style="list-style-type: none"> • CASSETTA IN PLASTICA • RELÉ PER COMANDO GALLEGGIANTE • CONDENSATORE • INTERRUTTORE AUTOMATICO/MANUALE • PROIETTORE TERMICO CON RIARMO MANUALE • CLASSE DI PROTEZIONE IP54 	<ul style="list-style-type: none"> • PLASTIC BOX • FLOATING CONTROL RELAY • CAPACITOR • ON/OFF SWITCH • THERMIC PROTECTOR - MANUAL RESET • IP55 INSULATION CLASS



QUADRO ELETTRICO TRIFASE PER ELETTROPOMPE SOMMERSIBILI THREE-PHASE CONTROL BOARD FOR SUBMERSIBLE ELECTRIC PUMPS

CODICE CODE	POTENZA MOTORE POWER		A	Volt
	kW	Hp		
0726.KTC6000.00	1,1 ÷ 4,5	1,5 ÷ 6	1 ÷ 20	400

COMPONENTI	COMPONENTS
<ul style="list-style-type: none"> • CASSETTA IN PLASTICA ISOLANTE COMPLETA DI TELERUTTORE • COMMUTATORE MANUALE/AUTOMATICO • PULSANTE DI RELÉ TERMICO • SPINA A 3 POLI + N + T • CLASSE DI PROTEZIONE IP54 • FUSIBILI GENERALI • TRASFORMATORI AMPEROMETRICI • INTERRUTTORE DI MANOVRA - SEZIONATORE BLOCCAPORTA 	<ul style="list-style-type: none"> • PLASTIC BOX • REMOTE CONTROL SWITCH • ON / OFF SWITCH • THERMIC PROTECTOR • MANUAL RESET • 3 POLES + N + T PLUG • IP55 INSULATION CLASS • GENERAL FUSES • AMMETER TRANSFORMER • WORKING SWITCH - DOOR-LOCKING SWITCH

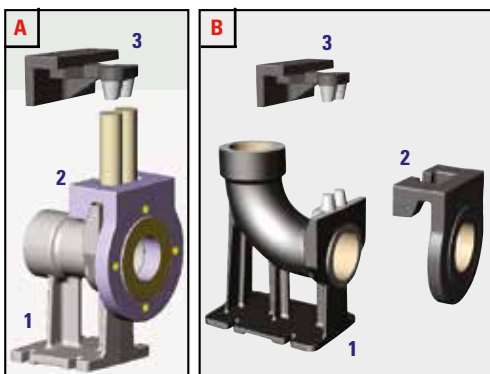

CODICE CODE	MISURA SIZE
0317.TGF1000.00	A - Kit scivolo di discesa a 2 tubi guida (DN 50) completo di: Kit guide rail complete of:
0317.TGF1001.00 0317.TGF1002.00 0317.TGF1003.00	1 - Base / Base 2 - Aggancio flangiato / Flange coupling 3 - Supporto tubi di discesa / Pipe support
0317.TGF2000.00	B - Kit scivolo di discesa a 2 tubi guida (DN 80) completo di: Kit guide rail complete of:
0317.TGF3000.00 0317.TGF4000.00 0317.TGF6000.00	1 - Base / Base 2 - Aggancio flangiato / Flange coupling 3 - Supporto tubi di discesa / Pipe support

ACCESSORI - ACCESSORIES



VALVOLA DI RITEGNO IN ACCIAIO INOX (AISI 304)

CHECK VALVE IN STAINLESS STEEL (AISI 304)

CODICE CODE	MISURA SIZE	MATERIALE MATERIAL
ADF.063.03/M	1/2"	AISI 304 FPM
ADF.063.04/M	3/4"	
ADF.063.05/M	1"	
ADF.063.06/M	1 1/4"	
ADF.063.07/M	1 1/2"	
ADF.063.08/M	2"	



VALVOLA DI RITEGNO IN ACCIAIO INOX (AISI 304) COMPLETA DI FILTRO

CHECK VALVE IN STAINLESS STEEL (AISI 304) COMPLETE WITH FILTER

CODICE CODE	MISURA SIZE	MATERIALE MATERIAL
ADF.064.03/M	1/2"	AISI 304 FPM
ADF.064.04/M	3/4"	
ADF.064.05/M	1"	
ADF.064.06/M	1 1/4"	
ADF.064.07/M	1 1/2"	
ADF.064.08/M	2"	



RACCORDO SIMMETRICO RAPIDO CON FILETTATURA MASCHIO

ADAPTERS WITH MALE THREAD

CODICE CODE	MISURA SIZE	MATERIALE MATERIAL
0663.KTC1500.00	1 1/2"	ALLUMINIO ALUMINUM
0663.KTC2000.00	2"	
0663.KTC4000.00	3"	



RACCORDO SIMMETRICO RAPIDO CON PORTAGOMMA

SUCTION HOSE COUPLING

CODICE CODE	MISURA SIZE	MATERIALE MATERIAL
0662.KTC1500.00	1 1/2"	ALLUMINIO ALUMINUM
0662.KTC2000.00	2"	
0662.KTC4000.00	3"	



ADF.205

ADF.225

RACCORDO PORTAGOMMA IN OTTONE

THREE PIECES HOSE CONNECTOR BRASS

CODICE CODE	MISURA SIZE
ADF.205.04 X20	RACCORDO PORTAGOMMA 3PZ DIRITTO 3/4" x 20 HOSE CONNECTOR STRAIGHT 3 PCS 3/4" x 20
ADF.205.04 X25	RACCORDO PORTAGOMMA 3PZ DIRITTO 3/4" x 25 HOSE CONNECTOR STRAIGHT 3 PCS 3/4" x 25
ADF.205.05 X25	RACCORDO PORTAGOMMA 3PZ DIRITTO 1" x 25 HOSE CONNECTOR STRAIGHT 3 PCS 1" x 25
ADF.205.05 X30	RACCORDO PORTAGOMMA 3PZ DIRITTO 1" x 30 HOSE CONNECTOR STRAIGHT 3 PCS 1" x 30
ADF.205.07 X40	RACCORDO PORTAGOMMA 3PZ DIRITTO 1" 1/2 x 40 HOSE CONNECTOR STRAIGHT 3 PCS 1" 1/2 x 40
ADF.225.05 X25	RACCORDO PORTAGOMMA 3PZ CURVO 1" x 25 HOSE CONNECTOR STRAIGHT 3 PCS 1" x 25

ACCESSORI - ACCESSORIES



VALVOLA DI FONDO IN OTTONE
CHECK VALVE IN BRASS

CODICE CODE	MISURA SIZE
ADF.010.03	1/2"
ADF.010.04	3/4"
ADF.010.05	1"
ADF.010.06	1 1/4"
ADF.010.07	1 1/2"
ADF.010.08	2"



VALVOLA DI RITEGNO IN OTTONE
CHECK VALVE IN BRASS

CODICE CODE	MISURA SIZE
ADF.005.03	1/2"
ADF.005.04	3/4"
ADF.005.05	1"
ADF.005.06	1 1/4"
ADF.005.07	1 1/2"
ADF.005.08	2"

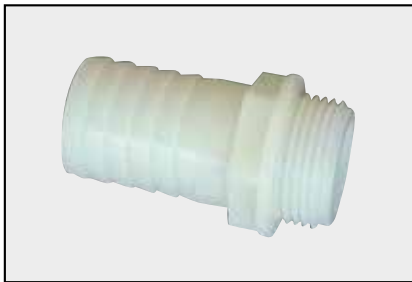

RACCORDO PORTAGOMMA DRITTO FILETTATO IN POLIAMMIDE (PA-NYLON)
STRAIGHT HOSE NOZZLE THREADED (PA-NYLON)

CODICE CODE	MISURA SIZE	CONFEZIONE PACKAGE
0361.RLG0300.00	1"	10 PEZZI
0361.MZR0300.00	1 1/4"	10 PEZZI
0371.ALK0800.00	1 1/2"	5 PEZZI
0371.SKP1000.00	2"	5 PEZZI



RACCORDO PORTAGOMMA CURVO MASCHIO (P.P)
ELBOW HOSE NOZZLE (P.P)

CODICE CODE	MISURA SIZE	CONFEZIONE PACKAGE
0371.AVX0800.00	1 1/2 (DN40)	5 PEZZI
0371.AVX1000.00	2" (DN50)	5 PEZZI



KIT D'ASPIRAZIONE 1"
1" SUCTION KIT

CODICE CODE	MISURA SIZE
/KIT.ASPIRAZ.00	TUBO 4MT CON VALVOLA DI FONDO/ 4MT HOSE WITH FOOT VALVE

ACCESSORI - ACCESSORIES



REGOLATORE DI PRESSIONE PER ELETTROPOMPE CON MANOMETRO
PRESSURE REGULATOR FOR ELECTRIC PUMPS WITH MANOMETER

CODICE CODE	TENS. DI ALIMENTAZ. INPUT VOLTAGE	INTENSITA' MAX INTENSITY MAX	INDICE DI PROT. PROTECTION RATING
0789.PRESC2C.00	220-240 v	10A	IP 65
	PRESSIONE MAX DI ESERCIZIO MAXIMUM WORKING PRESSURE	TEMP. MAX DI ESERCIZIO MAXIMUM TEMP. PRESSURE	ATTACCO (MASCHIO) CONNECTION (MALE)
	10 bar	35°C	1"

PRESSIONE DI PARTENZA REGOLABILE DA 1,5 A 2,5 BAR - ADJUSTABLE START PRESSURE FROM 1,5 UP 2,5 BAR



REGOLATORE DI PRESSIONE PER ELETTROPOMPE CON MANOMETRO (COMPLETO DI MICRO ACCUMULO)
PRESSURE REGULATOR FOR ELECTRIC PUMPS WITH MANOMETER (COMPLETE WITH SMALL STORAGE)

CODICE CODE	TENS. DI ALIMENTAZ. INPUT VOLTAGE	INTENSITA' MAX INTENSITY MAX	INDICE DI PROT. PROTECTION RATING
0789.PRESC2P.00	220-240 v	10A	IP 65
	PRESSIONE MAX DI ESERCIZIO MAXIMUM WORKING PRESSURE	TEMP. MAX DI ESERCIZIO MAXIMUM TEMP. PRESSURE	ATTACCO (MASCHIO) CONNECTION (MALE)
	10 bar	35°C	1"



REGOLATORE DI PRESSIONE PER ELETTROPOMPE CON MANOMETRO
PRESSURE REGULATOR FOR ELECTRIC PUMPS WITH MANOMETER

CODICE CODE	TENS. DI ALIMENTAZ. INPUT VOLTAGE	INTENSITA' MAX INTENSITY MAX	INDICE DI PROT. PROTECTION RATING
0789.PRESORM.00	220-240 v - 50/60 Hz	16 (8) A - 2 HP	IP 65
	PRESSIONE MAX DI ESERCIZIO MAXIMUM WORKING PRESSURE	TEMP. MAX DI ESERCIZIO MAXIMUM TEMP. PRESSURE	ATTACCO (MASCHIO) CONNECTION (MALE)
	10 bar	0÷60°C	1"

PRESSIONE DI PARTENZA REGOLABILE DA 1,5 A 3 BAR - ADJUSTABLE START PRESSURE FROM 1,5 UP 3 BAR

SET IDROSFERA 24 LITRI
24 LITERS TANK GROUP



CODICE CODE	COMPONENTI COMPONENTS
0718 JXT0710.00	<ul style="list-style-type: none"> SERBATOIO 24 LT VERTICALE - VERTICAL TANK 24 LT MANOMETRO SCALA 0÷6 BAR - PRESSURE GAUGE RACCORDO OTTONE 5 VIE - 5 WAYS CONNECTOR PRESSOSTATO - PRESSURE SWITCH
CLI-MONJTX0710	Kit assemblato su elettropompa / Kit mounted on a pump

IDROSFERA 24 LITRI A MEMBRANA
24 LITERS MEMBRANE PRESSURE TANK



CODICE CODE	PRESSIONE MAX MAX PRESSURE	CAPACITA' LITRI CAPACITY LITERS	RACCORDO CONNECTOR
0212.JTL1000.00	8 bar	24	1"

IDROSFERA ORIZZONTALE 20 LITRI
20 LITERS ORIZZONTAL PRESSURE TANK



CODICE CODE	PRESSIONE MAX MAX PRESSURE	CAPACITA' LITRI CAPACITY LITERS	RACCORDO CONNECTOR
0212.JTL1005.00	8 bar	20	1"

ACCESSORI - ACCESSORIES

SET IDROSFERA ORIZZONTALE LT 20 20 LITERS HORIZONTAL TANK GROUP



CODICE CODE	COMPONENTI COMPONENTS
0718.JTL1005.00	<ul style="list-style-type: none"> SERBATOIO 20 LT ORIZZONTALE - <i>ORIZZONTAL TANK 22 LT</i> MANOMETRO SCALA 0÷6 BAR - <i>PRESSURE GAUGE</i> RACCORDO OTTONE 5 VIE - <i>5 WAYS CONNECTOR</i> PRESSOSTATO - <i>PRESSURE SWITCH</i> TUBO FLESSIBILE - <i>FLEXIBLE HOSE</i>
CLI-MONJTL1005	Kit assemblato su elettropompa / Kit mounted on a pump



PRESSOSTATO - PRESSIONE DI PARTENZA REGOLABILI PRESSURE SWITCH - ADJUSTABLE START PRESSURE

CODICE CODE	BAR	Tensione alimentazione - <i>Power supply voltage</i>	1~115-230V (multiV)
0789.SWITCH1.00	0,5 ÷ 0,7	Frequenza - <i>Frequency</i>	50/60 Hz
		Intensità massima - <i>Max. current</i>	16 A
		Potenza massima della pompa - <i>Starting pressure range (cut-in)</i>	2,2 kW (3 hp)
		Pressione di avviamento - <i>Starting pressure range (cut-in)</i>	0,5 ÷ 7 bar
		Range d'arresto - <i>Stop pressure range (cut-out)</i>	1 ÷ 8 bar
		Differenziale massimo - <i>Maximum differential</i>	7,5 bar
		Differenziale minimo (regolabile) - <i>Minimum differential</i>	0,5 ÷ 1,5 bar
		Taratura di fabbrica - <i>Factory setting (cut-in/cut out)</i>	3/4 bar
		Classe di protezione - <i>Protection degree</i>	IP55
		Temperatura acqua - <i>Max water temperature</i>	40°C
Temperatura ambiente - <i>Net weight (without cables)</i>	50°C		
Connessione alla rete idrica - <i>Inlet thread</i>	G 1/4" F		



PRESSOSTATO PRESSURE SWITCH

CODICE CODE	TARATURA CALIBRATION BAR	PRODUTTORE / HANDFACTURER TIPO / TYPE
0790.RMC1000.00	1,4 ÷ 2,8	SQUARE D - FSG 2
0790.RMC2000.00	2,8 ÷ 7	SQUARE D - FYG 22
0790.RMC3000.00	5,6 ÷ 10,5	SQUARE D - FYG 32
0790.XMPA06B.00	0 ÷ 6	TELEMACANIQUE XMPA 06
0790.XMPA12B.00	1,3 ÷ 12	TELEMACANIQUE XMPA 12

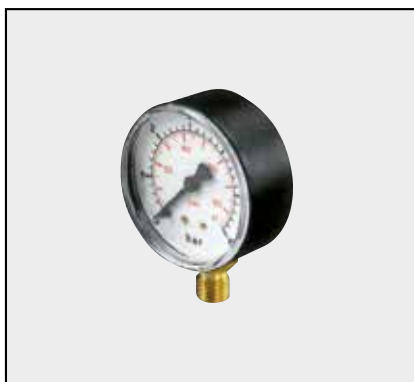

MANOMETRO PRESSURE GAUGE

CODICE CODE	ATTACCO CONNECTION	DIAMETRO DIAMETER	SCALA SCALE
0667.JTL1000.00	1" 1,4 RADIALE / <i>RADIAL</i>	50 mm	0 ÷ 6 BAR
0667.JTL12RA.CO	1" 1,4 RADIALE / <i>RADIAL</i>	63 mm	0 ÷ 12 BAR
0667.JTL12CO.00	1" 1,4 COASSIALE / <i>COAXIAL</i>	63 mm	0 ÷ 12 BAR



TUBO FLESSIBILE COMPLETO DI GOMITO FLEXIBLE HOSE COMPLETE OF ELBOW 90°

CODICE CODE	TUBO TUBE	ATTACCHI CONNECTION	LUNGHEZZA LENGTH	PRESSIONE MAX MAX PRESSURE
0667.JTG1000.00	1"	1" x 1"	600 mm	10 BAR

ACCESSORI PER STAZIONI DI SOLLEVAMENTO (SERIE BOX) ACCESSORIES FOR LIFTING STATIONS (BOX SERIES)



RACCORDO OTTONE
BRASS CONNECTOR

CODICE CODE	DESCRIZIONE DESCRIPTION	DIMENSIONE DIMENSION	ATTACCO CONNECTION
ADF.365.05	A 3 VIE / 3 WAYS	H 72 mm	1" GAS F. F.
ADF.370.05	A 5 VIE / 5 WAYS	H 72 mm	1" GAS F. F.
ADF.375.05	A 5 VIE / 5 WAYS	H 92 mm	1" GAS F. F.



QUADRO ELETTRICO PER MOTORI SOMMERSI 4" MONOFASE
CONTROL BOARD FOR SINGLE PHASE 4 INCH WELLS SUBMERSED MOTOR

CODICE CODE	DESCRIZIONE DESCRIPTION	AMPER	
0726.OPM0500.00	CONTROL BOX CON INTERRUTTORE LUMINOSO ON/OFF + PROTEZIONE AMPEROMETRICA CONTROL BOARD WITH ON/OFF SWITCH + AMPEROMETRIC PROTECTION	HP 0,5 - μ F 20	5
0726.OPM0750.00		HP 0,75 - μ F 25	6
0726.OPM1000.00		HP 1,0 - μ F 35	7
0726.OPM1500.00		HP 1,5 - μ F 40	10
0726.OPM2000.00		HP 2,0 - μ F 50	13
0726.OPM3000.00	INTERRUTTORE ON/OFF NON LUMINOSO ON/OFF SWITCH NOT LIGHTED	HP 3,0 - μ F 80	18



CAVI ELETTRICI PER ELETTROPOMPE SOMMERSE
ELECTRICAL CABLES FOR SUBMERSE ELECTRIC PUMPS

CODICE CODE	TIPO TIPE
0760.SPF.1500.01	4 x 1,5 mm ² - H07RN-F
0760.TRB.2000.01	4 x 2,5 mm ² - H07RN-F
0766.TRB.1005.01	4 x 4 mm ² - H07RN-F
0766.WKR.7005.01	4 x 6 mm ² - H07RN-F
0766.WKR.1000.01	4 x 10 mm ² - H07RN-F



KIT GIUNZIONE CAVI A RESINA COLATA
CUTTING KIT RESISTANT CUTS

CODICE CODE	NUMERO CONDUTTORI	SEZIONE CAVI
KIT.SOMM.GIU.04	4	4 x 1 ÷ 10 mm ²

Kit assemblato su elettropompa
Kit mounted on a pump



KIT GIUNZIONE CAVI TERMORESTRINGENTE
TERMORESTRING CABLE JUNCTION KIT

CODICE CODE	NUMERO CONDUTTORI	SEZIONE CAVI
KIT.SOMM.GIU.01	4	4 x 1 ÷ 2,5 mm ²
KIT.SOMM.GIU.02	4	4 x 4 ÷ 10 mm ²

Kit assemblato su elettropompa
Kit mounted on a pump

ACCESSORI PER STAZIONI DI SOLLEVAMENTO (SERIE BOX) ACCESSORIES FOR LIFTING STATIONS (BOX SERIES)

KIT ALLARME FLASHING SOUND SIGNAL KIT



CODICE CODE	SERIE SERIES	DESCRIZIONE DESCRIPTION
0719.BOX0112.00	LS1-12 VOLT	AVVISATORE ACUSTICO LUMINOSO DI ALLARME ACOUSTIC LUMINOUS WARNING SIGNAL TO INDICATE ALARM VIA REMOTE CONTACT
0719.BOX0124.00	LS1-24 VOLT	
0719.BOX0220.00	LS1-220 VOLT	
0719.BOXBSLO.00	SA/1 c/batterie	

QUADRO ELETTRONICO PER AVVIAMENTO DI UNA POMPA MONOFASE O TRIFASE CON ACQUE PULITE O REFLUE ELECTRONIC FRAMEWORK FOR STARTING A SINGLE-PHASE OR THREE-PUMP WITH PULLEY OR REFLECTIVE WATER



CODICE CODE	POTENZA REGOLABILE		TENSIONE VOLTAGE	CORRENTE NOMINALE A
	kW	HP		
0719.BOX110M.00	da 0.37 a 2.2	da 0.5 a 3	MONOFASE 230V 50 Hz	da 2 a 16
0719.BOX110T.00	da 0.55 a 7.5	da 7.5 a 10	TRIFASE 400V 50 Hz	da 2 a 15

Il quadro è predisposto per il collegamento di tre galleggianti (marcia, arresto e livello di allarme).
The control panel is suitable for connecting three floats (run, stop and alarm level).

QUADRO ELETTRONICO PER AVVIAMENTO DI DUE POMPE MONOFASE O TRIFASE CON ACQUE PULITE O REFLUE ELECTRONIC PANEL FOR STARTING TWO SINGLE PHASE OR THREE PHASE PUMPS WITH CLEANER OR WASTE WATER

CODICE CODE	POTENZA REGOLABILE		TENSIONE VOLTAGE	CORRENTE NOMINALE A
	kW	HP		
0719.BOX210M.00	da 0.37 a 2.2	da 0.5 a 3	MONOFASE 230V 50 Hz	da 2 a 16
0719.BOX210T.00	da 0.55 a 7.5	da 7.5 a 10	TRIFASE 400V 50 Hz	da 2 a 15

Il quadro è predisposto per il collegamento di quattro galleggianti (2 marcia in alternanza, arresto e livello di allarme).
The control panel is suitable for connecting four floats (2 alternating run, stop and alarm level).



GALLEGGIANTE X ACQUE REFLUE FLOATER FOR WASTE WATER

CODICE CODE	DESCRIZIONE DESCRIPTION	MATERIALE MATERIAL
0786.BOX0152.00	LUNGHEZZA CAVO 5 METRI / LENGHT CABLE 5 METERS	H07RN - F
0786.BOX0102.00	LUNGHEZZA CAVO 10 METRI / LENGHT CABLE 10 METERS	H07RN - F



VALVOLA DI RITEGNO A PALLA BALL CHECK VALVE

CODICE CODE	MATERIALE MATERIALS	MISURA SIZE
0663.BOX0102.00	GHISA / CAST IRON	2"
0663.BOX0103.00	GHISA / CAST IRON	3"

ACCESSORI PER STAZIONI DI SOLLEVAMENTO (SERIE BOX) ACCESSORIES FOR LIFTING STATIONS (BOX SERIES)



ALIMENTATORI D'ARIA PER SERBATOI AUTOCLAVI
AIR SUPPLY SYSTEM FOR TANK

CODICE CODE	ATTACCHI CONNECTION	PRESSIONE MAX MAX PRESSURE	CAPACITA' SERBATOIO TANK CAPACITY
AIR 1 - 0,4	1/2	10	100 ÷ 500 lt
AIR 2 - 1,6	3/4	10	750 ÷ 2000 lt

Gli alimentatori garantiscono il mantenimento del cuscino d'aria nell'autoclave.
This items guarantee the keeping of the air in the tank.

Flessibile - Flexible



CONDENSATORI CON CAVI USCENTI
CAPACITOR WITH CABLES

CODICE CODE	CAPACITA' CAPACITY	TENSIONE VOLTAGE
0737.ALK0300.00	8 µF	450 VL
0731.RGL0500.00	10 µF	450 VL
0732.ALK0500.00	12,5 µF	450 VL
0733.TGR0800.00	16 µF	450 VL
0734.TGR0800.00	20 µF	450 VL
0735.SPF1500.00	25 µF	450 VL
0740.TGR1500.00	30 µF	250 VL
0739.RMC2015.00	40 µF	250 VL
0740.TRC2000.00	50 µF	450 VL

TABELLE RESISTENZE CHIMICHE
RESISTANCE CHEMICAL TABLES

TABELLA RESISTENZA CHIMICA

RESISTANCE CHEMICAL TABLE

E EXCELLENT G GOOD P POOR N NOT RECOMMENDED - =NO INFORMATION AVAILABLE B = BOILING C = HOT Ta= ROOM TEMPERATURE		CONCENTRATION	TEMPERATURE °C	AISI 304 18/8/2 CF8M 1.4401-1.4408	AISI 316 18/8/2 CF8M 1.4401-1.4408	CARBON STEEL A 105/A216WCB	CAST IRON	BRASS
Copper Nitrate	5%	+20	E	E	N	N	P	
Copper Nitrate	5%	220	E	E	N	N	—	
Copper Nitrate	50%	C	G	G	N	N	—	
Copper Sulphate	saturated	+20	G	G	N	N	—	
Copper Sulphate		B	G	G	N	N	N	
Copper Sulphate		+20	G	G	N	N	N	
Creosote		C	G	G	G	G	—	
Creosote Oil		Ta	G	G	G	G	E	
Cyclohexane		Ta	E	E	E	E	—	
Dichloroethane		B	G	G	N	N	—	
Diethylamine		Ta	E	E	E	E	—	
Diethyl Ether		+20	E	E	E	G	—	
Distilled Water		Ta	E	E	P	P	E	
Epsom Salt		Ta	G	G	P	P	—	
Ethane		Ta	G	G	G	G	E	
Ethyl Acrylate		Ta	E	E	P	P	—	
Ethyl Alcohol		B	G	G	G	G	E	
Ethyl Acetate		Ta	G	G	G	G	E	
Ethyl Chloride	dry	+20	E	E	E	E	—	
Ethyl Chloride		+20	E	E	E	E	G	
Ethylene Glycol		+20	E	E	E	E	G	
Ethylene Oxide		Ta	G	G	G	G	E	
Fatty Acids		B	G	G	P	P	N	
Ferric Chloride	1%	+20	N	P	N	N	N	
Ferric Chloride	5%	+20	N	N	N	N	N	
Ferric Nitrate		Ta	P	P	N	N	N	
Ferric Nitrate	5%	+20	G	G	N	N	N	
Ferric Sulphate		+20	G	E	N	N	N	
Ferric Sulphate	5%	B	G	G	N	N	N	
Ferrous Chloride		Ta	N	N	N	N	N	
Ferrous Sulphate	saturated	+20	G	G	N	N	N	
Ferrous Sulphate		10%	+20	G	G	N	N	N
Fertilizers		Ta	G	G	G	G	—	
Fish Oil		Ta	E	E	G	G	—	
Fluorine	dry	+20	G	G	N	N	—	
Formaldehyde		Cold	E	E	E	G	P	
Formaldehyde	Hot	P	P	N	N	P		
Formic Acid	5-50%	+20	G	G	N	N	N	
Formic Acid	10-50%	B	N	N	N	N	N	
Formic Acid	100%	+20	P	P	N	N	N	
Formic Acid	100%	B	N	N	N	N	N	
Freon	dry	Ta	E	E	E	E	E	
Freon		wet	Ta	P	P	P	P	E
Fuel Oil		Ta	E	E	G	G	E	
Furfuraldehyde		+20	G	G	G	G	E	
Gallic Acid	5% dry wet	+70	G	G	N	N	—	
Gas Chlorate		+20	N	P	G	G	—	
Gas Chlorate		+100	N	N	N	N	—	
Gaseous Methyl Chloride		+20	G	G	N	N	—	
Gelatine		Ta	E	E	N	N	G	
Glue		Ta	G	G	E	E	—	
Glucose		Ta	G	G	G	G	E	
Glycerol		+20	E	E	E	E	E	
Glycols		Ta	G	G	G	G	—	
Heptane		Ta	E	E	G	G	—	
Hexane		Ta	G	G	G	G	—	
Hexanol		Ta	E	E	E	E	—	
Hydraulic Oil		Ta	E	E	E	E	—	
Hydriodic Acid (iodidrico)	diluted	+20	N	N	N	N	—	
Hydrocarbons		+20	E	E	E	E	E	
Hydrobromic Acid		+20	N	N	N	N	N	
Hydrocyanic Acid		+20	G	G	P	P	—	
Hydrochloric Acid	1% 1% 5%	+20	N	P	N	N	N	
Hydrochloric Acid		B	N	N	N	N	N	
Hydrochloric Acid		+20	N	N	N	N	N	
Hydrochloric Acid		+20	N	N	N	N	N	

E EXCELLENT G GOOD P POOR N NOT RECOMMENDED - =NO INFORMATION AVAILABLE B = BOILING C = HOT Ta= ROOM TEMPERATURE		CONCENTRATION	TEMPERATURE °C	AISI 304 18/8/2 CF8M 1.4401-1.4408	AISI 316 18/8/2 CF8M 1.4401-1.4408	CARBON STEEL A 105/A216WCB	CAST IRON	BRASS
Hydrofluoric Acid	concentrated	+20	N	N	N	N	N	
Hydrofluoric Acid	dry	+20	P	P	P	P	N	
Hydrofluoric Acid	wet	+20	N	N	N	N	N	
Hydrofluoric Acid	cold	+20	N	N	N	N	N	
Hydrogen Gas		Ta	E	E	E	G	—	
Hydrogen Dioxide		+20	E	E	N	N	N	
Hydrogen Dioxide		B	G	G	N	N	N	
Illuminating Gas		Ta	E	E	E	E	—	
Ink	dry	Ta	E	E	N	N	—	
Iodine		+20	N	N	P	N	—	
Iodine	wet	+20	N	N	N	N	—	
Iodoform		+20	E	E	N	N	—	
Isocotane		Ta	E	E	E	E	—	
Isopropyl Ether		Ta	E	E	E	G	—	
Isopropyl Alcohol		Ta	G	G	G	G	—	
Julces		B	G	E	N	N	N	
Ketone		Ta	E	E	E	E	—	
Kerosene		Ta	E	E	G	G	—	
Lactic Acid	1%	B	G	G	N	N	P	
Lactic Acid	5%	+70	G	G	N	N	P	
Lactic Acid	5%	B	N	N	N	N	P	
Lactic Acid	5-10%	+20	G	E	N	N	P	
Lactic Acid	10%	+70	P	G	N	N	P	
Lactic Acid	10%	B	N	P	N	N	P	
Lactic Acid	concentrated	B	N	N	N	N	P	
Latex		+20	E	E	N	N	—	
Latex Emulsions		Ta	E	E	G	G	—	
Lead Acetate		+20	G	G	N	N	—	
Lead Acetate		Ta	G	G	N	N	—	
Lemon Juice		Ta	G	G	N	N	N	
Linoleic Acid		Ta	E	E	G	G	—	
Linseed Oil		Ta	G	G	E	E	G	
Liquefied Gas (LPG)		Ta	G	G	G	G	—	
Lithium		+150	E	E	G	G	—	
Lubricating Oil		Ta	E	E	E	E	—	
Lye		B	G	G	N	N	N	
Lysol		+20	P	P	N	N	—	
Magnesium Chloride	5%	+20	G	G	N	N	N	
Magnesium Chloride	5%	C	N	N	N	N	N	
Magnesium Chloride	10-30%	+20	P	G	N	N	N	
Magnesium Chloride	saturated	+20	P	G	N	N	N	
Magnesium Chloride	5%	+20	G	G	N	N	N	
Magnesium Disulphate		Ta	E	E	G	G	—	
Magnesium Hydroxide		C	E	E	G	G	G	
Magnesium Oxide		+20	G	G	G	G	—	
Magnesium Sulphate		+20	G	G	G	G	P	
Magnesium Sulphate		+20	G	G	G	G	P	
Maleic Acid		Ta	G	G	G	G	—	
Malic Acid		C	G	G	N	N	—	
Mercury		+150	P	P	G	G	N	
Mercury		+500	N	N	N	N	N	
Mercury Bichloride	2%	+20	N	N	N	N	N	
Mercury Cyanide		+20	G	G	N	N	N	
Mercury Cyanide		+20	G	G	N	N	—	
Mercuric Chloride		Ta	N	P	N	N	—	
Methane		Ta	G	G	G	G	E	
Methyl Acetate		Ta	E	E	E	G	—	
Methyl Alcohol		B	P	G	G	G	E	
Methylacetone		Ta	E	E	G	G	—	
Methylamine		Ta	E	E	G	G	—	
Methyl Chloride		+20	G	G	N	N	G	
Methylene Chloride		Ta	E	E	G	G	G	
Methyl Formate		Ta	G	G	P	P	—	
Milk		+20	E	E	N	N	G	
Mineral Naphtha		+20	G	G	G	G	G	
Mineral Oil		Ta	E	E	G	G	E	

TABELLA RESISTENZA CHIMICA

RESISTANCE CHEMICAL TABLE

E EXCELLENT G GOOD P POOR N NOT RECOMMENDED - =NO INFORMATION AVAILABLE B = BOILING C = HOT Ta= ROOM TEMPERATURE	CONCENTRATION	TEMPERATURE °C						CONCENTRATION	TEMPERATURE °C					
			AISI 304 18/8/2 CF8M 1.4401-1.4408	AISI 316 18/8/2 CF8M 1.4401-1.4408	CARBON STEEL A 105/A216WCB	CAST IRON	BRASS			AISI 304 18/8/2 CF8M 1.4401-1.4408	AISI 316 18/8/2 CF8M 1.4401-1.4408	CARBON STEEL A 105/A216WCB	CAST IRON	BRASS
Sodium Metaphosphate	cold	Ta	E	E	G	G	N	+20	F	F	P	P	F	
Sodium Metasilicate		C	E	E	P	P	-		C	G	G	N	N	E
Sodium Metasilicate	+20	Ta	E	E	G	G	-	Ta	G	G	P	P	-	
Sodium Nitrate		Ta	G	G	G	G	-	Ta	G	G	N	N	-	
Sodium Nitrate	Ta	Ta	G	G	G	G	P	Ta	G	G	G	G	-	
Sodium Perborate		Ta	G	G	G	G	-	Ta	G	G	P	P	-	
Sodium Peroxide	Ta	Ta	G	G	P	P	P	Ta	E	E	E	E	-	
Sodium Phosphate		Ta	G	G	P	P	-	Ta	E	E	E	E	-	
Sodium Silicate	Ta	Ta	G	G	G	G	G	Ta	E	E	G	G	-	
Sodium Silicate		C	G	G	P	P	G	Ta	E	E	E	E	-	
Sodium Silicate	Ta	Ta	G	G	G	G	-	Ta	E	E	E	E	-	
Sodium Sulphate		saturated	+20	P	G	G	G	G	Ta	E	E	E	E	-
Sodium Sulphate	10%	+20	P	G	G	G	G	Ta	E	E	E	E	-	
Sodium Sulphite		+65	P	G	G	G	G	Ta	E	E	E	E	-	
Sodium Sulphite	10%	B	P	G	N	N	G	Ta	E	E	E	E	-	
Sodium Sulphite	saturated	+20	G	G	G	G	G	Ta	E	E	E	E	-	
Sodium Trisulphate	20%	+20	G	G	N	N	-	Ta	E	E	E	E	-	
Sodium Thiosulphate		Ta	E	E	G	G	-	Ta	E	E	E	E	-	
Soft Water	Ta	Ta	E	E	P	P	N	Ta	E	E	E	E	-	
Solvent		Ta	E	E	G	G	E	Ta	E	E	E	E	-	
Spirit Vinegar	+20	Ta	E	E	N	N	-	Ta	E	E	N	N	-	
Starci		Ta	G	G	P	P	-	Ta	G	G	P	P	-	
Stannic Chloride	5%	+20	N	P	N	N	-	Ta	G	G	P	P	-	
Stannic Chloride	5%	B	N	N	N	N	-	Ta	G	G	P	P	-	
Stannic Chloride	5%	+20	N	P	N	N	-	Ta	G	G	P	P	-	
Stannous Chloride	saturated	+20	N	P	N	N	-	Ta	G	G	P	P	-	
Stearic Acid	+20	Ta	G	E	P	P	P	Ta	G	E	P	P	P	
Strontium Nitrate		Ta	E	E	N	N	-	Ta	E	E	E	E	-	
Styrene	Ta	Ta	E	E	E	E	-	Ta	E	E	E	E	-	
Suds (Stearate)		Ta	E	E	E	G	-	Ta	E	E	E	E	-	
Sugary Juices in general	+70	Ta	G	G	N	N	N	Ta	E	E	E	E	-	
S Sulphur		dry and liquefied	+230	G	G	G	G	N	Ta	E	E	E	E	-
S Sulphur	wet and liquefied	+230	P	G	N	N	N	Ta	E	E	E	E	-	
Sulphuric Anhydride	dry	Ta	E	E	G	G	G	Ta	E	E	E	E	-	
Sulphuric Acid	dry	+20	E	E	E	E	-	Ta	E	E	E	E	-	
Sulphuric Acid	wet	+20	P	G	P	P	-	Ta	E	E	E	E	-	
Sulphuric Acid	5%	+20	P	G	N	N	N	Ta	E	E	E	E	-	
Sulphuric Acid	5%	B	N	P	N	N	N	Ta	E	E	E	E	-	
Sulphuric Acid	10%	+20	N	P	N	N	N	Ta	E	E	E	E	-	
Sulphuric Acid	10%	B	N	N	N	N	N	Ta	E	E	E	E	-	
Sulphuric Acid	50%	+20	N	N	N	N	N	Ta	E	E	E	E	-	
Sulphuric Acid	50%	B	N	N	N	N	N	Ta	E	E	E	E	-	
Sulphuric Acid	concentrated	+20	G	G	G	G	N	Ta	E	E	E	E	-	
Sulphuric Acid	concentrated	B	N	N	N	N	N	Ta	E	E	E	E	-	
Sulphuric Acid	fuming	+20	P	G	P	P	N	Ta	E	E	E	E	-	
Sulphur Chloride	Ta	Ta	P	G	N	N	-	Ta	E	E	E	E	-	
Sulphur Dioxide		dry	+250	G	G	G	G	E	Ta	E	E	E	E	-
Sulphur Dioxide	dry	+230	G	G	G	G	N	Ta	E	E	E	E	-	
Sulphur Dioxide	wet	+20	P	G	N	N	N	Ta	E	E	E	E	-	
Sulphurous Acid	saturated	+20	N	G	N	N	P	Ta	E	E	E	E	-	
Syngas	Ta	Ta	G	G	G	G	-	Ta	E	E	E	E	-	
Tannic Acid		+20	G	G	N	N	G	Ta	E	E	E	E	-	
Tar	Ta	Ta	E	E	E	E	G	Ta	E	E	E	E	-	
Tartaric Acid		10%	+20	E	E	N	N	P	Ta	E	E	E	E	-
Tartaric ACid	10%	C	P	G	N	N	P	Ta	E	E	E	E	-	
Tetraethyl Lead	Ta	Ta	G	G	P	P	-	Ta	E	E	E	E	-	
Titanium Tetrachloride		wet	+20	N	N	N	N	-	Ta	E	E	E	E	-
Tomato Juice	Ta	Ta	E	E	P	P	N	Ta	E	E	E	E	-	
Toluene		Ta	E	E	E	E	E	Ta	E	E	E	E	-	
Tributyl Phosphate	Ta	Ta	E	E	E	E	-	Ta	E	E	E	E	-	
Trichloroethylene		dry	Ta	G	G	G	P	E	Ta	E	E	E	E	-
Trichloroacetic Acid	+20	N	N	N	N	P	Ta	E	E	E	E	-		
Tung Oil	Ta	Ta	G	G	P	P	-	Ta	E	E	E	E	-	
Turpentine		+20	E	E	E	E	G	Ta	E	E	E	E	-	
Urea	Ta	Ta	G	G	P	P	-	Ta	E	E	E	E	-	
Uric Acid		concentrated	+20	G	G	N	N	-	Ta	E	E	E	E	-

TABELLA RESISTENZA CHIMICA RESISTANCE CHEMICAL TABLE

	E EXCELLENT G GOOD P POOR N NOT RECOMMENDED - =NO INFORMATION AVAILABLE	E EXCELLENT G GOOD P POOR N NOT RECOMMENDED - =NO INFORMATION AVAILABLE	E EXCELLENT G GOOD P POOR N NOT RECOMMENDED - =NO INFORMATION AVAILABLE	E EXCELLENT G GOOD P POOR N NOT RECOMMENDED - =NO INFORMATION AVAILABLE	E EXCELLENT G GOOD P POOR N NOT RECOMMENDED - =NO INFORMATION AVAILABLE
Acetaldehyde	G				
Acetal		E		E	E
Acetammide		E		E	E
Acetate Solvent		E	G	N	E
Acetilene	E	E	G	G	E
Acetic Acid 10-20%	N	E	E	E	E
Acetic Acid 50%	N	E	E	E	E
Acetic Acid 80%	N	E	G	G	E
Acetic Anhydride	N		N	N	E
Acetylene Chloride			N	N	E
Acetoacetato di Etile			N	N	E
Acetofenone			N	N	E
Acetone	E	E	N	N	E
Acetone 50% water			N		E
Acetonitrile					E
Acid Chloric 20%			N	N	E
Acido Laisileico			G	G	E
Acido Cresilico	N		N	N	E
Acrylonitrile			N	N	E
Adipic Acid			N	N	E
Air		E	E	E	E
Alumed Chrome		E	G	G	E
Alumed Potassium		E	G	G	E
Alumed Potassium Sulphate		E	G	G	E
Alumina		E	E	G	E
Aluminium Chloride	E	E	G	G	E
Aluminium Fluoride		E	G	G	E
Aluminium Hydroxide	E	E	G	G	E
Aluminium Nitrate		E	G	G	E
Aluminium Sulphate	E	E	G	G	E
Alum. (Al. Potassium Sulphate)	E	E	E		E
Amyl Alcohol	E	E			E
Amyl Acetate	E	N	N	N	E
Ammonium Acetate		E	N		E
Ammonia (Anhydrous)		E	G	N	E
Ammonia (Gas)		E	G	N	E
Ammonium Chloride	P	E	G	G	E
Ammonium Sulphate	E	E	G	G	E
Ammonium Sulphate 50°C		E	E	N	E
Ammonium Sulphide		E	E		E
Ammonium Hydroxide		E	G	G	E
Ammonium Fluoride 25%		E	G	G	E
Ammonium Phosphate		E	G	G	E
Ammonium Metaphosphate			G	G	E
Ammonium Nitrate		E	G	N	E
Ammonium Oxalate	E	E			E
Ammonium Bicarbonate	P	E	E		E
Ammonium Bifluoride		E	E		E
Ammonium Carbonate	P	E	G	G	E
Amyl Chloride 77°C			N	E	
Anhydrous Formic Acid	N		N	G	E
Aniline	E	E	N	E	E
Aqua Regia			N	E	E
Arsenic Acid			G	G	E
Artificial Gas			G	G	E
Asphalt	E		N	E	E
Barium Carbonate		E			E
Barium Chloride		E	E	G	E
Barium Hydroxide		E	E	G	E
Barium Nitrate		E	E	G	E
Barium Sulphate		E	G	G	E
Barium Sulphide			G	G	E
Beer			N	N	E
Benzaldehyde			N	N	E
Benzene, Benzol			N	N	E
Benzoic Acid			E	G	E
Benzyl Alcohol			N	N	E
Benzyl Chloride			N	N	E
Black Liquor			E	G	E
Borax		E	E	G	E
Boric Acid		E	E	G	E
Brine			G		E
Bromine Water					E
Buty Acetate					E
Buty Alcohol		E	E	N	E
Butyric Acid		E	E	N	E
Buty Chloride					E
Buty Phenol					E
Buty Prthtate			N		E
Butter			E		E
Butadiene		E	E	E	E
Butane		E	E	N	E
Butylene		E	E	N	E
Calcium Bisulphite		E	E	G	E
Calcium Bicarbonate		E	E	G	E
Calcium Carbonate		E	E	G	E
Calcium Chlorate		E	E	G	E
Calcium Chloride		E	E	G	E
Calcium Disulphate					E
Calcium Fluoride					E
Calcium Hydroxide		E	E	G	E
Calcium Hipochlorite		E	E	N	E
Calcium Nitrate		E	E	G	E
Calcium Oxide 20°C					E
Calcium Sulphate		E	E		E
Cane Sugar Liquor			E	G	E
Carbolic Acid (phenol)			N	N	E
Carbonic Acid	N		G	G	E
Carbon Bisulphide			N	G	E
Carbon Dioxide					E
Carbon Monoxide			E	G	E
Castor Oil		E	E	G	E
Cauatic Soda			E	P	E
Cellulose Acetate			E	N	E
Cellulose			E	G	E
Cement					E
Cereal Syrup (Glucose)				G	E
Chloroacetic Acid				N	E
Chloroform		E		G	E
Chlorosulfonic Acid					E
Chlorine Dioxide				N	E
Chlorine Water				N	E

TABELLA RESISTENZA CHIMICA

RESISTANCE CHEMICAL TABLE

	DELTRIN	EPDM	NBR	VITON	PTFE		DELTRIN	EPDM	NBR	VITON	PTFE
E EXCELLENT						E EXCELLENT					
G GOOD						G GOOD					
P POOR						P POOR					
N NOT RECOMMENDED						N NOT RECOMMENDED					
--NO INFORMATION AVAILABLE						--NO INFORMATION AVAILABLE					
Chlorine Water	—	—	N	—	E	Ethyl Glycol	—	E	E	E	E
Chlorobenzene	E	N	N	G	E	Ethylene Bromide	—	—	N	—	E
Chromic Acid	N	—	G	E	E	Ethylene Chloride	—	—	N	E	E
Chromic Anhydride	—	—	G	E	E	Ethylene Diamine	—	—	E	E	E
Chrome Potassium Sulphate	—	—	G	—	E	Ethylene Glycol	—	E	G	E	E
Citric Acid	—	E	G	G	E	Ethylene Oxide	—	—	N	N	E
Coconut Oil	E	—	G	E	E	Epichlorohydrin	—	—	N	N	E
Coffee	—	E	N	E	E	Fats	—	N	E	—	E
Coke-oven Gas	—	E	N	G	E	Fatty Acids	—	—	G	G	E
Copper Acetate	—	—	—	N	E	Ferric Chloride	E	E	G	G	E
Copper Chloride	E	E	G	G	E	Ferric Nitrate 10-50%	—	E	G	G	E
Copper Nitrate	E	—	G	G	E	Ferric Sulphate	E	E	G	G	E
Copper Sulphate	E	E	G	G	E	Feerous Chloride	E	E	G	—	E
Corn Oil	E	—	N	—	E	Ferrous Sulphate	E	E	G	G	E
Cotton seeds Oil	—	—	G	E	E	Fluorinated Hydrogen	—	—	G	G	E
Creosote	—	N	P	E	E	Fluorine Gas	—	—	N	N	E
Cresol	—	—	N	N	E	Fluorosilicic Acid	—	E	P	—	—
Cromil Chloride	—	—	—	—	E	Formaldehyde 35-50%	E	E	N	N	E
Crotonaldehyde	—	—	—	—	E	Formic Acid 10-85%	N	E	N	G	E
Crude Oil	—	—	G	E	E	Freon F 11-12	—	—	G	G	—
Cyanoacetic Acid	—	—	—	—	E	Freon F 22	—	—	N	N	—
Cyanogen Gas	—	E	—	—	E	Fuel Oil	E	N	G	E	E
Cyclohexane	—	N	G	G	E	Fuel for aircrafts (JP4 or JP5)	—	N	G	E	E
Demineralized Water	—	E	G	G	E	Furfural	—	—	N	N	E
Detergents	—	E	G	G	E	Furfuraldehyde	E	—	N	N	E
Dextrite	—	—	N	N	E	Gallic Acid	E	E	—	G	E
Dextrose	—	—	G	G	E	Galvanizing Solution	—	E	G	G	E
Diacetone	—	E	N	N	E	Gaseous Bromine	G	N	N	—	E
Diacetone Alcohol	—	—	N	—	E	Gaseous Oxygen	E	—	N	G	E
Dibutylphthalate	—	—	—	G	E	Gas Oil	—	—	G	G	E
Dichloroethane	—	—	N	E	E	Gelatine	E	—	G	G	E
Dichlorobenzene max 40°C	—	—	—	G	E	Glucose	E	—	G	G	E
Dichloroethane	—	—	N	G	E	Glue	—	E	P	—	E
Dichloroethylene	—	—	N	G	E	Glycerol	P	—	G	E	E
Diethyl Ether	—	—	N	N	E	Glycols 60°C	—	—	E	E	E
Diethyl Ether 40°C	—	—	G	N	E	Glycocic Acid	—	E	—	—	E
Diethylcellosolve	—	—	—	—	E	Green Liquor	—	E	G	—	E
Diethylamine max 40°C	—	—	N	—	E	Helium	—	G	G	—	E
Dimethyl	—	—	—	N	E	Heptane	—	E	G	E	E
Dimethylphthalate	—	—	N	E	E	Hexane	—	N	G	E	E
Dimethyl Ether	—	—	—	—	E	Hexanol	—	—	G	E	E
Dioxan	—	N	N	N	E	Hydraulic Fluid	—	—	G	E	E
Diphenil (Dowtherms)	—	—	N	E	E	Hydrobromic Acid	—	—	N	G	E
Disodium Phosphate 20°C	—	—	N	G	E	Hydrocyanic Acid	—	E	G	G	E
Distiller Water	E	E	G	G	E	Hydrochloric Acid max 50%	—	E	—	G	E
Dry Sulphur Dioxide	N	—	N	N	E	Hydrofluoric Acid max 70%	—	—	N	E	—
Drilling Sludge	—	N	E	—	E	Hydrofluoric Acid 100%	—	—	N	—	—
Drilling Sludge	—	N	E	—	E	Hydrogen Dioxide	E	E	N	E	E
Dry Sulphurized Hydrogen	—	E	—	N	E	Hydrogen Chloride	—	—	—	—	E
Dry Sulphurized Hydrogen	—	E	—	N	E	Hydrogen	—	E	G	G	—
Dyes	—	N	N	—	E	Hydrogen Sulphide	—	—	N	N	E
Dyes	—	N	N	—	E	Hydroquinone	—	E	N	G	E
Ethyl Acetate	E	N	N	N	E	Ink	—	E	—	—	—
Ethyl Acrylate	—	E	G	G	E	Industrial Oils	—	—	—	—	E
Ethyl Alcohol	E	E	P	E	E	Iodoform	E	—	N	E	E
Ethyl Chloride	E	—	G	G	E	Isobutyl-Methyl-Ketone	—	—	N	N	E











TABELLA RESISTENZA CHIMICA RESISTANCE CHEMICAL TABLE

	-NO INFORMATION AVAILABLE					-NO INFORMATION AVAILABLE				
	E G P N	EXCELLENT GOOD POOR NOT RECOMMENDED	E G P N	EXCELLENT GOOD POOR NOT RECOMMENDED	E G P N	EXCELLENT GOOD POOR NOT RECOMMENDED	E G P N	EXCELLENT GOOD POOR NOT RECOMMENDED	E G P N	EXCELLENT GOOD POOR NOT RECOMMENDED
Isooctane	E		E		E		E		E	
Isopropyl Alcohol	E		E		E		E		E	
Isopropyl Ether	E		E		E		E		E	
Juices	E		G		E		E		E	
Kerosene	-		G		E		E		E	
Lactic Acid	-	N	-		E		E		E	
Lard Oil	-		-		E		E		E	
Lead Acetate	E		-		E		E		E	
Lead Chloride max 20°C	-		-		E		E		E	
Lead Sulphate	-		-		E		E		E	
Leaded Petrol	E		-		E		E		E	
Lemon Oil	-		G		E		E		E	
Lime	-		G		E		E		E	
Lime Sulphur	-		E		E		E		E	
Linseed Oil	-		E		E		E		E	
Liquid Chlorine	-		-		E		E		E	
Liquid Soap	-		E		E		E		E	
Lubricating Oil	-		E		E		E		E	
Maleic Acid	E		E		E		E		E	
Maleic Acid	E		E		E		E		E	
Malic Acid	E		E		E		E		E	
Manganese Chloride max 20°C	-		-		E		E		E	
Magnesium Carbonate	-		-		E		E		E	
Magnesium Chloride	E		E		E		E		E	
Magnesium Hydroxide	E		E		E		E		E	
Magnesium Nitrate	E		E		E		E		E	
Magnesium Oxide	-		G		E		E		E	
Machine Oil	-		-		E		E		E	
Magnesium Sulphate	E		E		E		E		E	
Methane	E		E		E		E		E	
Methanol	-		E		E		E		E	
Methyl Acetate	-		E		E		E		E	
Methyl Alcohol	-		P		E		E		E	
Methyl Bromine	E		E		E		E		E	
Methyl Chloride	-		-		E		E		E	
Methyl Methacrylate	-		-		E		E		E	
Methylene Chloride	-		N		E		E		E	
Methylacetone	-		N		E		E		E	
Methylcellosolve	-		G		E		E		E	
Methyl-Ethyl-Ketone	-		P		E		E		E	
Mercury	-		-		E		E		E	
Mercuric Chloride	E		-		E		E		E	
Mercuric Nitrate	-		E		E		E		E	
Milk	E		-		E		E		E	
Mineral Oil	E		G		E		E		E	
Mineral Water	E		G		E		E		E	
Mineral Naphtha (Combustible Oil)	E		E		E		E		E	
Mixed Acids (°T max 32°C)	E		N		E		E		E	
Molasses Monoclorobenzene 20°C	-		E		E		E		E	
Motor Oil	-		-		E		E		E	
n Butyl Mercaptan	-		G		E		E		E	
Naphthalene	E		-		E		E		E	
Natural Gas	E		E		E		E		E	
Nickel Ammonium Sulphate	-		G		E		E		E	
Nickel Chloride	E		-		E		E		E	
Nickel Nitrate	E		-		E		E		E	
Nickel Salt	-		-		E		E		E	
Nickel Sulphate	E		E		E		E		E	
Nicotine	-		-		E		E		E	
Nicotinic Acid	-		-		E		E		E	
Nitric Acid	-		N		E		E		E	
Nitrobenzene 25°C	-		N		E		E		E	
Nitrobenzene over 25°C	-		G		E		E		E	
Nitrogen	E		-		E		E		E	
Nitromethane	-		G		E		E		E	
Nitrous Oxide 40°C	-		-		E		E		E	
Oleum	-		N		E		E		E	
Oleic Acid	E		-		E		E		E	
Oli Vegetali	-		E		E		E		E	
Olive Oil	-		G		E		E		E	
Oxalic Acid	-		P		E		E		E	
Oxygen	E		E		E		E		E	
Ozone	-		-		E		E		E	
Paint Solvents	-		-		E		E		E	
Palmitic Acid	E		-		E		E		E	
Paraffin Wax	E		-		E		E		E	
Perchloric Acid	-		-		E		E		E	
Perchloroethylene	-		-		E		E		E	
Persolfato di Ammonio	-		N		E		E		E	
Petrol Oils (acid or refined oils)	-		E		E		E		E	
Petrolum (Vaseline)	-		-		E		E		E	
Phenil Chloride (Chlorobenzene)	-		-		E		E		E	
Phenylhydrazine	-		-		E		E		E	
Phenol (Carbolic Acid)	-		N		E		E		E	
Phosphate 50°C	-		-		E		E		E	
Phosphoric Acid 10%	-		N		E		E		E	
Phosphoric Acid 25/50%	-		N		E		E		E	
Phosphoric Acid 50/80%	-		N		E		E		E	
Phosphorous Oxichloride	-		E		E		E		E	
Phosphorous Pentoxide 20°C	-		-		E		E		E	
Phthalic Acid	-		-		E		E		E	
Phthalic Anhydride	E		-		E		E		E	
Picric Acid	-		E		E		E		E	
Pickling solution	-		-		E		E		E	
Polyvinyl Acetate	-		N		E		E		E	
Potassium Bicarbonate	-		-		E		E		E	
Potassium Bichromate (30%)	-		G		E		E		E	
Potassium Carbonate	E		-		E		E		E	
Potassium Chlorate 50%	-		G		E		E		E	
Potassium Chloride	-		G		E		E		E	
Potassium Chromate 30%	E		E		E		E		E	
Potassium Cyanide 30%	-		E		E		E		E	
Potassium Ferricyanide 30%	-		E		E		E		E	
Potassium Fluoride	-		-		E		E		E	
Potassium Hydroxide	-		G		E		E		E	
Potassium Hydroxide 5-30%	-		G		E		E		E	
Potassium Hydroxide 50-90%	-		G		E		E		E	
Potassium Hypochlorite 30°C	-		G		E		E		E	
Potassium Hypochlorite 90°C	-		N		E		E		E	

TABELLA RESISTENZA CHIMICA

RESISTANCE CHEMICAL TABLE

	<table border="0"> <tr> <td style="background-color: #e0f0e0;">E</td><td>EXCELLENT</td> </tr> <tr> <td style="background-color: #e0f0e0;">G</td><td>GOOD</td> </tr> <tr> <td style="background-color: #fff9c4;">P</td><td>POOR</td> </tr> <tr> <td style="background-color: #ffe0b2;">N</td><td>NOT RECOMMENDED</td> </tr> <tr> <td colspan="2">--=NO INFORMATION AVAILABLE</td> </tr> </table>					E	EXCELLENT	G	GOOD	P	POOR	N	NOT RECOMMENDED	--=NO INFORMATION AVAILABLE		DELRIIN	EPDM	NBR	VITON	PTFE		<table border="0"> <tr> <td style="background-color: #e0f0e0;">E</td><td>EXCELLENT</td> </tr> <tr> <td style="background-color: #e0f0e0;">G</td><td>GOOD</td> </tr> <tr> <td style="background-color: #fff9c4;">P</td><td>POOR</td> </tr> <tr> <td style="background-color: #ffe0b2;">N</td><td>NOT RECOMMENDED</td> </tr> <tr> <td colspan="2">--=NO INFORMATION AVAILABLE</td> </tr> </table>					E	EXCELLENT	G	GOOD	P	POOR	N	NOT RECOMMENDED	--=NO INFORMATION AVAILABLE		DELRIIN	EPDM	NBR	VITON	PTFE
	E	EXCELLENT																																							
G	GOOD																																								
P	POOR																																								
N	NOT RECOMMENDED																																								
--=NO INFORMATION AVAILABLE																																									
E	EXCELLENT																																								
G	GOOD																																								
P	POOR																																								
N	NOT RECOMMENDED																																								
--=NO INFORMATION AVAILABLE																																									
DELRIIN	EPDM	NBR	VITON	PTFE																																					
Potassium Iodide 70%	E	F	—	—	E	Suds	—	E	G	—	E																														
Potassium Nitrate 80%	—	E	G	G	E	Sugarbeet Liquor	—	—	—	G	E																														
Potassium Nitrate 1-5%	—	E	G	G	E	Sulphuric Acid 10-50%	P	E	P	E	E																														
Potassium Oxalate 20%	—	—	—	—	E	Sulphuric Acid 60-70%	P	E	N	E	E																														
Potassium Permanganate	—	E	N	P	E	Sulphuric Acid 80-100%	N	—	N	E	E																														
Potassium Phosphate	—	—	E	E	E	Sulphurous Acid	P	—	N	G	E																														
Potassium Sulphate 10%	E	E	G	G	E	Sulphamic Acid	—	E	—	—	E																														
Potassium Sulphite	—	G	P	—	E	Sulphur 20°C	—	—	N	N	E																														
Potassium Sulphite	—	—	—	N	E	Sulphur Chloride	—	E	G	—	E																														
Propane	E	E	G	E	E	Swimming pool Water	—	—	N	P	E																														
Propanol	—	—	G	G	E	Tannic Acid	E	—	N	P	E																														
Propylene Oxide	—	—	N	—	E	Tar	E	N	N	G	E																														
propylene Glycol	—	—	G	G	E	Tartaric Acid	E	—	G	G	E																														
Pyridine	—	—	N	N	E	Tetraphosphoric Acid	—	—	—	—	E																														
Pyrogallic Acid	E	—	P	P	E	Tetrachydrofuran	—	—	N	N	E																														
Resins	—	—	—	G	E	Tetraethyl Lead	—	—	N	G	E																														
Salicylic Acid	E	—	N	G	E	Thionyl Chloride	—	—	N	N	E																														
Salt Water	—	E	G	G	E	Toluene	E	N	N	G	E																														
Sea Water	E	E	G	G	E	Tomato Juice	—	—	G	G	E																														
Sewage	—	G	G	G	E	Trichloroacetic Acid	—	—	N	G	E																														
Sewage	—	—	G	G	E	Trisodium Phosphate	—	—	G	G	E																														
Silver Nitrate	E	E	G	G	E	Tributyl Phosphate 30°C	—	—	N	N	E																														
Silicone Oil	—	—	G	G	E	Trichloroethylene	—	—	N	E	E																														
Sodium Acetate	E	E	—	N	E	Transformer Oil	—	—	G	G	E																														
Sodium Bicarbonate	E	E	G	G	E	Turpentine	E	N	G	G	E																														
Sodium Bichromate	—	—	—	G	E	Unleaded Petrol	E	—	G	G	E																														
Sodium Bisulphite	E	E	G	G	E	Urea	—	—	N	E	E																														
Sodium Borate	E	—	G	G	E	Various Esters	—	—	—	—	E																														
Sodium Bromide	—	—	E	E	E	Various Ethers 40°C	—	—	G	N	E																														
Sodium Carbonate	E	—	G	G	E	Various Soaps	—	—	G	G	E																														
Sodium Chlorate	—	E	G	G	E	Various Ketones	—	—	N	N	E																														
Sodium Chlorite	—	—	—	—	E	Vaseline	—	—	P	P	E																														
Sodium Chloride	E	E	G	G	E	Vegetable Oil	—	—	G	E	E																														
Sodium Disulphate	—	—	G	G	E	Vinyl Acetate	—	—	N	G	E																														
Sodium Fluoride	—	E	—	—	—	Wet Chlorine Gas	—	E	N	G	E																														
Sodium Hydroxide (Caustic Soda)	—	E	P	—	E	Wet Sulphurized hydrogen	—	E	N	E	E																														
Sodium Hypochlorite	E	E	N	G	E	Wet Sulphur Dioxide	E	E	G	N	E																														
Sodium Hypochlorite	—	E	G	G	E	White Liquor	—	E	N	G	E																														
Sodium Metaphosphate	—	—	G	G	E	Wine	—	—	G	G	E																														
Sodium Nitrate	E	E	P	N	E	Xylene, Xylol	—	—	N	G	E																														
Sodium Nitrite	—	—	—	—	E	Zinc Chloride	E	E	G	G	E																														
Sodium Perborate 10%	E	—	G	G	E	Zinc Nitrate	—	—	—	G	E																														
Sodium Peroxide 10%	—	E	G	G	E	Zinc Sulphate 30%	—	E	G	G	E																														
Sodium Phosphate	—	—	G	G	E																																				
Sodium Silicate	E	E	G	G	E																																				
Sodium Sulphate	E	E	G	G	E																																				
Sodium Sulphite 10%	—	E	G	G	E																																				
Sodium Sulphide 50%	E	E	G	G	E																																				
Sodium Thiosulphate	E	E	G	G	E																																				
Soft Water	E	E	E	—	—																																				
Spirit Vinegar	N	—	N	G	E																																				
Stannic Chloride	—	E	G	G	E																																				
Stannous Chloride	—	E	G	G	E																																				
Starci	—	G	G	—	E																																				
Steam 130°C	N	E	N	N	E																																				
Stearic Acid	E	—	G	—	E																																				

-  **POMPE SOMMERSIBILI INOX - SUBMERSIBLE INOX PUMPS** 
-  **POMPE SOMMERSIBILI IN GHISA - SUBMERSIBLE PUMPS IN CAST IRON** 
-  **POMPE SOMMERSE - SUBMERSIBLE PUMPS** 
-  **POMPE SOMMERSIBILI IN PLASTICA - PLASTIC SUBMERSIBLE PUMPS** 
-  **POMPE DI SUPERFICIE - SURFACE PUMPS** 
-  **GRUPPI DI PRESSURIZZAZIONE - PRESSURE SYSTEM** 
-  **MOTOPOMPE - GASOLINE WATER PUMPS** 
-  **POMPE A MANO - HANDS PUMPS** 



ARVEN S.r.l.
Via Artigiani n°10
25030 Maclodio - Brescia Italy
Tel. +39.030.9973973
Fax +39.030.9973975
e-mail: info@arven.it
www.arven.it